

Model 875PH
Intelligent Electrochemical Analyzer for
pH, ORP, or Ion Selective Electrode (ISE) Measurement

PANEL MOUNTED
ANALYZER



FIELD MOUNTED ANALYZER



This microprocessor-based, line-powered intelligent analyzer, when used with compatible Foxboro DolpHin™ PH10 and ORP10, 871A, 871PH, or EP460 Series pH and ORP Sensors, provides high accuracy measurement of pH, ORP, or ISE. Functions include measurement display, dual analog outputs, and dual relay contacts. A human interface guides the user through intuitive, menu-driven configuration, calibration, status, and troubleshooting procedures.

FEATURES

- ▶ Easy to use.
- ▶ Optional HART Communication Protocol.
- ▶ Auto Buffer Recognition for flawless pH calibrations.
- ▶ Quick and informative status.
- ▶ Dual Alarms and Dual 4 to 20 mA Outputs.
- ▶ NEMA 4X and IEC IP65 protection for field mounted analyzer, and for front surface of panel mounted analyzer.
- ▶ Single unit for either pH, ORP, or ISE.
- ▶ Compatible with a wide range of sensors.
- ▶ History log for up to 100 events.
- ▶ On-Line sensor and analyzer diagnostics communicate real-time measurement faults.
- ▶ Remote auto-service for sensor cleaning and calibration.
- ▶ Secure data and calibrations.
- ▶ Complies with EMC Directive 89-336-EEC.

Equipment should be installed, operated, serviced, and maintained only by qualified personnel. No responsibility is assumed by Schneider Electric for any consequences arising from the use of this material.

EASY TO USE

The Model 875PH Electrochemical Analyzer provides fast and simple installation, configuration, and operation. Input and output wiring is easily accessible. On the field-mounted version, all wiring terminals are accessible through a removable, front-facing cover. On the panel-mounted version, wiring terminals are directly accessible from the rear of the analyzer without removing any covers.

A large, backlit Liquid Crystal Display (LCD) with intuitive menu navigation and on-screen help makes configuration easy and less prone to error. Users have a choice of either **basic** or **advanced** configuration, depending on their needs. **Basic** configuration provides access to only the most commonly changed parameters, greatly simplifying the procedure. **Advanced** configuration, which is protected by a different passcode than **basic**, allows for complete configuration by authorized personnel. Prior to accepting a new configuration, the analyzer performs complete parameter dependency checking, and informs the user of any conflicting or offending parameters. The analyzer then brings the user to the parameter(s) in question, and prompts the user to review the selection(s) that must be altered.

Calibration routines are also intuitive and menu-driven. Users can choose electronic or solution calibration routines, depending on user preference and measurement mode (pH, ORP, or ISE).

SENSOR AND ANALYZER DIAGNOSTICS

When used with applicable Foxboro DolpHin PH10 and ORP10, 871PH, 871A, or EP460 Series pH and ORP Sensors, the analyzer delivers a multitude of sensor diagnostics. These include:

- ▶ Broken Glass Electrode
- ▶ Aging Glass Electrode
- ▶ Liquid Leakage into Sensor Body
- ▶ Failure of High Impedance Preamplifier in Sensor
- ▶ Failure of Temperature Compensation Element
- ▶ Excessive Coating of the Reference Electrode

In addition, the analyzer performs continuous health checks on its own circuits. Firmware diagnostics include checksum and EEPROM on power up, code space checksum and CRC on power up (and approximately every five minutes thereafter), and continuous stack checking and watchdog timer.

For additional information about the specific fault(s), the user need only access the “DIAG” menu and follow the prompts. This procedure not only identifies specific faults, but also guides the user to corrective action without referring to an instruction book.

INTELLIGENT CALIBRATIONS

Calibration routines are designed for simplicity and elimination of errors. All procedures are self-prompting. Two calibration routines are available. A “manual” calibration is for users who prefer to edit and enter the pH values of their buffer solutions, and an “automatic” calibration provides a buffer-recognition mechanism which locks in on the buffer value most closely representing the combination of millivolts and temperature values being reported from the sensor. User-programmable stability parameters help prevent the analyzer from accepting calibration data until both the pH and temperature signals from the probe have stabilized. Three tables of buffer values are preprogrammed in the analyzer. For flexibility, a custom buffer table may be user-programmed for unusual application requirements.

CHOICE OF DIGITAL COMMUNICATIONS

The 875PH Analyzer provides maximum flexibility of digital communications. The basic instrument, with two printed wiring assemblies (PWAs), provides two analog outputs. For users who require digital communication, a third (optional) PWA for HART communication protocol provides connection between the analyzer and host. This PWA can be installed in the basic analyzer, or can be installed in the field at a later time.

The optional HART PWA contains nonvolatile memory, which allows the module to store its unique communication configuration parameters. Functions available via the digital communication option include:

- ▶ View Measurement Data
- ▶ View Analyzer Status Data
- ▶ Perform Analyzer Configuration
- ▶ Upload and Download Configuration Data
- ▶ Perform System Calibration
- ▶ View Sensor and Analyzer Diagnostics
- ▶ Place the Analyzer on Hold

COMPATIBLE WITH WIDE RANGE OF SENSORS

The analyzer contains an integral high impedance preamplifier, thus permitting it to be used with virtually any glass pH or noble metal ORP sensor. Also, the analyzer can be programmed to accept any of the three common temperature compensator inputs – 100 Ω platinum RTD, 1000 Ω platinum RTD, and Balco 3000 Ω RTD. This facilitates the use of the 875PH with many common non-Foxboro pH and ORP sensors. When a nonpreamplified sensor is used, the Foxboro sensor cable length is limited to 15.2 m (50 ft). Where the distance between the sensor and transmitter is greater than 15.2 m (50 ft), the Foxboro DolpHin PH10 and ORP10, 871PH, and 871A pH/ORP sensors are offered with integral preamplifiers, thus allowing the cable length to extend to 152 m (500 ft). See Figure 1 for Foxboro sensors compatible with the 875PH Analyzer.

DUAL ALARMS AND DUAL 4 to 20 mA OUTPUTS

Two independent, isolated alarm relays are standard. Either alarm is configurable as **off** (nonfunctional) or **on**. When **on**, the alarm is configurable to go **active** (energize relay), or **inactive** (de-energize relay), while passing above or below a measurement setpoint. Each alarm may also be programmed for either hysteresis control, or control based on timing for trigger, on, and off. Two front panel LEDs indicate when in alarm.

There are also two independent, isolated 4 to 20 mA analog outputs that are standard. When the optional HART communications PWA is installed, the standard output #2 becomes disabled, and the HART output becomes the second analog output.

The alarms and outputs are each configurable to any of the following parameters:

- ▶ Primary Measurement
- ▶ Absolute Measurement (millivolts)
- ▶ Temperature

Additionally, the alarms can also be configured to “trip” based upon:

- ▶ Analyzer in Hold
- ▶ Analyzer Fault, Communication Fault, Sensor Fault, Out-of-Range Fault
- ▶ Sensor Auto-Service Cycle Engaged

Figure 1. Foxboro DolpHin 871A, 871PH, and EP460 pH, ORP, and ISE Sensors



QUICK AND INFORMATIVE STATUS

With a few simple keystrokes, the user gains access to all the information necessary to assess the performance of the pH loop. Among the parameters this “read only” mode accesses are:

- ▶ Process Temperature
- ▶ Slope of pH Sensor
- ▶ Absolute (Uncompensated) Millivolt Value from pH Sensor
- ▶ Analog Output Value in Milliamps
- ▶ Status of Glass Electrode
- ▶ Asymmetry Potential
- ▶ Resistance of Reference Electrode
- ▶ Resistance of Temperature Compensator
- ▶ Date of Last Calibration

MOUNTING FOR EITHER FIELD OR PANEL APPLICATIONS

There are two distinct Foxboro analyzer housings offered to meet your application needs.

For **field mounted** (surface or pipe mounting) use, the analyzer is housed in a tough, epoxy-painted, cast aluminum enclosure able to withstand the harshest field conditions. This enclosure provides the environmental and corrosion-resistant protection of NEMA 4X, CSA Enclosure 4X, and IEC IP65. All input/output wiring is accessible from the front of the instrument through a dedicated field compartment. The terminal connections within this compartment are accessed by simply removing a front cover.

For **panel mounted** applications, a molded plastic enclosure with minimal depth behind the user’s panel, saves space, is light weight, and reduces cost. Direct access (no cover) to the wiring terminals is available from the rear of the instrument. This version is rated NEMA 1; however, the front panel meets NEMA 4X requirements when attached to the user’s panel, and gasketed in place with the supplied gasket.

Both field and panel mounted units have large spade lug terminals for sensor connections to facilitate installation, calibration, and maintenance. Either unit can also be provided with an optional Plexiglas storm door to help prevent accidental activation of the front panel controls, and for dust and hose-down protection. See “Dimensions-Nominal” section for mounting and dimensional information.

SINGLE UNIT FOR EITHER pH, ORP OR ION SELECTIVE ELECTRODES (ISE)

Each 875PH Analyzer is configurable for either pH, ORP, or ion selective electrode (ISE) measurement. This feature is important for OEM customers and systems integrators who supply systems requiring many kinds of analytical measurements. Examples are waste water treatment systems, cooling tower control systems, and odor control systems. Also, this feature minimizes spares inventory for instruments used as loaners or replacements for equipment supplied to end users.

HISTORY LOG

End users' compliance to ISO⁽¹⁾, GMP⁽¹⁾, and other quality and validation systems are enhanced by the Model 875PH's history log function.

The history log contains up to 100 time and date stamped reported errors, faults, and system-related events. Examples of entries in the history log are:

- ▶ Entry Into and Exit From Configuration, Calibration and Hold Modes
- ▶ Changes to Configuration, Calibration, and Hold
- ▶ Analyzer Power Restored after Outage
- ▶ Passcode Changed
- ▶ Alarm 1 or Alarm 2 Activated
- ▶ Errors Temporarily Cleared
- ▶ Sensor Faults
- ▶ Analyzer Faults

SECURE DATA AND CALIBRATIONS

Three protection levels guard against unauthorized configuration/calibration changes, loss of data, and/or invalid measurement signals. The first passcode permits access to routine maintenance, including calibration and basic output hold. The second passcode permits changes to all first level parameters, plus advanced output hold and basic configuration. The third passcode permits changes to all second level parameters, plus advanced configuration and all passcode changes.

Data stored in EEPROM obviates the need for battery backup. Measurement loop security is enhanced by a user programmable "fail signal" parameter activated by analyzer faults and any enabled sensor faults. This "fail signal" parameter forces the analyzer output to any user-defined value between 3.8 and 20.5 mA.

REMOTE AUTO-SERVICE

pH sensors, by their nature, require routine, often frequent maintenance. They must be checked, cleaned, and calibrated periodically.

The 875PH allows automating of the time-consuming and sometimes hazardous process of cleaning and calibrating sensors. With its auto-service function, the 875PH sends a signal to a user-supplied control instrument, which sequences the removal of the sensor from the process, the sensor cleaning, calibration, and re-installation, all automatically. While the sensor is being cleaned, the analyzer is in a normal measurement mode. When calibration starts, the analyzer executes a single or two-point solution calibration, using preprogrammed timing intervals and measurement/temperature stability parameters to determine when to accept low and high calibration values.

The auto-service cycle can be initiated in any of four ways. Methods include manual initiation, timed initiation, initiation from a remote device (e.g., PLC), and initiation due to a diagnostic condition.

Benefits to the user are a reduction in hands-on time for cleaning and calibration, as well as reduced risk of exposure to hazardous fluids.

HUMAN INTERFACE

The local Human Interface allows configuration, calibration, status, and fault location without the need of a hand-held terminal. This interface consists of MODE Indicators, a 2-line Display area, a Bargraph Display, two Alarm Indicators, MODE and ENTER keys, LEFT and RIGHT arrow keys, and UP and DOWN arrow keys. The backlit measurement display characters are 15 mm (0.6 in) high to allow easy reading from a distance. See Figure 2 for the Human Interface configuration, and Table 1 for a description of the indicators and controls.

The display area shown in Figure 2, in addition to indicating measurement data, is also used to display different screens. Figures 3 and 4 show the display area with a configuration screen and a status screen, respectively.

1. ISO = International Standards Organization; GMP = Good Manufacturing Practice.

Figure 2. Human Interface Layout

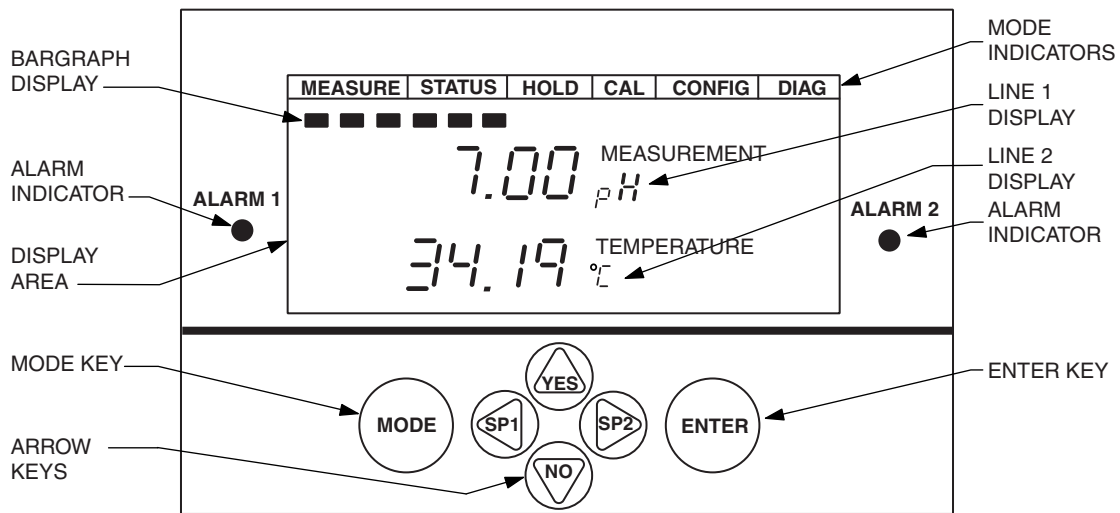

Figure 3. Configuration Screen

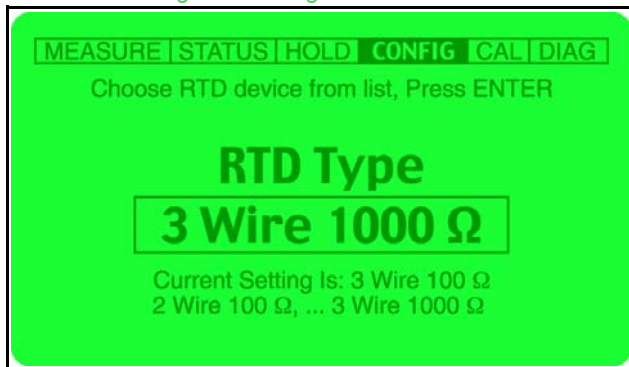

Figure 4. Status Screen

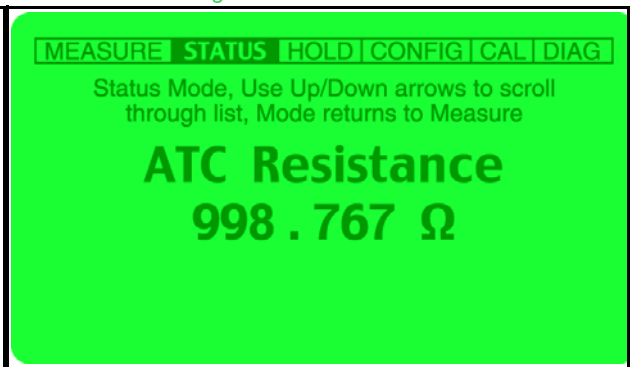

Table 1. Human Interface Indicators and Controls

Control/Indicator	Function
MODE Indicators	The current operating mode indicator is illuminated. While in Hold mode, the Hold indicator blinks.
DISPLAY Area <ul style="list-style-type: none"> ▶ Bargraph ▶ Line 1 ▶ Line 2 	The display is a graphic panel that shows information in combinations of alphanumeric and special characters, and a decimal point. <ul style="list-style-type: none"> ▶ Displays percent-of-range of the Line 1 value on the display. ▶ Displays measurements in Measure mode. ▶ Displays measurements in Measure mode.
ALARM Indicators	Alarm 1 (Alarm 2) indicator is illuminated when Alarm 1 (Alarm 2) is active.
MODE Key	Each press of the Mode key selects the next operating mode (Measure, Status, Hold, Calibrate, Configure, and Diagnostic).
RIGHT Arrow Key	<ul style="list-style-type: none"> ▶ Moves you forward through the menu structure. ▶ Shifts the cursor to the right in a data entry field. ▶ Offers a “short cut” to the Alarm 2 set point when in Measure Mode.
LEFT Arrow Key	<ul style="list-style-type: none"> ▶ Moves you backward through the menu structure. ▶ Shifts the cursor to the left in a data entry field. ▶ Offers a “short cut” to the Alarm 1 set point when in Measure Mode.
UP Arrow Key	<ul style="list-style-type: none"> ▶ Increments a numeric value or character when in a data entry field. ▶ Shifts the items down when in a picklist menu. ▶ Answers Yes to a question.
DOWN Arrow Key	<ul style="list-style-type: none"> ▶ Decrements a numeric value or character when in a data entry field. ▶ Shifts the items up when in a picklist menu. ▶ Answers No to a question.
ENTER Key	Enters and saves the changed menu picklist choices or numeric value or character data entry.

OPERATING, STORAGE, AND TRANSPORTATION CONDITIONS

Influence	Reference Operating Conditions	Normal Operating Conditions	Operative Limits	Storage and Transportation Limits
Ambient Temperature	23 ±2°C (73 ±4°F)	-10 to + 65°C (a) (14 to 149°F)	-20 and +75°C (a) (-4 and +165°F)	-40 and +85°C (-40 and +185°F)
Relative Humidity	50 ±10%	5 to 95% Noncondensing	5 and 95% Noncondensing	5 and 95% Noncondensing
Supply Voltage, ac (b)	Rated Voltage ±1%	Rated Voltage -15 to +10%	Rated Voltage -20 and +15%	Not Applicable
Supply Frequency, ac	50 or 60 Hz, ±1%	50 or 60 Hz, ±3 Hz	50 and 60 Hz, ±3 Hz	Not Applicable
Supply Voltage, dc	24 V dc, ±1%	19.2 to 33.6 V dc	18 to 36 V dc	Not Applicable
Vibration - Standard Construction ▶ Field Mount ▶ Panel Mount	▶ 1 "g" (10 m/s ²) between a frequency of 5 and 200 Hz ▶ 0.25 "g" (2.5 m/s ²) between a frequency of 5 and 200 Hz			Note (c)
Vibration - (d) Rugged Construction	Vibration qualified per MIL Std. 167-1 for use as a Navy shipboard device.			Note (c)
Mechanical Shock - (d) Rugged Construction	Mechanical shock qualified per MIL Std. S-901; Grade A, Class I, Type C, for use as a Navy shipboard device.			Note (c)
Pollution Degree	3, per ANSI/ISA S82.01			Not Applicable
Installation Category (Overvoltage Category)	II, per ANSI/ISA S82.01			Not Applicable
Mounting Position	Generally Upright	Any Position	Any Position	Not Applicable

- a. Refer to the Electrical Safety Specifications section for a restriction in ambient temperature with certain electrical certifications.
- b. Rated Voltage is 24, 100, 120, 220, or 240 V ac, 50 or 60 Hz. See Model Code section.
- c. During transportation, the packaged Analyzer can withstand normal handling and shipping conditions without damage.
- d. Rugged construction is only available with Field Mount Analyzers.

PERFORMANCE SPECIFICATIONS

*(Analyzer Specifications under Reference Operating Conditions unless otherwise specified.
Refer to Sensor Literature for Sensor Specifications.)*

Measurement Accuracy, Repeatability, and Stability - Digital Output

Measurement	Full Scale Range	Accuracy	Repeatability	Stability (a)
pH	-2 to +16 pH	±0.018 pH	±0.018 pH	±0.045 pH
ORP	-2000 to +2000 mV	±4 mV	±4 mV	±10 mV
ISE	0 to 0.9999 ppm	±0.001 ppm	±0.001 ppm	±0.0025 ppm
ISE	0 to 9.999 ppm	±0.01 ppm	±0.01 ppm	±0.025 ppm
ISE	0 to 99.99 ppm	±0.1 ppm	±0.1 ppm	±0.25 ppm
ISE	0 to 999.9 ppm	±1 ppm	±1 ppm	±2.5 ppm
ISE	0 to 9999 ppm	±10 ppm	±10 ppm	±25 ppm

a. Stability is over a 6-month period.

Temperature Accuracy (Includes Repeatability)

Sensor Description	Accuracy
2-wire, 100 Ω, Plat. RTD (a)	±0.2°C (±0.36°F)
3-wire, 100 Ω, Plat. RTD (a)	±0.1°C (±0.18°F)
2-wire, 1000 Ω, Plat. RTD (a)	±0.2°C (±0.36°F)
3-wire, 1000 Ω, Plat. RTD (a)	±0.1°C (±0.18°F)
2-wire, 3000 Ω, Balco RTD (a)	±0.2°C (±0.36°F)

a. 2-wire platinum and Balco RTDs must be calibrated for cable length.

Measurement Accuracy - Analog Output

Measurement Digital Accuracy plus an additional ±0.05% of output span.

Maximum Drift over Six Months

±0.1% of full scale (noncumulative) for the temperature measurement.

Response Time

PRIMARY MEASUREMENT

3 seconds or better, depending on configuration

TEMPERATURE MEASUREMENT

<10 seconds, 2- or 3-wire temperature sensor

Output Noise (Analog Outputs)

±0.25% of output span (measured with a 500 Hz bandwidth)

Output Load Effect

<0.05% of output span value; effect is on output for a change in loop resistance of up to 800 Ω.

Vibration Effect (Sensor not included)

Less than 0.1% of output span

Mounting Position Effect

Less than 0.01% of output span for all positions.

Ambient Temperature Effect

DIGITAL MEASUREMENT

±0.05% of output span per °C

ANALOG OUTPUT

±0.05% of output span per °C

Relative Humidity Effect

DIGITAL MEASUREMENT

±0.5% of output span, from 50 to 95% RH at 40°C (104°F)

ANALOG OUTPUT

±0.5% of output span, from 50 to 95% RH at 40°C (104°F)

Power Supply Effect

±0.5% of output span for a +10% voltage shift

±0.75% of output span for a -15% voltage shift

±0.1% of output span for a 3 Hz shift at 50 or 60 Hz

RFI Immunity⁽²⁾

Output error of < 5% of full scale when tested with field strength of 10 V/m from 80 to 1000 MHz with 80% amplitude modulation at 1 kHz (IEC 61000-4-3).

RFI Emission⁽²⁾

30 to 1000 MHz with 47 dB (µV/m) at 10 m (EN 50081-2)

CFI Immunity⁽²⁾

10 V (rms) from 0.15 to 80 MHz with 80% amplitude modulation at 1 kHz (IEC 61000-4-6).

CFI Emission⁽²⁾

0.15 to 30 MHz and 73 dB (µV) QP (EN 50081-2).

High Frequency Transient⁽²⁾

Withstands high frequency transient on ac power line of +/-2 kV, 5 kHz and 5 nS rise time pulses (IEC 61000-4-4).

Lightning Transient⁽²⁾

Withstands shock wave discharge of +/-4 kV with Tr/Th of 1.2/50 µS (IEC 61000-4-5).

Electrostatic Discharge⁽²⁾

6 kV contact 8 kV air discharge, Criteria A (IEC 61000-4-2).

Magnetic Field Immunity

30 A (rms)/m at 50/60 Hz (IEC 61000-4-8)(2).

Voltage Dips (ac Power Port)

10 ms at -30% Criteria B and 10 ms at -60% Criteria C (IEC 61000-4-11).

Voltage Interruptions (ac Power Port)

>95% at 5 s, Criteria C (IEC 61000-4-11).

Voltage Fluctuations (ac Power Port)

230 V ac +/-10% and 50 Hz +/-5%, 15 min (IEC SC77A WG6)

Common Mode Rejection Ratio

120 dB, dc; or 50/60 Hz, ac; between loop and sensor (42 V peak maximum)

2. All input/output cables must be installed in metallic conduit. Panel mount unit must be installed in metallic enclosure.

FUNCTIONAL SPECIFICATIONS

Power Requirements

24, 100, 120, 220, or 240 V ac, 50 or 60 Hz; 24 V dc

Power Consumption

Up to 17 W

Sensor Inputs

A single sensor may be connected to the analyzer.

Sensor Compatibility**FULL COMPATIBILITY**

Foxboro DolpHin PH10/ORP10, 871A-1, -3, and -4; 871PH-3, -4, -5, and -6; and all EP460 Series Sensors

COMPATIBILITY LESS FULL DIAGNOSTIC SUITE

Foxboro 871A-2, and 871PH-1 and -2 Sensors

COMPATIBILITY WITH NON FOXBORO SENSORS

The 875PH Analyzer is also compatible with non Foxboro sensors without integral preamplifiers, and compatible temperature sensing elements.

Note: The analyzer provides power for a sensor preamplifier. The screens (shields) for the sensor electrode cable are driven to minimize external interference.

Sensor Preamplifier Power

+5 V dc $\pm 3\%$ through 680 Ω

-5 V dc $\pm 3\%$ through 680 Ω

Input Impedance

10^{12} Ω minimum on measurement and reference inputs. For use with or without external preamplifier. Screen (shield) drive provided for both measurement and reference.

Primary Measurement Ranges**pH MEASUREMENT**

-2 to +16 pH

ORP MEASUREMENT

-2000 to +2000 mV

ISE MEASUREMENT

0 to 9999 ppm

Temperature Measurement Ranges**100 Ω PLATINUM RTD (2 and 3 wire)**

-20 to +200°C (-4 to +392°F)

1000 Ω PLATINUM RTD (2 and 3 wire)

-20 to +200°C (-4 to +392°F)

3000 Ω Balco RTD

0 to 100°C (32 to +212°F)

Temperature Compensations**TYPES**

Absolute, glass pH, antimony pH, or ISE; (no compensation for ORP measurement). Chemical compensations for 1 ppm ammonia and custom.

RANGE

-5 to +140°C (23 to 284°F), sensor dependent

Note: Range for ammonia compensation only is 0 to 100°C (32 to 212°F).

Automatic Buffer Recognition

Analyzer has three tables of preprogrammed pH buffer values; American, European, and National Institute of Standards and Testing (NIST). Also, one user programmable table is available. Each table contains three value sets of pH and temperature.

Analog Outputs

- ▶ Dual Isolated Outputs
- ▶ Outputs Configurable to:
 - Temperature Compensated pH or ISE
 - Absolute pH, ORP, or ISE (mV in all cases)
 - Temperature
- ▶ 4 to 20 mA Linear Output
- ▶ Analog Output Hold - from 3.8 to 20.5 mA dc
- ▶ Loop Power to support up to 800 Ω of Loop Resistance
- ▶ Analog Output Zero Setting adjustable to 100% of Full Scale Range. Minimum Difference of 5% between Zero and span Ranges
- ▶ Analog Output Programmable to any Value between 3.8 and 20.5 mA, upon Failure.

Analog Output Isolation

Outputs are isolated from ground and from each other.

Minimum Output Span Limit

5% of full scale

Isolated Output Load

Up to 800 Ω

Optional Digital Communications

HART Communication Protocol.

Digital Inputs

Three digital inputs are provided to allow activation of instrument functions due to a signal from a remote device (e.g., PLC). Digital inputs 1 and 2 are utilized to place the instrument into an auto-sensor service cycle. Each auto-sensor service cycle may be configured individually. For example, Cycle 1 might be a “clean only”, while Cycle 2 might be a full “clean with a 2-point calibration” cycle. Digital input 3 is used to place the instrument in HOLD. This feature is important in batch applications, where the sensor may be temporarily out of contact with the process solution. By automatically putting the 875PH Analyzer in HOLD, the user can avoid actuating alarms until the sensor is back in contact with the process medium.

Specifications for Digital Inputs/Outputs

- ▶ Terminal DV+ power: 4.5 V \pm 3% at 10 mA max.
- ▶ Terminal DV- power: -20 V \pm 1% at 10 mA max.

Above voltages are provided by the Foxboro 875 Analyzer

- ▶ Digital Inputs 1 through 4
 - High Logic: User must verify voltage to be between 2.7 and 10 V
 - Low Logic: User must verify circuit to be open, or less than 0.8 V
 - Digital inputs are only to be used with the +4.5 V/-20 V outputs provided by the Foxboro 875 analyzer.

Contact Global Customer Support for sample wiring schemes.

Alarms

Two configurable alarms can be independently set as high or low alarms based on the primary measurement, input temperature, or a diagnostic.

Each alarm is configurable for the following:

- ▶ Temperature Compensated pH or ISE
- ▶ Absolute pH/ORP/ISE (millivolts)
- ▶ Temperature
- ▶ Diagnostic Fault, Freely Programmable
- ▶ Initiate Sensor Auto-Service Cycle

Adjustable hysteresis for both alarms is 0 to 100% of full scale. Feed, delay, and trigger times are adjustable from 0 to 99.99 minutes.

Alarm Outputs

Mechanical Relay – Two independent, isolated, Form “C” contacts rated 2 A at 24 V dc, 5 A at 250 V ac, noninductive. Inductive loads, such as a motor or solenoid, can be driven with external shock wave absorbing devices across contact terminations. Contacts are not powered by the 875 Analyzer.

Displayed Data

Each of the two lines of the display area can be configured to present:

- ▶ Temperature Compensated pH or ISE
- ▶ Absolute pH/ORP/ISE (millivolts)
- ▶ Temperature
- ▶ Analog Output, Channels 1 or 2
- ▶ Scan Mode - any of the above Parameters at adjustable Viewing Cycles

Measurement Display Units

pH, mV, mA, °C, °F, and ppm (parts per million)

Measurement Damping

Adjustable to None, 5, 10, 20, 40, or 120 seconds, where None is the base response time for the analyzer.

Data Storage

Configuration, calibration, and operating parameters stored in nonvolatile memory for >5 years.

Operating Modes

- ▶ On-Line Measurement – Continuously outputs measurement data to front panel display and serial communication port
- ▶ On-Line Status – Provides current information
- ▶ Off-Line Calibration – Ability to calibrate analyzer full scale for primary measurements and temperature
- ▶ Off-Line Configuration – User can configure all ranges, units of measure, alarms, analog outputs, and other parameters
- ▶ Hold

Background Self-Diagnostics

ANALYZER

- ▶ Checksum and EEPROM on Power Up of Database
- ▶ Code Space Checksum and CRC on Power Up and approximately every five minutes thereafter
- ▶ Stack Checking - Continuous
- ▶ Watchdog Timer - Continuous

SENSOR

Broken Glass Electrode, aging glass electrode, liquid leakage, preamp failure, temperature device failure, fouled reference junction, low slope. Note: Check sensor specifications for diagnostics capability.

OTHER

- ▶ 4 to 20 mA Output Out-of-Range
- ▶ Temperature Compensation Out-of-Range
- ▶ Measurement Out-of-Range.

Logbook Function (Also see Previous “History Log” Section)

Events such as warning messages, calibrations, and configuration activity stored in nonvolatile memory. Time-of-day and date stamped with each stored event. Storage accommodates 100 events.

ELECTRICAL SAFETY SPECIFICATIONS

Testing Laboratory, Type of Protection, and Area Classification	Application Conditions (a)	Electrical Safety Design Code
CSA ordinary locations.	For panel mounted units, see note (b).	C
CSA for Class I, Division 2, Groups A, B, C, and D; Class II, Division 2, Groups F and G; and Class III, Division 2 hazardous locations.	Temperature Class T4. For panel mounted units, see note (b).	
FM ordinary locations.	For panel mounted units, see note (b).	F
FM nonincendive for Class I, Division 2, Groups A, B, C, and D; Class II, Division 2, Groups F and G; and Class III, Division 2 hazardous locations.	Temperature Class T4. For panel mounted units, see note (b).	
IECEx protection 'n' for Zone 2; Ex nA nL nC [nL] IIC.	Temperature Class T4 at a maximum ambient of 60°C.	D
UL ordinary locations.	---	U

a. Specifications for the analyzers may differ from standard specifications. Refer to MI 611-206 for CSA and FM specifications, entity parameters, and special conditions of use.

b. Panel-mounted unit must be installed as follows:

For Ordinary and Class I, Division 2 locations: install in a protective enclosure to help prevent access to live parts.

For Class II and Class III Division 2 locations: install in a dusttight enclosure.

NOTE: The enclosures above must meet the ingress protection level required by the application, up to NEMA 4X or IP65.

PHYSICAL SPECIFICATIONS

Analyzer Enclosure

FOR PANEL MOUNTING

The housing is made of Noryl plastic and meets NEMA 1 requirements for general purpose, indoor applications. However, when installed in a panel, the front surface is protected by a gasketed, epoxy-painted, die cast, low copper aluminum bezel. This provides the front surface with the environmental and corrosion resistant protection of NEMA Type 4X, and NEMA 1 for the rear module.

FOR FIELD MOUNTING

The enclosure (housing, front bezel, and covers) is made from a die cast, low copper, aluminum alloy protected with an epoxy paint finish. The entire enclosure assembly provides the environmental and corrosion resistant protection of NEMA Type 4X, CSA encl. 4X, and IEC IP65.

Enclosure Mounting

The enclosure can be mounted to a panel, or field mounted to a surface or nominal DN 50 or 2-in pipe. When field mounted, a painted, low carbon steel bracket and a kit of mounting hardware is provided.

Sensor Cable Length

FOR PREAMPLIFIED SENSORS

Up to 150 m (500 ft)

FOR NONPREAMPLIFIED SENSORS

Up to 15 m (50 ft)

Electrical Connections

FIELD MOUNTED ENCLOSURE

Terminals are provided within the lower enclosure compartment. Field wires enter through holes in the bottom of the enclosure sized to provide for wiring conduit or cable glands. An easily removable bottom front cover, with captive screws, helps protect the field wiring compartment.

PANEL MOUNTED ENCLOSURE

Field wiring terminals are provided at the rear, stepped surfaces of the housing. They are directly accessible without removing any cover(s).

Approximate Mass

PANEL MOUNTED ENCLOSURE

1.8 kg (4 lb)

FIELD MOUNTED ENCLOSURE

3.3 kg (7.3 lb)

Wiring Terminal Configuration and Description

Figure 5 shows the terminal configuration for both the panel and field mounted enclosures. Table 2 describes the use for each terminal.

Figure 5. Wiring Terminal Configuration.

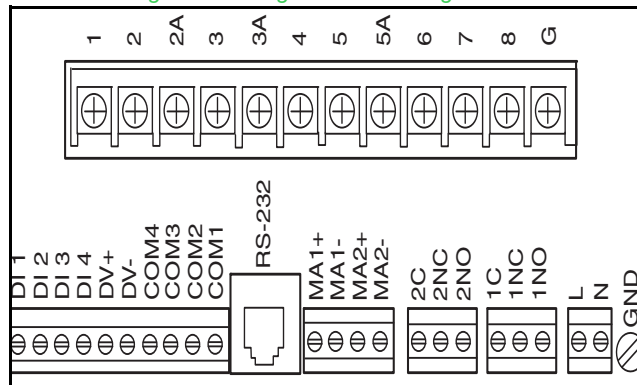

Table 2. Wiring Terminal and Description

Sensor Connections	
Terminal	Terminal Description
1	RTD Return
2	RTD Drive
2A	RTD Cable Length Compensation
3	Measurement Electrode
3A	Measurement Screen (Shield)
4	Solution Ground
5	Reference Electrode
5A	Reference Electrode Screen (Shield)
6	Sensor Power, +
7	Sensor Power, -
8	Diagnostic
G	Not Used
Digital, Analog, Alarm, and Power Connections	
DI 1, 2, 3, 4	Digital Inputs
DV+, DV-	Power Source for Digital Inputs
COM 1, 2, 3, 4	Digital I/O Communications
MA1+, MA1-	Analog Output 1
MA2+, MA2-	Analog Output 2
1C, 1NC, 1NO	Alarm 1
2C, 2NC, 2NO	Alarm 2
L	Power, Line (Black)
N	Power, Neutral (White)
GND	Power, Ground (Green)

OPTIONAL FEATURES AND ACCESSORIES

Option -A: Storm Door

This plexiglas door is attached to the front surface of the enclosure and hinges upward. It is used to help prevent accidental or inadvertent actuation of front panel controls, and also useful in dusty or hose down environments. The door is clear plastic to allow viewing of the display when closed, and also hinged to allow ready access to front panel controls.

Option -C: Digital HART Communications Protocol

HART protocol replaces the secondary 4 to 20 mA measurement output signal. It operates using the frequency shift keying (FSK) principle. Diagnostics and measurements are available from the HART Communicator connected to the two-wire loop (carrying the 4 to 20 mA output) by using a bidirectional digital signal superimposed on the 4 to 20 mA signal. Simultaneous analog and digital communications are thus provided without interrupting (or disturbing) any analog signal transmission that might be occurring. Both a Communicator and a PC-Based Configurator may be connected to each HART loop (Figure 6). A minimum resistance of 250 ohms must be available in the communication circuit. Two measurement updates per second are communicated. Also, with HART Communications, up to fifteen analyzers in a multidrop configuration can be connected on a single twisted pair of wires, or over leased telephone lines (Figure 7).

Options -N and -P: Rugged Construction

Rugged construction is offered with Options -N and -P. These options are only available with the 120 V ac Analyzer, and require the selection of the reinforced mounting bracket (Enclosure Mounting Selection 4). The rugged construction design allows hard mounting of the analyzer for Navy shipboard installations without performance degradation. They have been vibration tested per MIL Standard 167-1, and mechanical shock tested per MIL Standard 901, Grade A, Class I, Type C.

Figure 6. Point-to-Point Communications 4 to 20 mA Output with HART

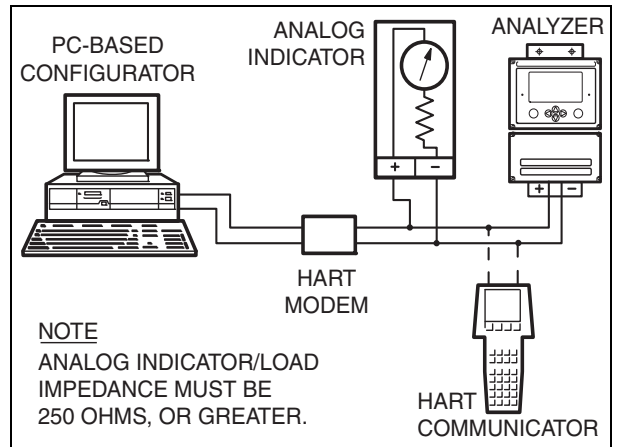
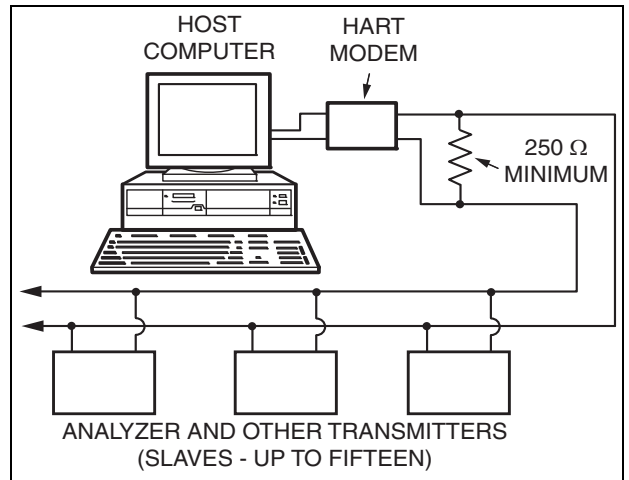

Figure 7. Typical Multidrop Configuration 4 to 20 mA Output with HART



MODEL CODE

<u>Description</u>	<u>Model</u>
pH, ORP, or ISE (Ion Selective Electrode) Electrochemical Analyzer	875PH
<u>Supply Voltage and Frequency</u>	
120 V ac, 50 or 60 Hz (a)	-A
220 V ac, 50 or 60 Hz	-B
240 V ac, 50 or 60 Hz	-C
24 V ac, 50 or 60 Hz	-E
100 V ac, 50 or 60 Hz	-J
24 V dc (b)	-D
<u>Enclosure Mounting</u>	
Panel Mounting - Standard Construction (c)	1
Field Mounting to a DN50 or 2-in Pipe - Standard Construction	2
Field Mounting to a Surface, with standard mounting bracket - Standard Construction	3
Field Mounting to a Surface, with reinforced mounting bracket - Rugged Construction (a)	4
<u>Electrical Safety (also see "Electrical Safety Specifications" section)</u>	
CSA Ordinary and Division 2 Locations, NI (c)	C
FM Ordinary and Division 2 Locations, NI (c)	F
IECEX protection n for Zone 2; Ex nA nL nC [nL] IIC	D
UL (Underwriter's Laboratory) Ordinary Locations	U
<u>Optional Selections</u>	
Storm Door	-A
Digital HART Communication and 4 to 20 mA Output	-C
Rugged Construction, shock and vibration, with 4 to 20 mA Analyzer outputs (a)	-N
Rugged Construction, shock and vibration, with 0 to 10 V Analyzer outputs (a)	-P
Example: 875PH-A3F-A; 875PH-B2C-AC	

- a. The rugged construction options -N and -P are available only with:
 - Supply voltage Code -A (120 V ac, 50 or 60 Hz)
 - Enclosure Mounting Code 4 (field-mounted enclosure with reinforced mounting bracket)
- b. The 24 V dc power selection provides a volts dc four-wire analyzer (it is not a loop powered 4 to 20 mA device).
- c. Panel mounted unit must be installed as follows:
 - For Ordinary, and Class I, Division 2 locations: install in a protective enclosure to help prevent accessibility to live parts.
 - For Class II, and Class III, Division 2 locations: install in a dusttight enclosure.

NOTE: The protective and dusttight enclosures above must meet the ingress protection level required by the application, up to NEMA 4X or IP65.

DIMENSIONS-NOMINAL

mm
in

PANEL MOUNTED ENCLOSURE

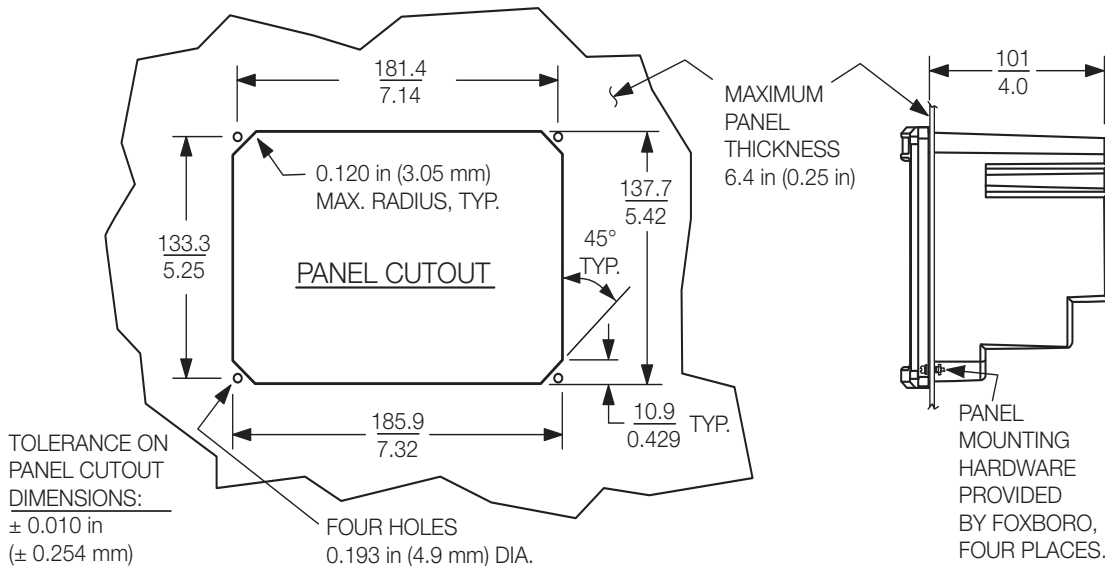
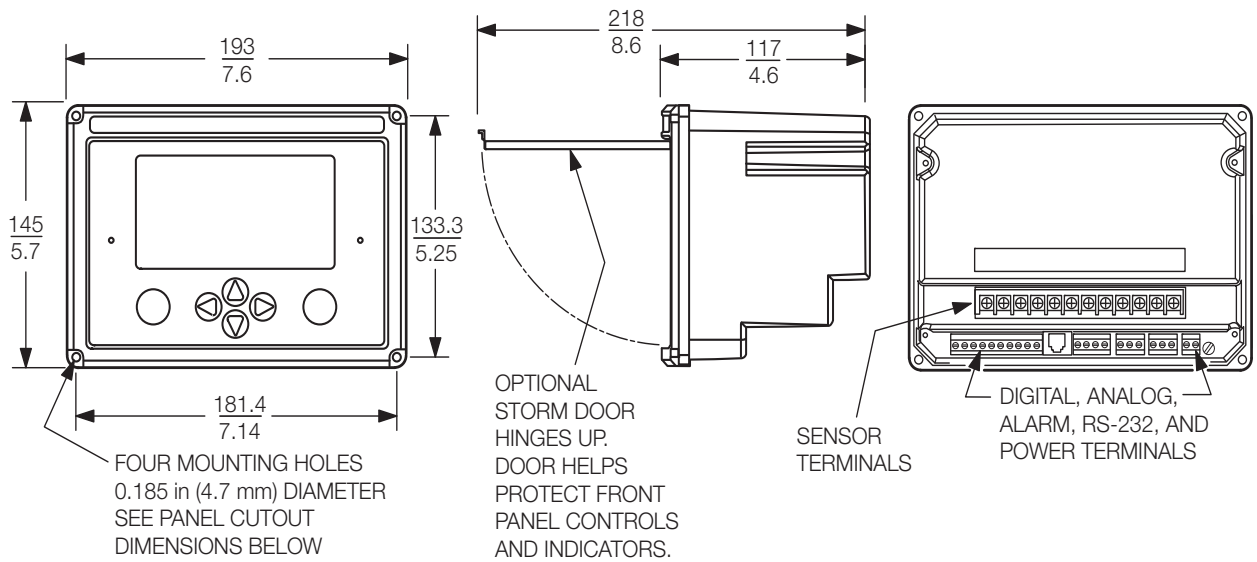

mm
in

FIELD MOUNTED ENCLOSURE
(SEE NEXT PAGE FOR ENCLOSURE MOUNTED TO A SURFACE AND PIPE)

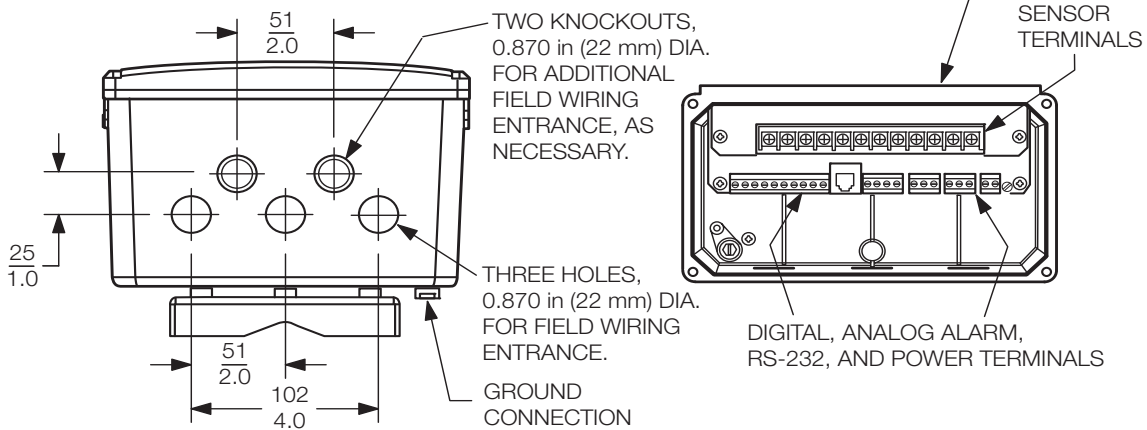
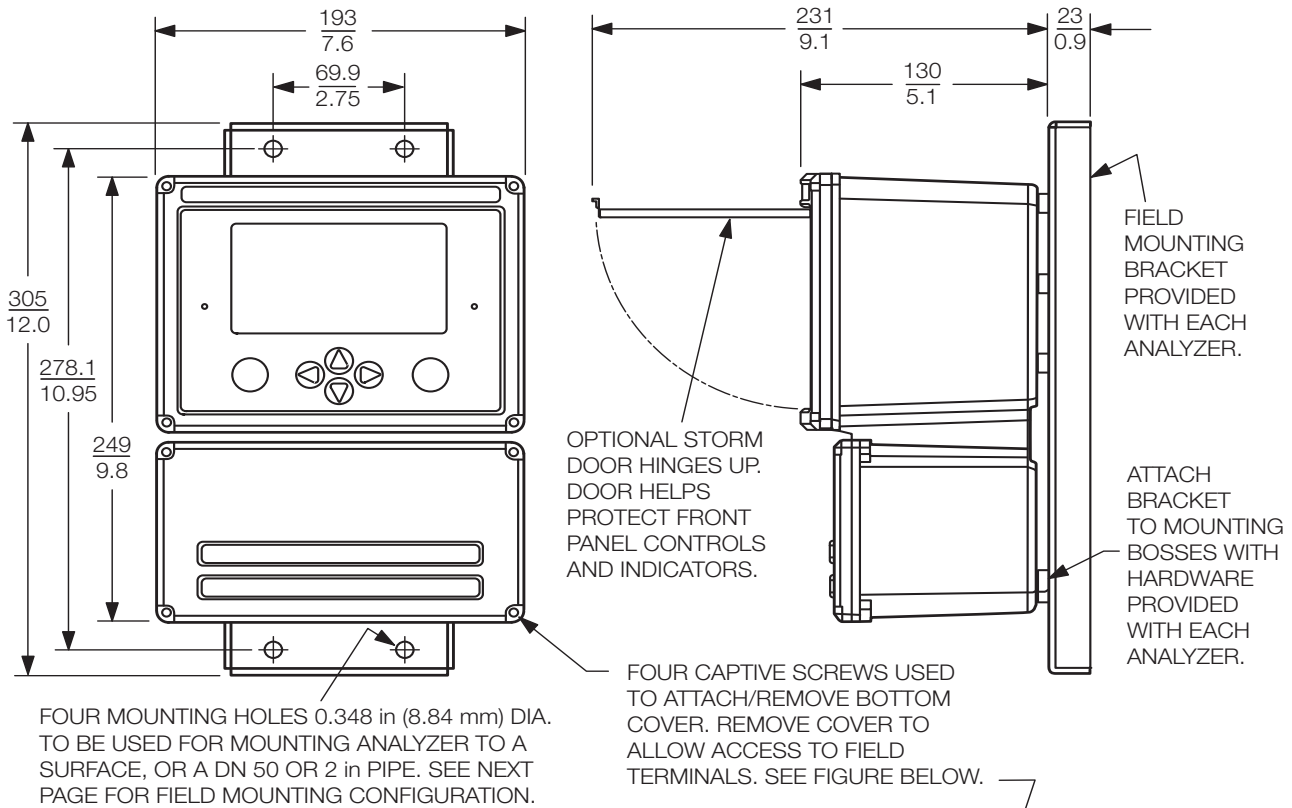

$\frac{\text{mm}}{\text{in}}$

SURFACE MOUNTED ENCLOSURE

USE APPROPRIATE
HARDWARE TO FASTEN
BRACKET TO MOUNTING
SURFACE.

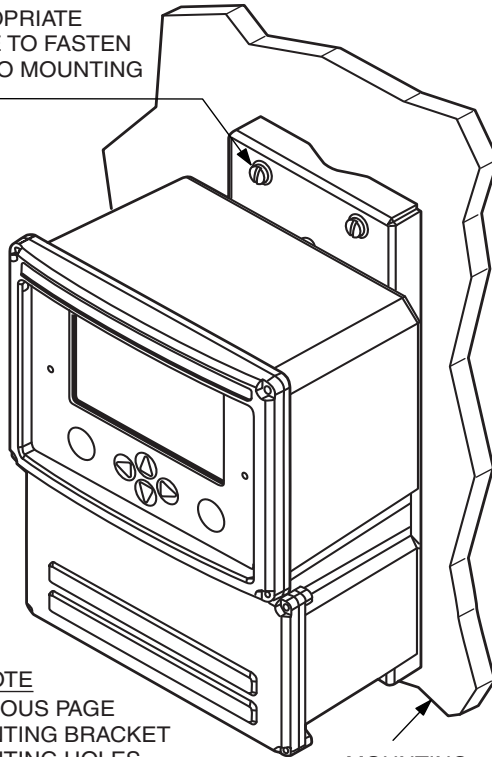

NOTE
SEE PREVIOUS PAGE
FOR MOUNTING BRACKET
AND MOUNTING HOLES
DIMENSIONAL DATA.

MOUNTING
SURFACE

PIPE MOUNTED ENCLOSURE

PIPE MOUNTING KIT
(U-BOLTS, WASHERS,
AND NUTS) PROVIDED
BY FOXBORO.

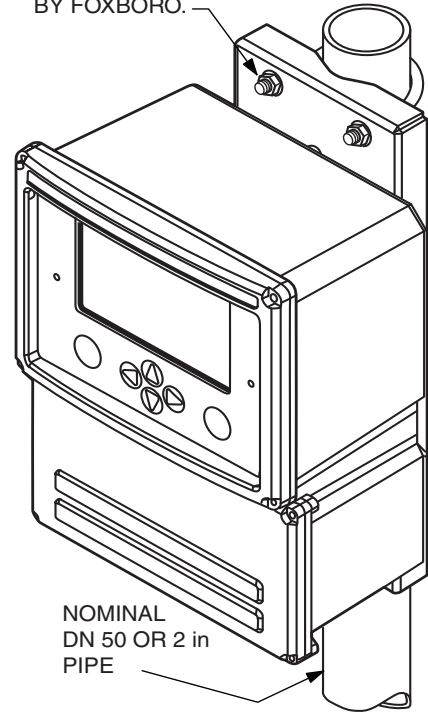

NOMINAL
DN 50 OR 2 in
PIPE

NOTES

ORDERING INSTRUCTIONS

- 1 Model Number
- 2 Measuring Electrode Type; Specify: Glass pH; Antimony pH; ORP; or ISE (specify type)
- 3 Analog Output Range, Channel 1 and Channel 2
- 4 Temperature compensation Input:
 - 100 Ω, 2-wire RTD (871A-1, -2; 871PH-1, -2)
 - 100 Ω, 3-wire RTD (all EP460 Series)
 - 1000 Ω, 2-wire RTD (871A-3; 871PH-5, -6)
 - 1000 Ω, 3-wire RTD (871A-4; 871PH-3, -4)
 - 3000 Ω Balco RTD
- 5 User Tag and Application

REFERENCE DOCUMENTS

Document Number	Document Description
PSS 6-1C2 A	871PH Series pH and ORP Sensors and Accessories
PSS 6-1C2 B	871A Series pH and ORP Sensors and Accessories
PSS 6-1C3 A	Dolphin Series pH and ORP Sensors and Accessories
MI 611-206	Intrinsic Safety Connector Diagrams - FM, CSA, and IECEx
MI 611-225	875PH Electrochemical Analyzer for pH, ORP, and ISE Measurements
Bulletin K99-2	EP460 Series, pH Sensors, Universal Mount
Bulletin K99-3	EP462 Series, pH Sensors, Twist-Lock Mount
Bulletin K99-4	EP466 Series, pH Sensors, Insertion/Retractable Mount

OTHER FOXBORO PRODUCTS

The Foxboro product lines offer a broad range of measurement and instrument products, including solutions for pressure, flow, analytical, temperature, positioning, controlling, and recording. For a list of these offerings, visit our web site at:

www.schneider-electric.com

Schneider Electric Systems USA, Inc.
 38 Neponset Avenue
 Foxboro, MA 02035
 United States of America
<http://www.schneider-electric.com>

Global Customer Support
 Inside U.S.: 1-866-746-6477
 Outside U.S.: 1-508-549-2424
<https://pasupport.schneider-electric.com>

Copyright 2000-2017 Schneider Electric Systems USA, Inc. All rights reserved.

Schneider Electric, Foxboro, and DolpHin are trademarks of Schneider Electric Systems USA, Inc., its subsidiaries, and affiliates. All other trademarks are the property of their respective owners.



by Schneider Electric