



Instruction

MI 022-310  
April 1999

# 13A d/p Cell<sup>®</sup> Transmitter

Installation and Operation



A Siebe Group Company



# Contents

<b>1. Introduction</b> .....	<b>1</b>
General .....	1
Principle of Operation .....	1
Standard Specifications .....	2
Installation .....	3
Transmitter Dimensions .....	3
Transmitter Mounting .....	3
Air Supply and Transmission Piping .....	4
<b>2. Liquid Flow Measurement</b> .....	<b>5</b>
Installation .....	5
Operation .....	6
System Fill Using Line Liquid .....	6
System Fill Using Seal Liquid .....	6
Transmitter Zero Adjustment .....	7
Putting Transmitter Into Operation .....	8
Taking Transmitter Out of Operation .....	8
<b>3. Gas Flow Measurement</b> .....	<b>9</b>
Installation .....	9
Operation .....	10
Filling System with Seal Liquid .....	10
Transmitter Zero Adjustment .....	11
Putting Transmitter Into Operation .....	11
Taking Transmitter Out of Operation .....	11
<b>4. Steam Flow Measurement</b> .....	<b>13</b>
Installation .....	13
Operation .....	14
Filling System with Water .....	14
Zero Adjustment .....	14
Putting Transmitter Into Operation .....	15
Taking Transmitter Out of Operation .....	15
<b>5. Liquid Level Measurement</b> .....	<b>17</b>
Installation .....	17

Measurement Piping .....	17
Seal Liquid .....	17
Reference Leg Details .....	17
Reference Adjustment .....	18
Adjustment Procedure .....	18
Formula to Calculate Output at Reference Level .....	19
<b>6. Calibration Formulas.....</b>	<b>21</b>
Either Open Tank or Closed Tank with Dry Leg .....	21
Closed Tank With Wet Leg .....	22

# 1. Introduction

## General

The 13A d/p Cell Transmitter (Figure 1) is a pneumatic force balance instrument that measures differential pressure and transmits a proportional pneumatic output signal. The transmitter is used in flow, liquid level, and other differential pressure applications.

Before putting the transmitter into operation, the user should ascertain that the wetted parts materials are compatible with the process.

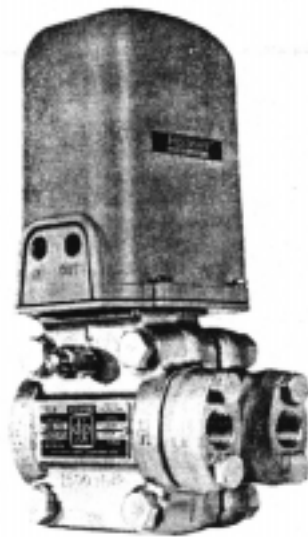

*Figure 1.*

## Principle of Operation

Refer to Figure 2. The high and low pressures of the variable to be measured are connected to opposite sides of a twin diaphragm capsule. The force on the capsule is transmitted through a flexure to the lower end of the force bar. The diaphragm seal serves both as a fulcrum for the force bar and as a seal for the pressure chamber. The force is transmitted through the flexure connector to the range bar which pivots on the range wheel.

Any movement of the range bar causes a minute change in the clearance between the flapper and nozzle. This produces a change in output pressure from the relay to the feedback bellows until the force on the feedback bellows balances the force on the diaphragm capsule.

The output pressure which is established by this force balance is the transmitted signal and is proportional to the differential pressure applied to the diaphragm capsule. This signal is transmitted to a pneumatic receiver to record, indicate, and/or control.

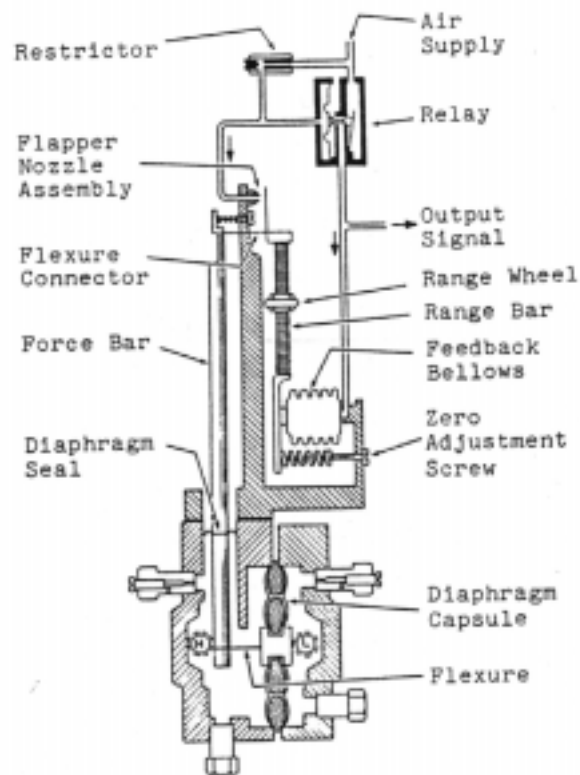

*Figure 2.*

## Standard Specifications

### Measurement Range Limits\*

Code M:  $\pm 62$  kPa or  $\pm 250$  inH<sub>2</sub>O

Code H:  $\pm 210$  kPa or  $\pm 850$  inH<sub>2</sub>O

### Span Limits

Code M: 5 and 62 kPa or 20 and 250 inH<sub>2</sub>O

Code H: 50 and 210 kPa or 200 and 850 inH<sub>2</sub>O

Static Pressure Limits: 14 MPa (2000 psi)

### Ambient Temperature Limits:

Normal Operating Conditions:  $-40$  and  $+120^{\circ}\text{C}$  ( $-40$  and  $+250^{\circ}\text{F}$ )

Operative Limits:  $-45$  and  $+140^{\circ}\text{C}$  ( $-50$  and  $+280^{\circ}\text{F}$ )

### Body Temperature Limits:

Normal Operating Conditions:  $-40$  and  $+120^{\circ}\text{C}$  ( $-40$  and  $+250^{\circ}\text{F}$ )

Operative Limits:  $-45$  and  $+175^{\circ}\text{C}$  ( $-50$  and  $+350^{\circ}\text{F}$ )\*\*

### Supply Pressure Limits:

Normal Operating Conditions: 120 and 150 kPa or 18 and 22 psi

Operative Limits: 240 kPa or 35 psi

Output Range: 20 to 100 kPa or 3 to 15 psi

Topworks Enclosure: Meets the requirements of IEC IP54, and provides the environmental protection of NEMA Type 3.

\*Nonzero-based ranges may require optional elevated or suppressed zero range kit. A negative value means that the higher pressure is applied to the “low pressure” side of the transmitter.

\*\*Topworks temperature must not exceed 140°C (280°F).

## Installation

### Transmitter Dimensions

Refer to Dimension Print DP 022-310.

### Transmitter Mounting

The transmitter can be mounted in any position. The pipe mounting bracket is installed on the opposite side from the process piping. See Figure 3. The mounting pipe can be clamped to another pipe, or flanged and bolted to the wall or floor. U-bolt clamping secures the assembly to a DN 50 or 2-inch pipe. The U-bolt can be rotated 90° for use with a horizontal pipe.

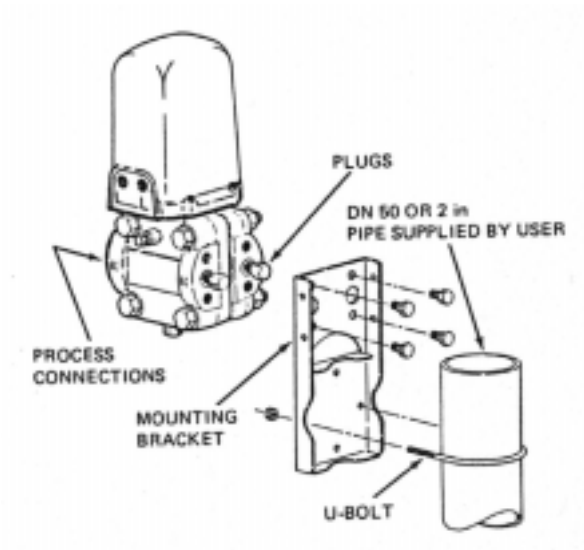

*Figure 3.*

## Air Supply and Transmission Piping

The transmitter must be supplied with clean, dry air at a fixed pressure, within specified limits. Line regulators, filters, and transmission piping should be clean and free from leaks. Refer to Figure 4.

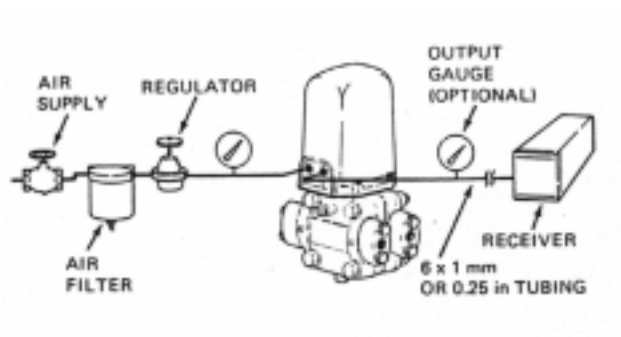

*Figure 4.*



# 2. Liquid Flow Measurement

## Installation

With installations using a horizontal line, the process connections should be made at the **side** of the line to allow trapped vapors to escape from the connecting lines, and to prevent sediment from entering. The transmitter should be mounted **lower** than the process connections.

If the liquid being measured must be isolated from the transmitter, the connecting tubing and the transmitter body must be filled with a suitable seal liquid.

The piping configurations illustrated in Figure 5 and Figure 6 show that the filling tees must be at the same level to maintain an equal head on both sides of the transmitter. This criteria must be met regardless of a nonseal liquid or a seal liquid system.

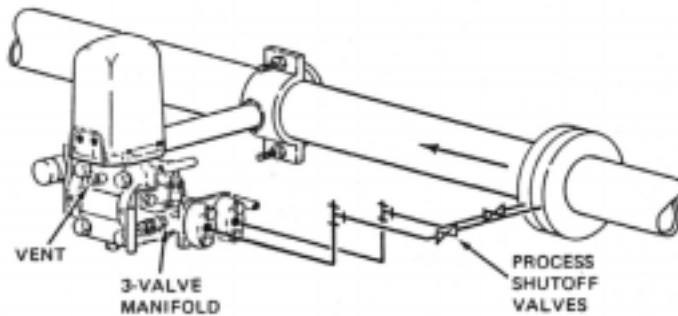

*Figure 5.*

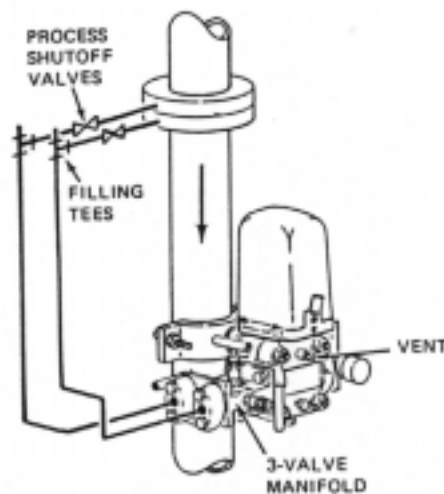

*Figure 6.*

# Operation

## System Fill Using Line Liquid

Refer to Figure 7.

1. Open process shutoff valves.
2. Open high side, low side, and bypass manifold valves.
3. Partially open vents in transmitter body until all air has been forced out of transmitter and lines.
4. Close vents and bypass valve.
5. Check system for leaks.

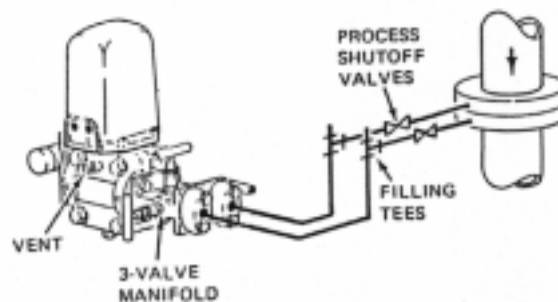

*Figure 7.*

## System Fill Using Seal Liquid

Refer to Figure 8.

1. Close process shutoff valves.
2. Open high side, low side, and bypass manifold valves.
3. Remove plugs from filling tees and pour in seal liquid until both tees overflow.
4. Partially open vents to allow all air to be forced out of the connecting lines and the transmitter body. Close vents.
5. Refill tee connections. Replace plugs and close bypass valve.
6. Check system for leaks.

---

— **⚠ CAUTION** —

To prevent loss of seal liquid and contamination of the transmitter and connecting piping by line liquid, **never** open both high side and low side manifold valves at the same time if bypass valve and process shutoff valves are open.

---

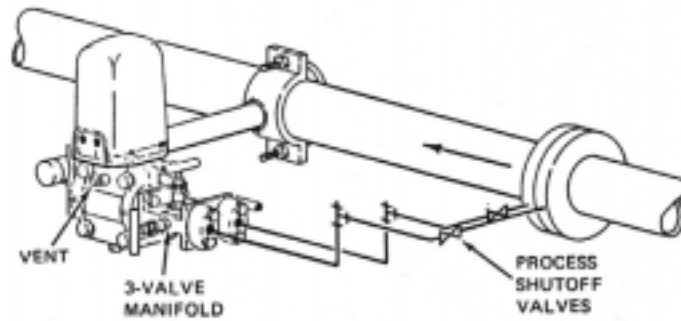
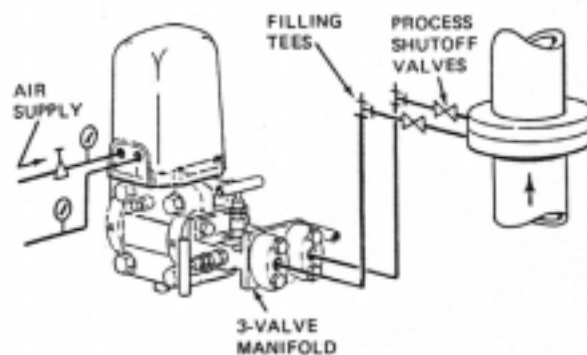

*Figure 8.*

## Transmitter Zero Adjustment

Refer to Figure 9 and Figure 10.

1. Close high side and low side manifold valves.
2. Open bypass valve.
3. Connect a 0 to 140 kPa or 0 to 20 psi test gauge to OUT connection.
4. Adjust air supply to specified pressure.
5. Slightly open high side manifold valve.
6. Adjust ZERO screw so that output pressure reads 20 kPa or 3 psi on test gauge.
7. Reconnect output signal line. If necessary, adjust ZERO adjustment on receiver so that reading will be zero.
8. Return transmitter to normal operation.



*Figure 9.*

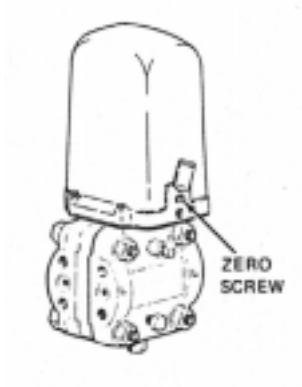

*Figure 10.*

## Putting Transmitter Into Operation

Refer to Figure 9.

1. Check that process connection bolts are tight.
2. Close high and low side manifold valves.
3. Open bypass valve.
4. Open process shutoff valves.
5. Slowly open high side manifold valve.
6. Close bypass valve.
7. Slowly open low side manifold valve.

## Taking Transmitter Out of Operation

1. Close the **low side manifold valve first**.
2. Close high side manifold valve.
3. Open bypass valve.

# 3. Gas Flow Measurement

## Installation

When measuring gas flow, it is of vital importance that moisture be kept out of connecting lines. Except when using a seal liquid, process connections must be made at the **top** of a horizontal flow line, and the transmitter must be mounted **above** the connections. See Figure 11 and Figure 12 for horizontal and vertical lines, respectively.

If the gas being measured must not come in contact with the transmitter, the connecting tubing and the transmitter body must be filled with a suitable seal liquid. The transmitter must be mounted **below** the process connections. See Figure 13.

The piping configuration illustrated in Figure 13 shows that the filling tees must be at the same level to maintain an equal liquid head on both sides of the transmitter.

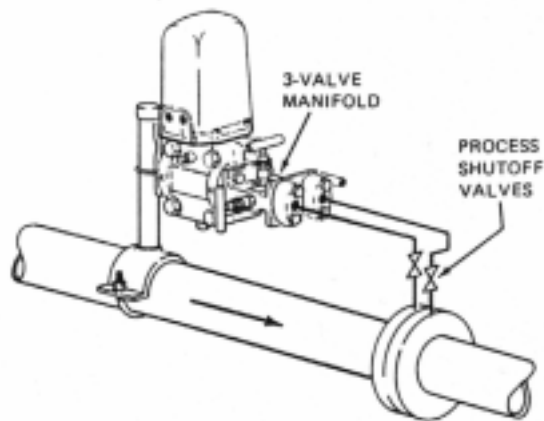

*Figure 11.*

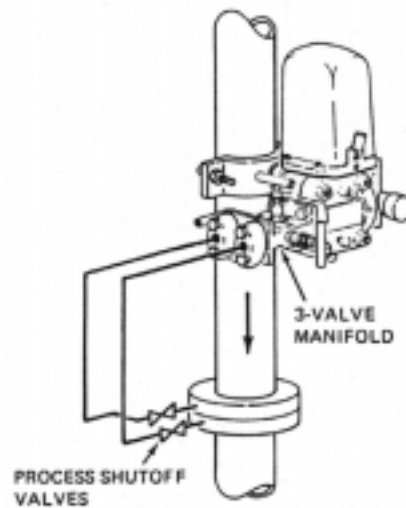

*Figure 12.*

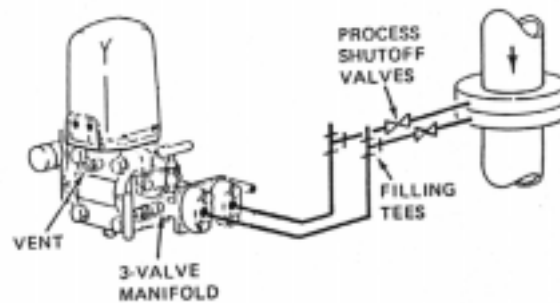

*Figure 13.*

## Operation

### Filling System with Seal Liquid

Refer to Figure 13.

1. Close process shutoff valves.
2. Open high side, low side, and bypass manifold valves.
3. Remove plugs from filling tees and fill to overflowing with seal liquid.
4. Open vents in transmitter body until all air has been forced out of the transmitter and lines. Close vents.
5. Refill tee connections, replace plugs, and close bypass valve.
6. Check lines and fittings for leaks.

---

**—! CAUTION**

To prevent loss of seal liquid and contamination of transmitter and connecting piping by line gas, **never** open both high side and low side manifold valves at the same time if bypass valve and process shutoff valves are open.

---

## Transmitter Zero Adjustment

Refer to Figure 14 and Figure 15.

1. Close high side and low side manifold valves.
2. Open bypass valve.
3. Connect 0 to 140 kPa (0 to 20 psi) test gauge to signal output connection.
4. Adjust air supply to specified pressure.
5. Slightly open high side manifold valve.
6. Adjust ZERO screw until output signal reads 20 kPa (3 psi) on test gauge.
7. Reconnect output signal line. If necessary, adjust **receiver** ZERO adjustment so that reading is zero.
8. Return transmitter to normal operation.

## Putting Transmitter Into Operation

1. Check that process connection bolts are tight.
2. Close high and low side manifold valves.
3. Open bypass valve.
4. Slowly open high side manifold valve.
5. Close bypass valve.
6. Slowly open low side manifold valve.

## Taking Transmitter Out of Operation

1. Close **low side manifold valve first**.
2. Close high side manifold valve.
3. Open bypass valve.

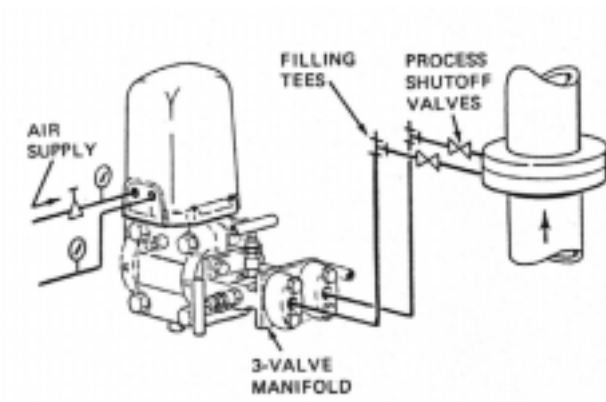

*Figure 14.*

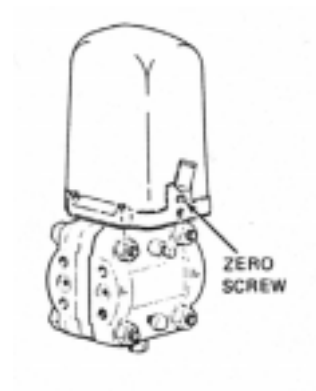

*Figure 15.*



# 4. Steam Flow Measurement

## Installation

In measuring steam flow, the vapor pressures at the primary element are conveyed to the measuring instrument through two equal liquid heads. Condensing chambers are not necessary with the d/p Cell Transmitter. The transmitter has essentially zero displacement and sufficient vapor will condense in the piping to ensure a constant liquid head. It is important, however, to ensure that condensation occurs at the same level in both connection lines, thus preventing error due to unequal liquid columns on the two sides of the instrument.

With horizontal pipeline installations, the process connections should be made at the **side** to allow trapped vapors to escape from the connecting lines, and to prevent sediment from entering these lines. Mount the transmitter **lower** than the process connections. See Figure 16.

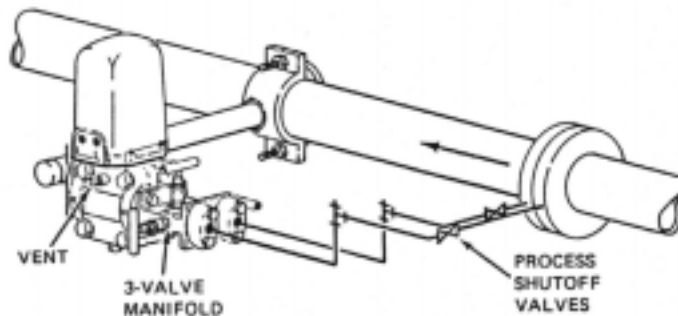

*Figure 16.*

With vertical pipeline installations, a downward flow of steam is recommended, rather than upward. If the flow were upward, any possible condensation build-up or draining of the downstream side of the primary element would affect the measurement. See Figure 17.

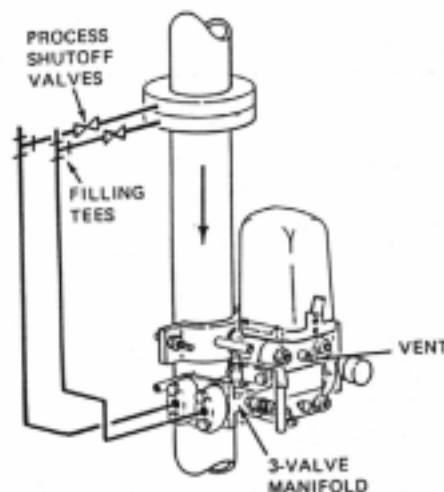

*Figure 17.*

# Operation

## Filling System with Water

Refer to Figure 18.

1. Close process shutoff valves.
2. Open high side, low side, and bypass manifold valves.
3. Remove plugs from filling tees and pour in water until both tees overflow.
4. Partially open vents until **all** air has been forced out of the transmitter body and lines. Close vents.
5. Refill tee connections. Replace plugs and close bypass valve.
6. Check system for leaks.

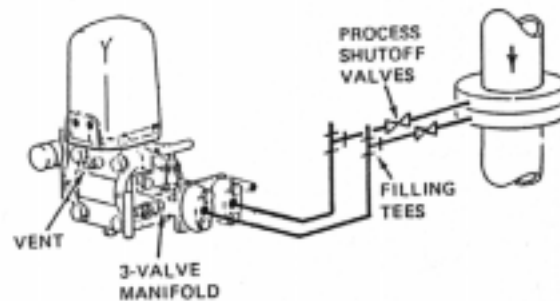
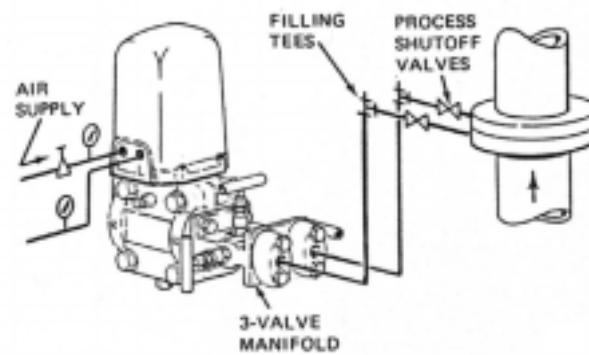

*Figure 18.*

## Zero Adjustment

Refer to Figure 19 and Figure 20.

1. Adjust air supply to specified pressure.
2. Close high side and low side manifold valves.
3. Open bypass valve.
4. Connect 0 to 140 kPa (0 to 20 psi) test gauge to output connection.
5. Slightly open high side manifold valve.
6. Adjust ZERO screw so that output is 20 kPa or 3 psi on the test gauge.
7. Reconnect output signal line. If necessary, change ZERO adjustment on receiver so that the reading is zero.
8. Return transmitter to normal operation.



*Figure 19.*

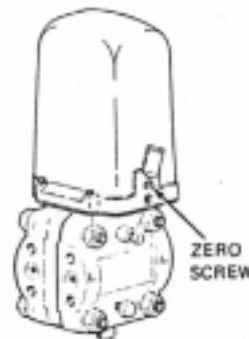

*Figure 20.*

## Putting Transmitter Into Operation

1. Check that process connection bolts are tight.
2. Close high and low side manifold valves.
3. Open bypass valve.
4. Open process shutoff valves.
5. Slowly open high side manifold valve.
6. Close bypass valve.
7. Slowly open low side manifold valve.

## Taking Transmitter Out of Operation

1. Close low side manifold valve first.
2. Close high side manifold valve.
3. Open bypass valve.



# 5. Liquid Level Measurement

## Installation

### Measurement Piping

Connect piping from tank liquid to high pressure (H) side of transmitter.

If the transmitter is to be installed on an **open tank**, install a pipe elbow on vented connector (low pressure) (L) side of transmitter with opening of elbow pointed down to prevent dirt from entering the transmitter.

### Seal Liquid

In installations where the transmitter must be prevented from coming into contact with the tank liquid, the transmitter lines should be filled with a suitable seal liquid. The seal liquid should be heavier than, immiscible with, and must not react chemically with the tank liquid.

If a more positive seal is required, the seal liquid can be pumped into the lines at a minute but definite flow rate and allowed to overflow into the bottom of the tank.

For further seal liquid details, consult Foxboro.

### Reference Leg Details

A reference leg is a convenient device to establish a check point for the transmitter. Refer to Figure 21. Valve R should be located at the height above the tank connection equal to the reference level (usually either the normal or the minimum liquid level in the tank). If the piping between the transmitter and the tank is to be filled with a seal liquid, the height of Valve R must be altered to reflect the ratio of the relative densities (specific gravities) between the two liquids. Use the following formula to determine the actual height of valve R.

$$\text{Actual Height} = (\text{Reference Level}) \frac{\text{Specific Gravity Tank Liquid}}{\text{Specific Gravity of Seal Liquid}}$$

Example:

Reference Level = 20 inches above tank connection

Specific Gravity of Tank Liquid = 0.6

Specific Gravity of Seal Liquid = 0.8

Using formula above:

$$\text{Actual Height} = (20) \frac{0.6}{0.8} = 15 \text{ inches above tank connection}$$

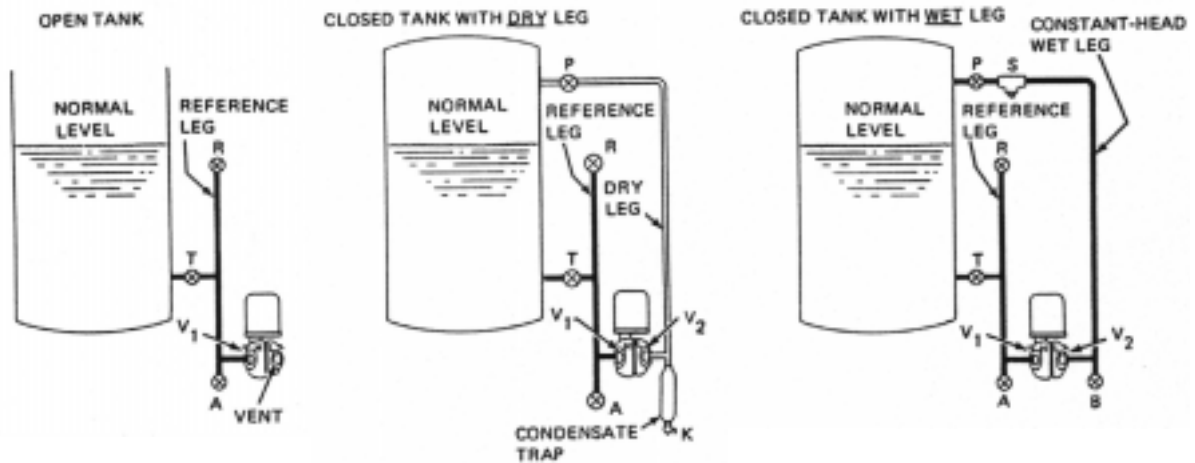

Figure 21.

## Reference Adjustment

Table 1. Procedures for Filling Transmitter Line (see Figure 21)

Open Tank	Closed Tank	
	With Dry Leg	With Wet Leg
Close T; open R and V <sub>1</sub> . Fill line through A.	Close T and open all other valves and vents. Fill line through A.	Close T and P. Open all other valves and vents. Fill all lines through A and B.
Close V <sub>1</sub> and R as liquid starts to come out at these points. Close A.	Close V <sub>1</sub> and R as liquid starts to come out at these points. Close V <sub>2</sub> and K. Close A.	Close V <sub>1</sub> , V <sub>2</sub> , R, and S in sequence as liquid starts to come out at each point. Close A and B.

## Adjustment Procedure

1. Fill transmitter lines using applicable procedure given in Table 1.
2. Adjust air supply to specified pressure.
3. Disconnect line to receiver. Connect a 0 to 140 kPa or 0 to 20 psi test gauge to OUT connection. Refer to Figure 22.
4. Calculate correct output pressure using formula to calculate output at reference level.
5. For transmitter **without** optional zero suppression and zero elevation kit, adjust ZERO screw (Figure 23) until correct output is obtained.

For transmitter **with** optional zero suppression or zero elevation kit, adjust zero-suppression or zero-elevation screw until correct output is obtained. Use ZERO screw for fine adjustments.

6. Remove test gauge and reconnect receiver line. If necessary, change ZERO adjustment on receiver so that reading is correct.

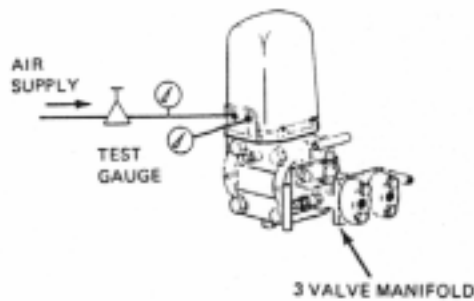

*Figure 22.*

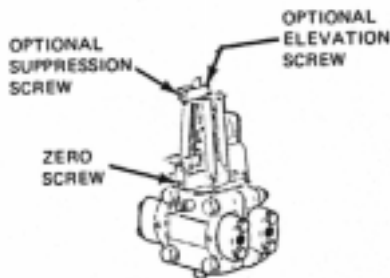

*Figure 23.*

## Formula to Calculate Output at Reference Level

$$\text{Output} = (\text{Span}) \frac{L_R - L_2}{L_1 - L_2} + \text{LRV}$$

Where,

- Span = Output Span, in kPa or psi
- $L_R$  = Reference Level, in  $\text{mH}_2\text{O}$  or  $\text{inH}_2\text{O}$
- $L_2$  = Minimum Level, in  $\text{mH}_2\text{O}$  or  $\text{inH}_2\text{O}$
- $L_1$  = Maximum Level, in  $\text{mH}_2\text{O}$  or  $\text{inH}_2\text{O}$
- LRV = Output Lower Range Value, in kPa or psi

Example,

- Output Range = 3 to 15 psi; therefore,
- Span = 12 psi and LRV = 3 psi.
- $L_R$  = 30  $\text{inH}_2\text{O}$
- $L_2$  = 10  $\text{inH}_2\text{O}$
- $L_1$  = 90  $\text{inH}_2\text{O}$

Solution,

$$\text{Output} = (12) \frac{30 - 10}{90 - 10} + (3) = 6 \text{ psi}$$

---

— **NOTE** —

If seal liquid is used, reference level will be different from actual height of liquid in the reference leg. For details of reference leg with seal liquid, see “Reference Leg Details”.

---



# 6. Calibration Formulas

If the calibrated range of the transmitter is not known, calculate the equivalent head of water at minimum and maximum levels using the applicable formulas and Figure 24 and Figure 25. Calibrate the transmitter using the procedure in Instruction MI 022-340.

To convert metres head of water to kPa, multiply by 9.791. To convert inches head of water to psi, multiply by 0.3606.

## Either Open Tank or Closed Tank with Dry Leg

$$\text{Span} = (x) (G_L)$$

$$H_W \text{ at minimum level} = (z) (G_S) + (y) (G_L)$$

$$H_W \text{ at maximum level} = (z) (G_S) + (x + y) (G_L)$$

Where

$G_L$  = Specific gravity of tank liquid

$G_S$  = Specific gravity of seal liquid

$H_W$  = Equivalent head of water

x, y, and z are shown in Figure 24.

Example:

Open tank with x = 80 inches

y = 5 inches, and z = 10 inches

$G_L = 0.8$

$G_S = 0.9$

$$\text{Span} = (80)(0.8) = 64 \text{ inches}$$

$$H_W \text{ at minimum level} = (10)(0.9) + (5)(0.8) = 13 \text{ inches}$$

$$H_W \text{ at maximum level} = (10)(0.9) + (5 + 80)(0.8) = 77 \text{ inches}$$

Calibrated Range = 13 to 77 inches head of water

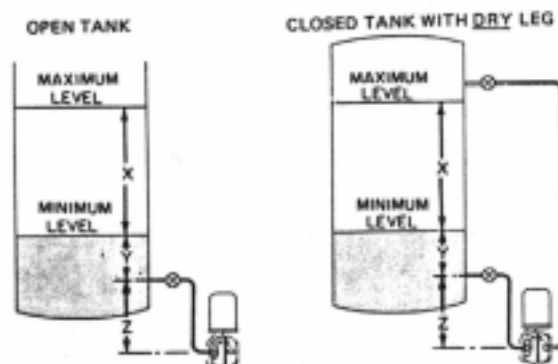

Figure 24.

## Closed Tank With Wet Leg

$$\text{Span} = (x)(G_L)$$

$$H_W \text{ at minimum level} = (y)(G_L) - (d)(G_S)$$

$$H_W \text{ at maximum level} = (x + y)(G_L) - (d)(G_S)$$

Where

$G_L$  = Specific gravity of tank liquid

$G_S$  = Specific gravity of seal liquid

$H_W$  = Equivalent head of water

$x$ ,  $y$ , and  $d$  are shown in Figure 25.

Example:

Closed tank with  $x = 70$  inches

$y = 20$  inches, and  $d = 100$  inches

$G_L = 0.8$

$G_S = 0.9$

Span =  $(70)(0.8) = 56$  inches

$H_W$  at minimum level =  $(20)(0.8) - (100)(0.9) = -74$  inches

$H_W$  at maximum level =  $(70 + 20)(0.8) - (100)(0.9) = -18$  inches

Calibrated Range = -74 to -18 inches head of water

(Minus signs indicate that the higher pressure is applied to the low pressure side of the transmitter.)

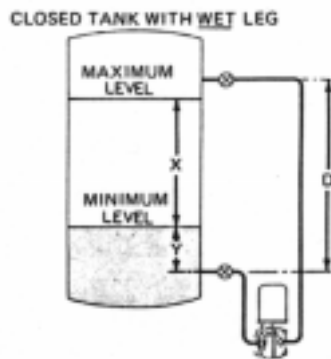

*Figure 25.*

### ISSUE DATES

FEB 1986

APR 1999

Vertical lines to right of text or illustrations indicate areas changed at last issue date.

### The Foxboro Company

33 Commercial Street  
Foxboro, MA 02035-2099  
United States of America  
<http://www.foxboro.com>  
Inside U.S.: 1-888-FOXBORO  
(1-888-369-2676)

Outside U.S.: Contact your  
local Foxboro Representative.  
Facsimile: (508) 549-4492

**A Siebe Group Company**

Foxboro and d/p Cell are registered trademarks of The Foxboro Company.  
Siebe is a registered trademark of Siebe, plc.

Copyright 1986 - 1999 by The Foxboro Company  
All rights reserved

MB 100

Printed in U.S.A

0499