

Universal Instruction Manual

**I/A Series® Pressure Transmitters
Models IAP10, IAP20,
IGP10, IGP20, IGP25 and IGP50,
IDP10, IDP25, IDP50**

Configuration, Calibration, Installation, and Operation

Safety information in many languages is available on our website. For help downloading this information, contact our Global Customer Support Center.

Contents

Figures.....	vii
Tables.....	ix
Preface.....	xi
1. Safety Information	1
Transmitter Identification	1
Supply Voltage	1
Electrical Certification Rating	2
PED Certification	2
Pressure Rating	2
Pressure Seal PSFLT	3
Pressure Seals PSFPS and PSFES	4
Pressure Seals PSFAR and PSFAD	5
Pressure Seals PSTAR and PSTAD	5
Pressure Seals PSISR and PSISD	6
Pressure Seals PSSCR and PSSCT	6
PSSSR and PSSST (Sanitary Tank Spud) Seals	6
Origin Code	6
Operating Temperature Limits	6
Process Wetted Materials	10
Pressure Seals PSFLT, PSFPS, and PSFES	10
Pressure Seals PSFAR, PSFAD, PSTAR, PSTAD, PSISR, and PSISD	10
Pressure Seals PSSCR	12
Pressure Seals PSSCT	12
Pressure Seals PSSSR and PSSST	12
Warnings	12
General Warning	12
ATEX Warnings	13
Explosionproof/Flameproof and Enclosure Warning	13
Intrinsically Safe and Type n Warning	14
Type n Warning	14
Pressure Warnings	14
Process Fluid Warning	16
Seal or Sensor Fill Fluid Warning	16
Parts Replacement Warning	16
EC Declaration of Conformity	17
2. Installation	19
Mechanical Installation	19
Differential Pressure Transmitter	19
Process-Mounted Transmitter	20
Manifold Mounted Transmitter	20

Pipe- or Surface-Mounted Transmitter	22
Venting and Draining	27
Installation of Flow Measurement Piping	28
Filling System with Seal Liquid	30
Absolute and Gauge Pressure Transmitter	31
IAP10, IGP10, IGP25 and IGP50 Transmitters	31
IAP20 and IGP20 Transmitters	32
Typical Transmitter Piping	33
Transmitter with Seals	34
Positioning the Housing	35
Positioning the Display	35
Setting the Write Protect Jumper	35
Cover Locks	36
Wiring	36
4 to 20 mA Output Signal (Model Codes -A, -D, and -T)	37
HART Multidrop Wiring (Model Code -T)	41
1 to 5 V dc Output Signal (Model Code -V)	42
Power Supply Voltage and Current	42
Output Load	42
Three or Four Wire Connections	42
FoxCom Communications Protocol (Model Code -D)	45
Foundation Fieldbus Communication (Model Code -F)	47
Installing Fieldbus Software (Model Code -F)	49
Putting a Differential Pressure Xmtr Into Operation	50
Taking a Differential Pressure Xmtr Out of Operation	50
3. Operation Using Local Display	51
Moving Through the Menu Structure	53
Entering Numerical Values	53
Zeroing from the LCD Indicator Pushbuttons or Optional External Zero Button	54
Zeroing from a HART Communicator	55
4. Calibration	57
Calibration Diagram	57
Liquid Level Application Calibrated Range Values	58
Method #1 - Calculating the range values	61
Method #2 - Using the Transmitters to Determine the Range Values	61
Method #3 - Getting the Local Indicator and Transmitted Value to Indicate Level - HART Transmitters	62
Method #4 - Getting the Local Indicator and Transmitted Value to Indicate Level - Analog Output Transmitters	63
5. Configuration Diagrams.....	65
FoxCom Communications (Code -D)	65
HART Communications (Code -T)	68

Foundation Fieldbus Communications (Code -F)	71
4 to 20 mA (Code -A) and 1 to 5 V dc (Code -V)	72
Index	73

Figures

1	Sample Transmitter Identification	1
2	Sample Seal Data Plate	2
3	Pressure Connections	14
4	Sensor Replacement	15
5	Sensor Replacement (pvdf Inserts)	15
6	Typical Mounting of an IDP Transmitter Supported by Process Piping	20
7	Typical Mounting of an IDP Transmitter Supported by a Bypass Manifold	20
8	Typical Mounting of M4A and M4T Manifold with -AM Bracket	21
9	Typical Mounting of MB3 Manifold with -AM Bracket	21
10	Typical Mounting of IMV25 Transmitter on Coplanar%o Manifold	22
11	Pipe or Surface Mounted Transmitter Using a Standard Bracket	23
12	Examples of Mounting With a Standard Bracket	23
13	Details of a Universal Bracket	24
14	Mounting a Transmitter with Traditional Structure Using a Universal Bracket	25
15	Vertical Pipe Mounting a Transmitter with LP2 Structure Using a Universal Bracket ..	25
16	Horizontal Mounting a Transmitter with LP2 Structure Using a Universal Bracket	26
17	Vertical Mounting - Cavity Draining	27
18	Vertical Mounting - Cavity Venting	27
19	Horizontal Mounting - Cavity Venting	27
20	Vertical Mounting - Cavity Venting	28
21	Horizontal Mounting - Cavity Venting and Draining	28
22	Cavity Venting and Draining	28
23	Example of Horizontal Process Line Installation	29
24	Example of Vertical Process Line Installation	30
25	IAP10, IGP10, IGP25, and IGP50 Transmitter Mounting	31
26	IAP20 and IGP20 Transmitter Mounting	32
27	Typical Transmitter Piping (IGP10 shown)	33
28	Hot Process Piping	34
29	Housing Screw or Clip Location	35
30	Accessing Field Terminals	36
31	Identification of Field Terminals	37
32	Supply Voltage and Loop Load	38
33	Loop Wiring 4 to 20 mA Output Transmitters	40
34	Wiring Several 4 to 20 mA Transmitters to a Common Power Supply	40
35	Typical Multidrop Network	41
36	Identification of Field Terminals	42
37	Three-wire Connection	43
38	Four-wire Connection	43
39	Loop Wiring (four-wire connection shown)	44
40	Wiring Several Transmitters to a Common Power Supply	45
41	Typical Transmitter Wiring to an I/A Series System	46
42	Wiring Diagram of Typical FOUNDATION Fieldbus Transmitter Installation	48
43	Local Display Module	52

44	Top Level Structure Diagram	52
45	Typical Menu Structure	53
46	Calibration Structure Diagram	57
47	Calibration Structure Diagram (Continued)	58
48	Transmitter Connected to Open Tank	59
49	Transmitter Connected to Closed Tank with Dry Leg	59
50	Transmitter Connected to Closed Tank with Wet Leg	60
51	Transmitter Connected to Closed Tank With Dual Seals	60
52	FoxCom Configuration Structure Diagram	65
53	FoxCom Configuration Structure Diagram (Continued)	66
54	FoxCom Configuration Structure Diagram (Continued)	67
55	Configuration Structure Diagram	68
56	Configuration Structure Diagram (Continued)	69
57	Configuration Structure Diagram (Continued)	70
58	Configuration Structure Diagram (Code -A and -V)	72

Tables

1	Pressure Seal PSFLT Pressure Limits	3
2	Pressure Seal PSFPS and PSFES Pressure Limits	4
3	Pressure Seals PSFAR and PSFAD Pressure Limits	5
4	Pressure Seals PSTAR and PSTAD Pressure Limits	5
5	Interpretation of Model Code for IDP10, IAP20, IGP20, IDP25, and IDP50 Transmitters	6
6	Interpretation of Model Code for IAP10, IGP10, IGP25, and IGP50 Transmitters	8
7	Sensor Body Operating Temperature Limits for Models Listed in Tables 5 and 6	9
8	Seal Fill Fluid and Operating Temperature Limits	10
9	Pressure Seal PSFLT, PSFPS, and PSFES Wetted Materials	10
10	Pressure Seal Lower Housing Materials	10
11	Pressure Seal Diaphragm Materials	11
12	Pressure Seal Gasket Materials	11
13	Pressure Seal PSSCR Diaphragm Materials	12
14	Capillary Fill Fluid Specific Gravities	34
15	Minimum Supply Voltage Requirements	47

Preface

This Universal Instruction Manual is designed to provide the user with a single, concise, easy-to-use manual that covers the key points needed for configuration, calibration, installation, and operation of I/A Series Pressure Transmitters.

It covers all models of single variable pressure transmitters in the I/A Series family, including absolute, gauge, and differential pressure transmitters, with FoxCom, HART, FOUNDATION fieldbus, or analog output electronics.

This universal manual, along with a CD containing detailed information, is provided free of charge with every I/A Series Pressure Transmitter, unless the purchaser requests that these two items be omitted.

For additional detailed information about each model, including dimensional prints, parts lists, and more detailed instructions, please refer to the standard CD supplied or the optional paper instruction book that is available from Invensys for each model in the line.

- ◆ Standard Documentation Shipped with every I/A Series Pressure Transmitter
 - ◆ A brief “Getting Started” Pocket-Sized Bulletin
 - ◆ This Universal Instruction Manual
 - ◆ A CD that contains the complete documentation set for I/A Series Pressure Transmitters
- ◆ When Optional Feature K1 is specified in the Model Code when the transmitter is ordered:

A brief “Getting Started” Pocket-Sized Bulletin only is supplied

Optional Feature K1 is offered for those users who want Invensys to omit the documentation shipped with every transmitter. This may be specified when multiple identical transmitters are ordered and the user does not want multiple sets of documentation.

1. Safety Information

Transmitter Identification

A typical data plate is shown in Figure 1.

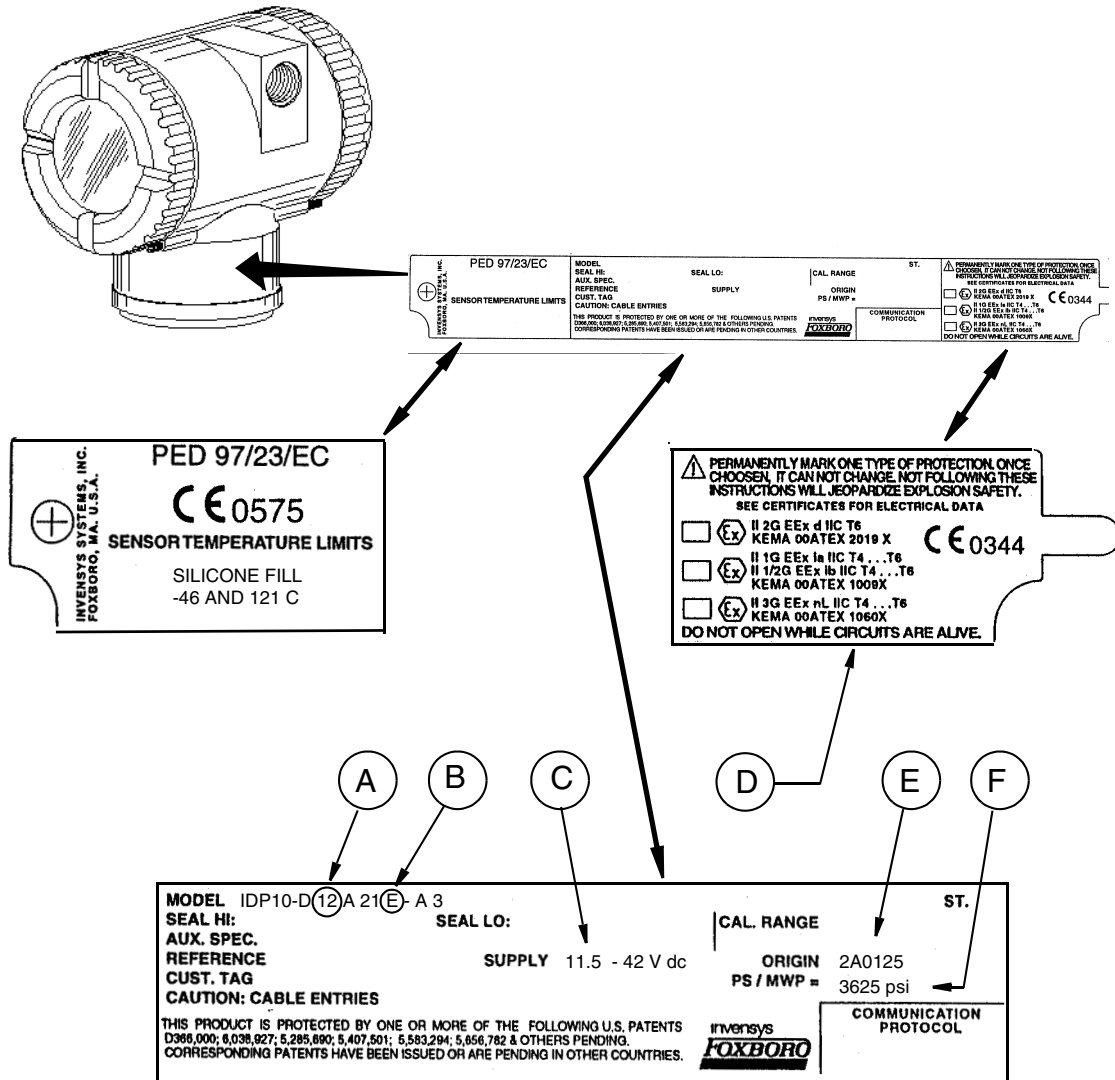

Figure 1. Sample Transmitter Identification

Review the model code on the data plate attached to your transmitter to determine its electrical, pressure, and hazardous location ratings.

Supply Voltage

The proper supply voltage is printed on the data plate. See Item C on the example shown in Figure 1. Ensure that the proper electrical source is connected to the transmitter.

Electrical Certification Rating

The electrical safety design code is printed on the data plate as part of the model code. See Item B on the example shown in Figure 1. See the "Product Safety Specifications" section of the instruction pertaining to your instrument on the enclosed CD-ROM to identify this code. The type of protection is also marked on the data plate. See Item D on the example shown in Figure 1.

PED Certification

Invensys offers the PED (Harmonized Pressure Equipment Directive for the European Community) certification only with transmitters ordered with ATEX Electrical Safety Design Code selections. Transmitters with PED certification have a CE marking on the data plate that also carries the PED number 0575.

Pressure Rating

The maximum working pressure (PS or MWP) for the transmitter is printed on the data plate. See Item F on the example shown in Figure 1.

The data plate of flanged level transmitters and transmitters with flanged pressure seals are stamped with the MWP **if the transmitter pressure range is the limiting factor**. It is stamped "Flange Rate" **if the flange rating is the limiting factor**. The MWP of the flanged seal is stamped on the seal data plate. See Figure 2.

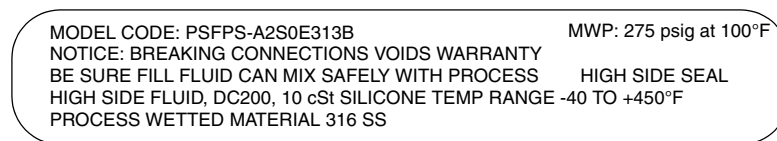

Figure 2. Sample Seal Data Plate

When using transmitters with threaded, in-line saddle weld, or sanitary pressure seals, compare the MWP of the transmitter on the transmitter data plate and the MWP of the seals on the seals data plates and **use the lesser value as the system MWP**.

The MWP on the seal data plates may not be given at your process temperature. Use the following information and industry standards as required to determine the actual pressure limits for your application.

Pressure Seal PSFLT

Table 1. Pressure Seal PSFLT Pressure Limits

Process Connections Flange	Process Temperature ^(c)	Maximum Working Pressure	
		Carbon Steel ^(d)	316L Stainless Steel ^(e)
ANSI Class 150 ^(a)	100°F	285 psig	275 psig
	200°F	260 psig	240 psig
	300°F	230 psig	215 psig
	450°F	185 psig	183 psig
ANSI Class 300 ^(a)	100°F	740 psig	720 psig
	200°F	675 psig	620 psig
	300°F	655 psig	560 psig
	450°F	618 psig	498 psig
ANSI Class 600 ^(a)	100°F	1480 psig	1440 psig
	200°F	1350 psig	1240 psig
	300°F	1315 psig	1120 psig
	450°F	1235 psig	993 psig
DIN PN 10/16 ^(b)	50°C	16 bar	16 bar
	100°C	16 bar	16 bar
	150°C	14.5 bar	14 bar
	250°C	11 bar	10.5 bar
DIN PN 10/40 and PN 25/40 ^(b)	50°C	40 bar	40 bar
	100°C	40 bar	35 bar
	150°C	37.5 bar	33.5 bar
	250°C	32 bar	30 bar

(a)ANSI flanges per ASME/ANSI B16.5-1988

(b)DIN flanges per BS4504.

(c)Flange temperature/pressure ratings only; seal temperature ratings may be lower; refer to Table 8.

(d)ASME/ANSI Material Group 1.1; linear interpolation acceptable.

(e)ASME/ANSI Material Group 2.2; linear interpolation acceptable.

Pressure Seals PSFPS and PSFES

Table 2. Pressure Seal PSFPS and PSFES Pressure Limits

Process Connection Flange	Process Temperature ^(c)	Maximum Working Pressure	
		Carbon Steel ^(d)	316L Stainless Steel ^(e)
ANSI Class 150 ^(a)	100°F	285 psig	275 psig
	200°F	230 psig	240 psig
	400°F	200 psig	195 psig
	500°F	170 psig	170 psig
	600°F	140 psig	140 psig
ANSI Class 300 ^(a)	100°F	740 psig	720 psig
	200°F	675 psig	620 psig
	400°F	635 psig	515 psig
	500°F	600 psig	480 psig
	600°F	550 psig	450 psig
ANSI Class 600 ^(a)	100°F	1480 psig	1440 psig
	200°F	1350 psig	1240 psig
	400°F	1270 psig	1030 psig
	500°F	1200 psig	955 psig
	600°F	1095 psig	905 psig
DIN PN 10/16 ^(b)	50°C	16 bar	16 bar
	100°C	16 bar	16 bar
	150°C	14.5 bar	14 bar
	200°C	13 bar	12 bar
	300°C	9 bar	9 bar
DIN PN 10/40 and PN 25/40 ^(b)	50°C	40 bar	40 bar
	100°C	40 bar	35 bar
	150°C	37.5 bar	33.5 bar
	200°C	35 bar	32 bar
	300°C	28 bar	28 bar

(a)ANSI flanges per ASME/ANSI B16.5-1988

(b)DIN flanges per BS4504.

(c)Flange temperature/pressure ratings only; seal temperature ratings may be lower; refer to Table 8.

(d)ASME/ANSI Material Group 1.1; linear interpolation acceptable.

(e)ASME/ANSI Material Group 2.2; linear interpolation acceptable.

Pressure Seals PSISR and PSISD

The maximum working pressure is equivalent to a nominal 3- or 4-inch Schedule 40 pipe as defined by ASME/ANSI standards.

Pressure Seals PSSCR and PSSCT

The maximum working pressure of the seal process connection varies with the clamping device used. Refer to Tri-Clover Tri-Clamp standards to determine the pressure limits of the clamping system that you are using.

PSSSR and PSSST (Sanitary Tank Spud) Seals

The maximum working pressure of mini tank spud seal is 1.55 MPa at 120°C (225 psi at 250°F). That of the standard tank spud seal is 1.38 MPa at 120°C (200 psi at 250°F).

Origin Code

The origin code identifies the area of manufacture and the year and week of manufacture. See Item E on the example shown in Figure 1. In the example, 2A means the product was manufactured in the Measurement and Instrument Division, 01 identifies the year of manufacture as 2001, and 25, the week of manufacture in that year.

Operating Temperature Limits

The operating temperature limits of the electronics are -40°C and +85°C (-40°F and +185°F). The limits are -40°C and +75°C (-40°F and +167°F) for IAP10, IGP10, IGP25, and IGP50 Transmitters with ATEX flameproof certification. Ensure that the transmitter is operated within this range.

The sensor body operating temperature limits are determined by the sensor fill fluid. The cover material, sensor diaphragm material and fill fluid are specified by two characters in the model code on the data plate. See Item A on the example shown in Figure 1. Also see Table 5 and Table 6 to interpret this part of the code and Table 7 to determine the sensor body temperature limits. In the example IDP10-D12A21E-A3, the number 12 identifies the fill fluid in Table 5 as silicone. Table 7 identifies silicone as having temperature limits of -46 and +121°C (-50 and +250°F).

Table 5. Interpretation of Model Code for IDP10, IAP20, IGP20, IDP25, and IDP50 Transmitters

Code	Cover Material	Sensor Diaphragm Material	Fill Fluid
10	Steel	Co-Ni-Cr	Silicone
11	Steel	Co-Ni-Cr	Fluorinert
12	Steel	316 ss	Silicone
13	Steel	316 ss	Fluorinert
16	Steel	Hastelloy C	Silicone
17	Steel	Hastelloy C	Fluorinert

Table 5. Interpretation of Model Code for IDP10, IAP20, IGP20, IDP25, and IDP50 Transmitters (Continued)

Code	Cover Material	Sensor Diaphragm Material	Fill Fluid
20	316 ss	Co-Ni-Cr	Silicone
21	316 ss	Co-Ni-Cr	Fluorinert
22	316 ss	316 ss	Silicone
23	316 ss	316 ss	Fluorinert
2G	316 ss	316 ss, gold-plated	Silicone
24	316 ss	Monel	Silicone
25	316 ss	Monel	Fluorinert
26	316 ss	Hastelloy C	Silicone
27	316 ss	Hastelloy C	Fluorinert
34	Monel	Monel	Silicone
35	Monel	Monel	Fluorinert
46	Hastelloy C	Hastelloy C	Silicone
47	Hastelloy C	Hastelloy C	Fluorinert
48	Hastelloy C	Tantalum	Silicone
49	Hastelloy C	Tantalum	Fluorinert
78	pvdF Insert	Tantalum	Silicone
79	pvdF Insert	Tantalum	Fluorinert
F1	N/A - Used with pressure seal		Silicone
F2			Fluorinert
F3			Silicone
F4			Fluorinert
S1			Silicone
S2			Fluorinert
S3			Silicone
S4			Fluorinert
S5			Silicone
S6			Fluorinert
SA			Silicone
SB			Inert
SC			Silicone
SD			Inert
SE			Silicone
SF			Inert

Table 6. Interpretation of Model Code for IAP10, IGP10, IGP25, and IGP50 Transmitters

Code	Process Connector Material	Sensor Diaphragm Material	Fill Fluid
20	316L ss	Co-Ni-Cr	Silicone
21	316L ss	Co-Ni-Cr	Fluorinert
22	316L ss	316L ss	Silicone
23	316L ss	316L ss	Fluorinert
24	15-5 ss	15-5	None
26	Inconel X-750	Inconel X-750	None
28	13-8Mo ss	13-8Mo ss	None
30	316L ss	Hastelloy C	Silicone
31	316L ss	Hastelloy C	Fluorinert
32	Hastelloy C	Hastelloy C	Silicone
33	Hastelloy C	Hastelloy C	Fluorinert
TA	316L ss	316L ss	Neobee
T2	316L ss	316L ss	Neobee
T3	316L ss	316L ss	Neobee
TB	316L ss	Hastelloy C	Neobee
T4	316L ss	Hastelloy C	Neobee
T5	316L ss	Hastelloy C	Neobee
M1	316L ss	316L ss	Neobee
M6	316L ss	316L ss	Neobee
M9	316L ss	316L ss	Neobee
PX	316L ss	316L ss	Neobee
PZ	316L ss	316L ss	Neobee
PA	316L ss	316L ss	Silicone
PB	316L ss	316L ss	Silicone
PC	316L ss	316L ss	Silicone
PD	316L ss	316L ss	Silicone
PE	316L ss	Hastelloy C	Silicone
PF	316L ss	Hastelloy C	Silicone
PG	316L ss	Hastelloy C	Silicone
PH	316L ss	Hastelloy C	Silicone
PJ	316L ss	Hastelloy C	Silicone
D1	N/A - Used with pressure seal		Silicone
D2			Fluorinert
S3			Silicone
S4			Fluorinert
SC			Silicone
SD			Inert

Table 7. Sensor Body Operating Temperature Limits for Models Listed in Tables 5 and 6

Limiting Factor	Temperature Limits
Silicone Fill Fluid	-46 and +121°C (-50 and +250°F)
Fluorinert Fill Fluid	-29 and +121°C (-20 and +250°F)
Neobee Fill Fluid	-18 and +204°C (0 and 400°F) ^{(a) (b)}
pvdf Inserts	-7 and +82°C (20 and 180°F)

(a) At process connection

(b) PSSSR, PSSST, IGP10, IAP10, IGP25-.M with the EPDM O ring supplied are limited to a maximum temperature of 121°C (250°F).

For transmitters with pressure seals, the temperature limits at the seals are shown in Table 8. The pressure seal fill fluid code is found in the pressure seal model code as shown in the following examples (fill fluid code position is underlined and bolded):

PSFLT	PSFLT-B2S015 <u>3</u>
PSFPS and PSFES	PSFPS-A2S013 <u>3</u> 4E
PSFAR	PSFAD-D232SSS2SBC <u>1</u> 3M
PSFAD	PSFAD-D232SSS2SBC <u>1</u>
PSTAR	PSTAR-B32USSS1BCC <u>3</u> 4F
PSTAD	PSTAR-B32USSS1BCC <u>3</u>
PSISR	PSISR-A23JSSS1SC <u>1</u> 4M
PSISD	PSISD-A23JSSS1SC <u>1</u>
PSSCR	PSSCR-D21S3 <u>5</u> 4H
PSSCT	PSSCT-B21S <u>5</u> 5
PSSSR	PSSSR-B4S23 <u>5</u> 4H
PSSST	PSSST-B4S2 <u>5</u> 5

Table 8. Seal Fill Fluid and Operating Temperature Limits

Code	Fill Fluid	Temperature Limits	
		Direct Connected ^(a,b) PSFLT, PSFAD, PSTAD, PSISD, PSSCT, PSSST	Remote Connected ^(b) PSFPS, PSFES, PSFAR, PSTAR, PSISR, PSSCR, PSSSR
1	DC200, 10cS, Silicone	-40 and +204°C (-40 and +400°F)	-40 and +232°C (-40 and +450°F)
2	FC77 Fluorinert	-59 and +82°C (-75 and +180°F)	-59 and +82°C (-75 and +180°F)
3	DC200, 3cS, Silicone	-40 and +149°C (-40 and +300°F)	-40 and +149°C (-40 and +300°F)
4	DC704 (HTF) Silicone	0 and +204°C (32 and 400°F)	0 and +304°C (32 and 580°F)
5	Neobee ^(c)	-18 and +204°C (0 and 400°F)	-18 and +204°C (0 and 400°F) ^(c)

(a) Limited to 204°C (400°F) maximum regardless of fill fluid due to transmitter maximum temperature limits.

(b) PSFAR, PSFAD, PSTAR, PSTAD, PSISR, and PSISD seals with pte gaskets are limited to 60°C (140°F).

(c) PSSSR, PSSST, IGP10, IAP10, IGP25-.M with the EPDM O ring are limited to a maximum temperature of 121°C (250°F).

Process Wetted Materials

Refer to Table 5 to determine if the process cover and sensor diaphragm material are suitable for the process. For transmitters with pressure seals, the seal wetted material is as follows:

Pressure Seals PSFLT, PSFPS, and PSFES

Table 9. Pressure Seal PSFLT, PSFPS, and PSFES Wetted Materials

Material Code	Material
S	316L ss
C	Hastelloy C
T	Tantalum

The process wetted material code is found in the pressure seal model number which is located on the pressure seal. See following example:

PSFLT-B2S0153
└─ SEAL WETTED MATERIAL

Pressure Seals PSFAR, PSFAD, PSTAR, PSTAD, PSISR, and PSISD

Table 10. Pressure Seal Lower Housing Materials

Material Code	Material
S	316 ss
K	Carbon Steel
C	Hastelloy C
T	Tantalum Plate
E	Titanium Grade 4

Table 10. Pressure Seal Lower Housing Materials

Material Code	Material
L	Inconel 600
M	Monel 400
N	Nickel 200
G	Glass Filled ptfe
P	Polyvinyl Chloride

Table 11. Pressure Seal Diaphragm Materials

Material Code	Material
S	316L ss
C	Hastelloy C276
T	Tantalum
E	Titanium Grade 2
L	Inconel 600
M	Monel 400
N	Nickel 200

Table 12. Pressure Seal Gasket Materials

Material Code	Material
S	Organic Fiber with Nitrile Binder
3	Silver Plated 316 ss
T	ptfe
B	Buna N
V	Viton
G	Grafoil
T	Silver Plated Hastelloy C

The material codes are found in the pressure seal model number which is located on the pressure seal. See following example:

PSFAR-D232SSS1SA0

S — GASKET MATERIAL
 3 — DIAPHRAGM MATERIAL
 T — LOWER HOUSING MATERIAL

Pressure Seals PSSCR

Table 13. Pressure Seal PSSCR Diaphragm Materials

Material Code	Material
S	316L ss
C	Hastelloy C276

The diaphragm material code is found in the pressure seal model number which is located on the pressure seal. See following example:

PSSCR-D21S354H
 └ DIAPHRAGM MATERIAL

The housing material is 316 ss.

The gasket is provided by the user.

Pressure Seals PSSCT

The housing material is 316 ss.

The diaphragm material is 316L ss.

The gasket is provided by the user.

Pressure Seals PSSSR and PSSST

The housing material is 316 ss.

The diaphragm material is 316L ss.

The gasket material is EPDM.

Warnings

General Warning

WARNING

1. Transmitters must be installed to meet all applicable local installation regulations, such as hazardous location requirements, electrical wiring codes, and mechanical piping codes. Persons involved in the installation must be trained in these code requirements to ensure that the installation takes maximum advantage of the safety features designed into the transmitter.
 2. A plug is supplied with each transmitter with 1/2 NPT conduit connection. It is intended to provide moisture ingress protection of the unused housing conduit entry. The plug must be wrench tight to achieve this level of protection. Thread sealant is required. Explosion-proof applications may require a certified plug. Housings with M20 / PG 13.5 threaded conduit connections are provided with an ATEX certified plug. Thread sealant is required to provide moisture ingress protection.
-

ATEX Warnings

— **WARNING**

Apparatus marked as Category 1 equipment and used in hazardous areas requiring this category must be installed in such a way that, even in the event of rare incidents, the versions with an aluminum alloy enclosure can not be an ignition source due to impact and friction.

— **WARNING**

Install ATEX certified transmitters in accordance with the requirements of standard EN 60079-14.

— **WARNING**

To install a transmitter labeled with multiple approvals, select and permanently mark the certification label in the tick block to distinguish the installed approval type from the unused approval types. Once installed, the transmitter **cannot** be reinstalled using any other approval type. Not following these instructions will jeopardize explosion safety.

On IGPxx and IAPxx Transmitters with IECEx certification, the maximum constructional gap (I_C) is less than that required by IEC 60079-1:2003 as detailed in the table below:

Flamepath	Maximum Gap (mm)
Transducer / Plug Low	0.04
Lid / Window Spigot (flat part)	0.04

Explosionproof/Flameproof and Enclosure Warning

— **WARNING**

1. To prevent possible explosion and to maintain explosionproof/flameproof and dust-ignitionproof protection, plug unused openings with a certified metal pipe plug. For 1/2 NPT connections, both the plug and conduit must be engaged a minimum of five full threads. For M20 and PG 13.5 connections, the certified plug provided and the conduit must be engaged a minimum of seven full threads.
 2. The threaded housing covers must be installed. Turn covers to seat O-ring into the housing and then continue to hand tighten until the cover contacts the housing metal-to-metal.
 3. If the electronics housing is removed for any reason, it must be hand tightened fully. Then engage the set screw until it bottoms out and **back it off 1/8th turn**. Fill the set screw recess with red lacquer (Foxboro Part Number X0180GS or equivalent). The housing then may be rotated up to one full turn in a counterclockwise direction for optimum access to adjustments.
-

Intrinsically Safe and Type n Warning

— **! WARNING** —

Since Invensys does not specify live maintenance, to prevent ignition of flammable atmospheres, disconnect power before servicing unless the area is certified to be nonhazardous.

Type n Warning

— **! WARNING** —

On transmitters certified for ATEX protection n, CSA Class I, Division 2, or FM nonincendive for Class I, Division 2, the threaded housing covers must be installed.

Pressure Warnings

— **! WARNING** —

When installing your transmitter, tighten process connector bolts to a torque of 61 N•m (45 ft•lb) and drain plugs and optional vent screws to 20 N•m (15 ft•lb). See Figure 3.

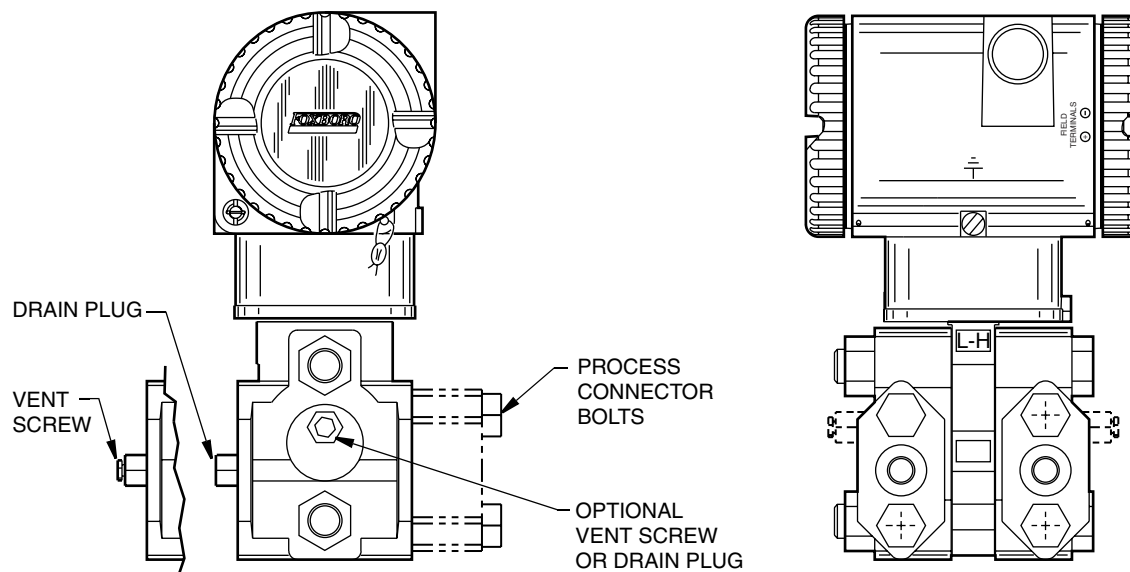

Figure 3. Pressure Connections

— **! WARNING** —

If a sensor is replaced or process covers are rotated for venting, replace the gaskets and torque cover bolts (see Figures 4 and 5) to 100 N•m (75 ft•lb) in several even increments. Torque values are 66 N•m (50 ft•lb) when optional 316 ss bolts are specified (option B1). A pressure test is required. Perform a hydrostatic test with a liquid following proper hydrostatic test procedures. Pressure test the process cover

assembly by applying a hydrostatic pressure of 150% of the maximum static and overrange pressure rating to both sides of the process cover/sensor assembly simultaneously through the process connections. Hold pressure for one minute. There should be no leakage of the test fluid through the gaskets.

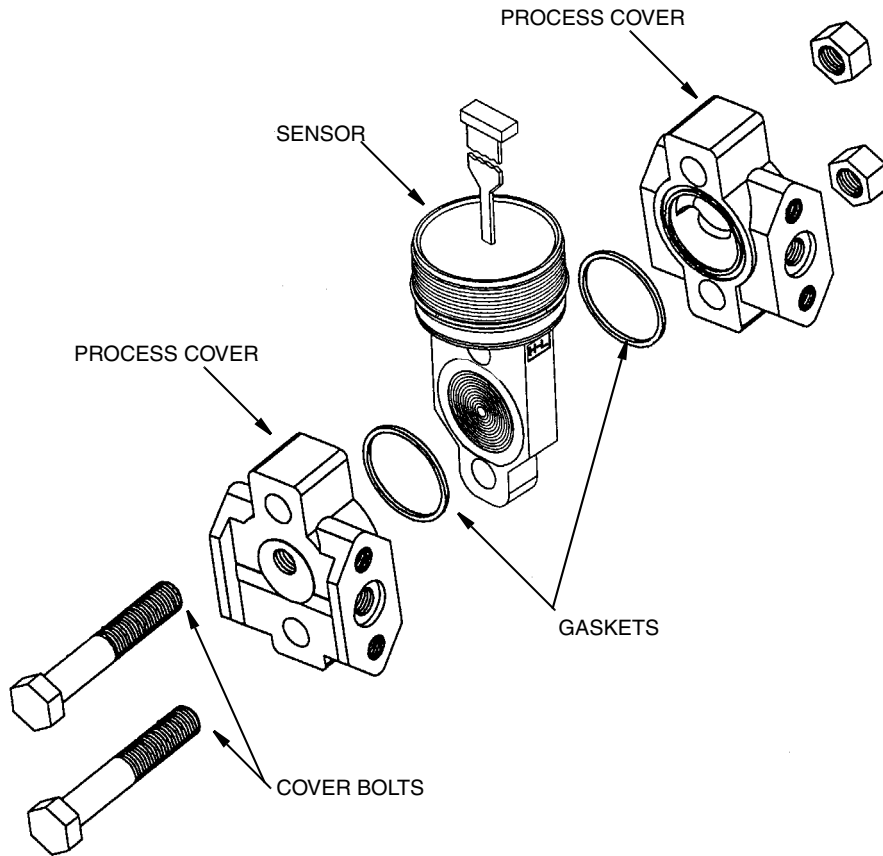

Figure 4. Sensor Replacement

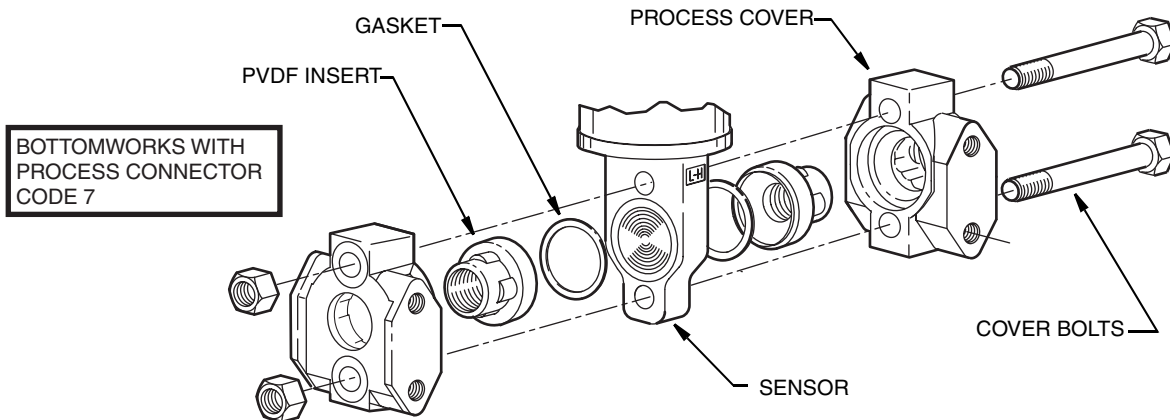

Figure 5. Sensor Replacement (pvdf Inserts)

Process Fluid Warning

—  **WARNING** —

If process containing parts are to be disassembled:

1. Make sure that process fluid is not under pressure or at high temperature.
 2. Take proper precautions concerning leakage or spillage of any toxic or otherwise dangerous fluid. Follow any Material Safety Data Sheet (MSDS) recommendations.
-

Seal or Sensor Fill Fluid Warning

—  **WARNING** —

Even though the volume of fill fluid is small, be sure that the fill fluid can mix safely with the process fluid.

Parts Replacement Warning

—  **WARNING** —

This product contains components that have critical safety characteristics. Do **not** substitute components. Replace components only with identical factory supplied components. Component substitution may impair the electrical safety of this equipment and its suitability for use in hazardous locations.

EC Declaration of Conformity

We, Manufacturer:

Invensys Systems, Inc.
33 Commercial Street
Foxboro, Massachusetts 02035
U.S.A.

declare under our sole responsibility that the

I/A Series Pressure Transmitters IGP, IAP, IDP, IPI, IMV

are in conformity with the protection requirements of Council Directives:

- ◆ 2004/108/EC on the approximation of the laws of the Member States relating to Electromagnetic Compatibility
- ◆ 94/9/EC on the approximation of the laws of the Member States concerning equipment and protective systems intended for use in potentially explosive atmospheres
- ◆ 97/23/EC on the approximation of the laws of the Member States concerning pressure equipment

The basis on which Conformity is being declared:

- ◆ EN 61326-1:2006, Electrical equipment for measurement, control and laboratory use EMC requirements, Class A emission limits, and immunity requirements according to Table 2 for Industrial locations.
- ◆ EN50014 1997 A1 1999 A2 1999 Electrical apparatus for potentially explosive atmospheres 'General Requirements'.
- ◆ EN50018 2000 Electrical apparatus for potentially explosive atmospheres 'Flameproof enclosures 'd''.
- ◆ EN50020 1995 Electrical apparatus for potentially explosive atmospheres 'Intrinsic safety 'I''.
- ◆ EN50021 1999 Electrical apparatus for potentially explosive atmospheres 'Type of protection 'n''.
- ◆ EN50284 1999 Special requirements for construction, test and marking of electrical apparatus of group II Category 1 G.
- ◆ EN 50281-1-1 1999 Electrical apparatus for use in the presence of combustible dust.
- ◆ EN 60079-15 2003 Electrical apparatus for explosive gas atmospheres - Part 15: Electrical apparatus with type of protection "n"

For compliance with ATEX, products are in accordance with EC Type Examination Certificates KEMA 00ATEX 1060X, KEMA 00ATEX 2019X and KEMA 00ATEX 1009X, issued by KEMA Quality B.V., Utrechtseweg 310, 6812 AR Arnhem, The Netherlands, Notified Body number 0344, and with EC Type Examination Certificates SIRA 04ATEX1349, SIRA 04ATEX2335X, SIRA 06ATEX4056X, SIRA 06ATEX2055X, and SIRA 06ATEX4019X, issued by Sira Certification Service, Rake Lane, Eccleston, Chester, CH4 9JN, England, Notified Body number 0518. The authorized markings for each certificate are shown below. The actual ATEX markings

on the product vary according to model code. Refer to Product Specification Sheet and marking on product for details pertaining to individual model codes.

KEMA 00ATEX1060X II 3 G EEx nL IIC T4 ... T6

II 1 GD EEx nL IIC T4 ... T6 T 135°C

KEMA 00ATEX1009X II 1 G EEx ia IIC T4 ... T6

II 1/2 G EEx ib IIC T4 ... T6

II 1 GD EEx ia IIC T4 ... T6 T 135°C

II 1/2 GD EEx ib IIC T4 ... T6 T 135°C

KEMA 00ATEX2019X II 2 G EEx d IIC T6

II 2 GD EEx d IIC T6 T 85°C

SIRA 04ATEX1349 II 2 GD EEx d IIC T6 T 85°C

SIRA 04ATEX2335X II 1G EEx ia IIC T4

SIRA 06ATEX4056X II 3 GD EEx nL IIC T4

SIRA 06ATEX2055X II 1 GD EEx ia IIC T4

SIRA 06ATEX4019X II 3 G EEx nL IIC T4

For the Pressure Equipment Directive, conformity is based on a certificate issued by Det Norske Veritas AS, Veritasveien 1, 1322 HOVIK, Norway, Notified Body number 0575, based on Maximum Working Pressure (MWP). Conformity Assessment Module "H" is applied for Models IGP, IAP, IMV and IDP where the MWP is greater than 200 bar. Conformity Assessment Module "A" is applied for Model IGP where the MWP is greater than 1000 bar. The applicable design standards are ANSI / ISA S82.03 and ASME Boiler Code, Section VIII.

2. Installation

— **! CAUTION** —

To avoid damage to the transmitter sensor, do not use any impact devices, such as an impact wrench or stamping device, on the transmitter.

— **NOTE** —

1. The transmitter should be mounted so that any moisture condensing or draining into the field wiring compartment can exit through one of the two threaded conduit connections.
 2. Use a suitable thread sealant on all connections.
 3. If the transmitter is not installed in the vertical position, readjust zero output to eliminate the position zero effect.
-

Mechanical Installation

Differential Pressure Transmitter

The IDP10, IDP25, and IDP50 differential pressure transmitters can be supported by the process piping (Figure 6), on a bypass manifold (Figures 7 through 10), or mounted to a vertical or horizontal pipe or surface using an optional mounting bracket (Figures 11 through 16). For dimensional information, refer to DP 020-446.

— **NOTE** —

1. The IDP25 and IDP50 transmitters are only available in the Traditional Structure at this time.
 2. If the transmitter is not installed in the vertical position, readjust zero output to eliminate the position zero effect.
 3. When pvdf inserts (structure codes 78/79) are used, the process connection must be made directly to the pvdf inserts in the Hi and Lo side process covers.
 4. The transmitter should be mounted so that any moisture condensing or draining into the field wiring compartment can exit through one of the two threaded conduit connections.
-

Process-Mounted Transmitter

Figure 6 shows the transmitter mounted to and supported by the process piping.

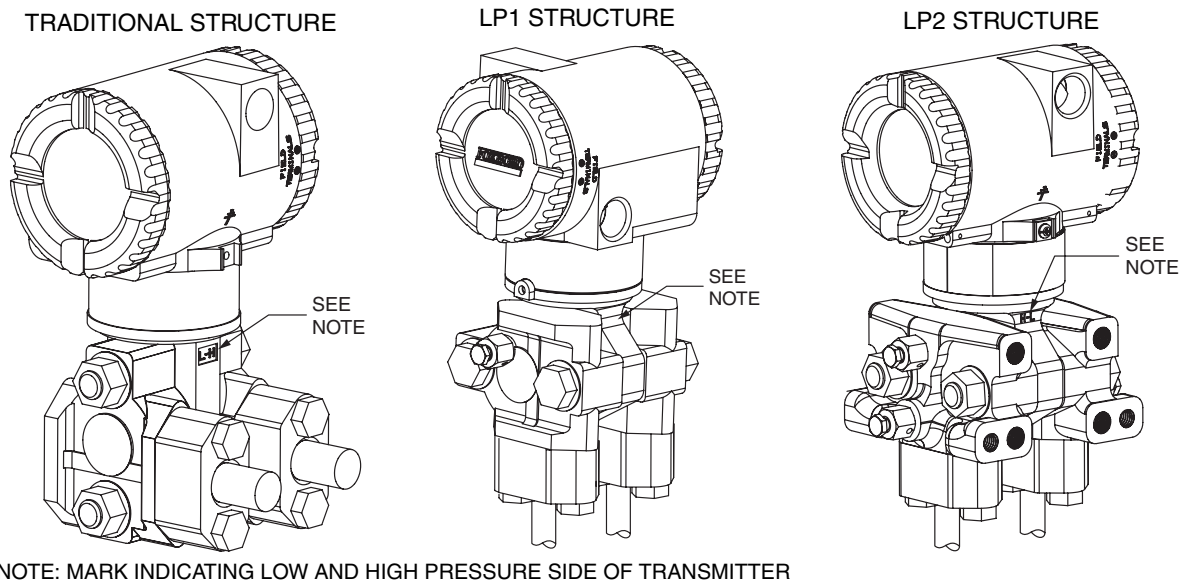

Figure 6. Typical Mounting of an IDP Transmitter Supported by Process Piping

Manifold Mounted Transmitter

Figure 7 shows the transmitter mounted to and supported by a bypass manifold. Figures 8 and 9 show a bypass manifold mounted to a DN50 (2 inch) pipe with an optional LP mounting bracket.

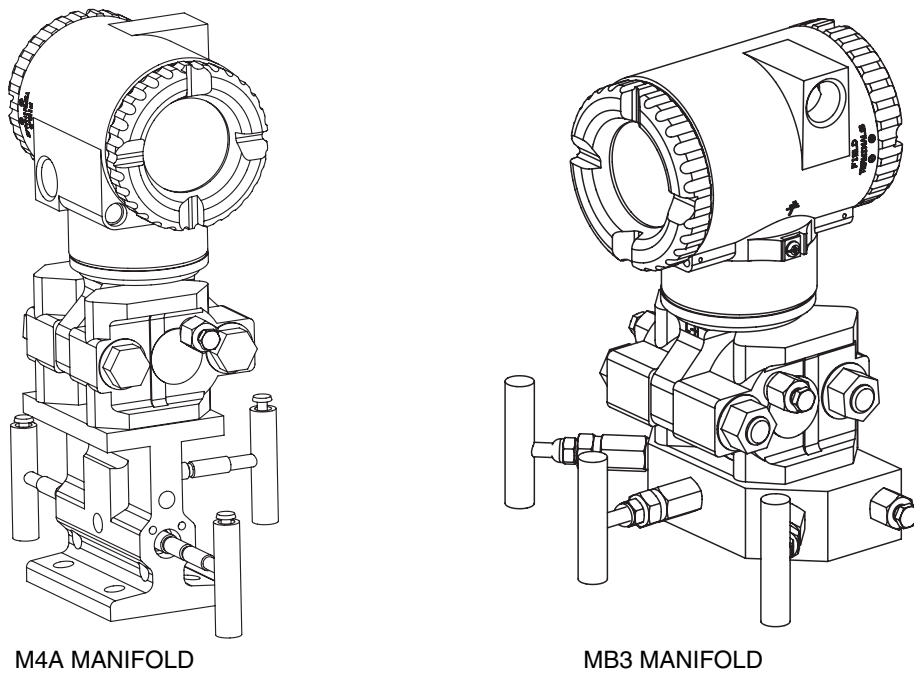

Figure 7. Typical Mounting of an IDP Transmitter Supported by a Bypass Manifold

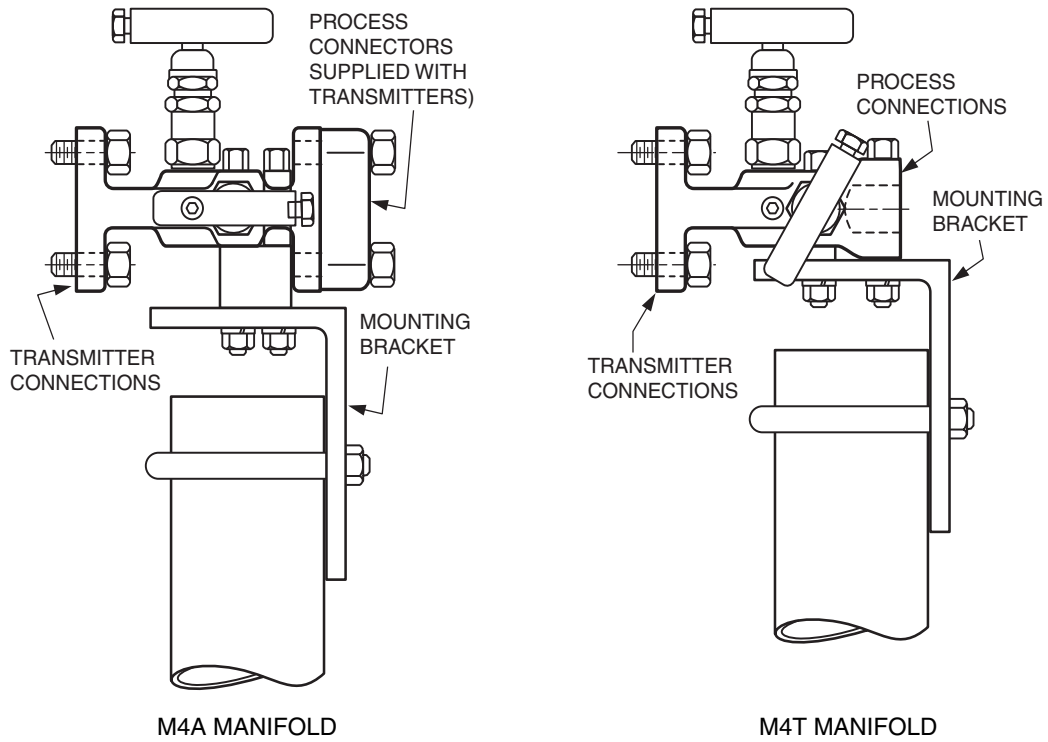

Figure 8. Typical Mounting of M4A and M4T Manifold with -AM Bracket

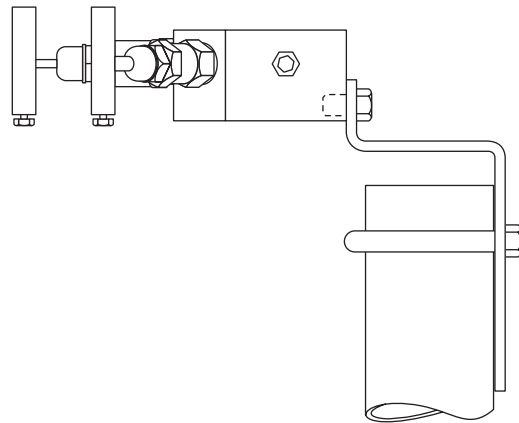

Figure 9. Typical Mounting of MB3 Manifold with -AM Bracket

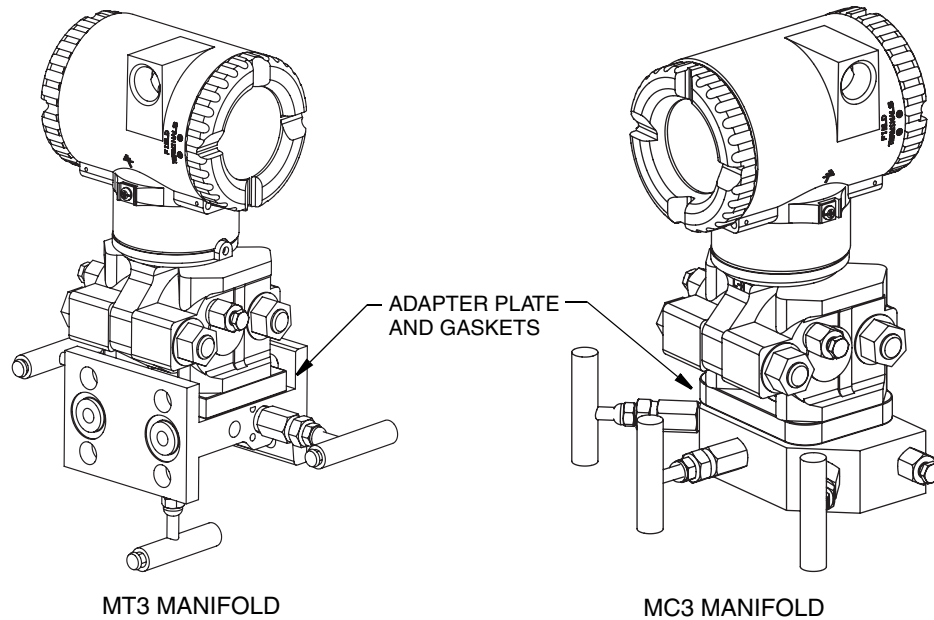

Figure 10. Typical Mounting of IMV25 Transmitter on Coplanar™ Manifold

Pipe- or Surface-Mounted Transmitter

To mount the transmitter to a pipe or surface, use the Standard Mounting Bracket Set (Model Code Option -M1 or -M2) or Universal Bracket Mounting Set (Model Code Option -M3).

Standard Mounting Bracket

The transmitter (with either traditional or LP2 low-profile structures) can be mounted to a vertical or horizontal, DN 50 or 2-in pipe using a standard bracket. See Figure 11 for details and Figure 12 for examples of different situations. Secure the mounting bracket to the transmitter using the four screws provided. Mount the bracket to the pipe. To mount to a horizontal pipe, turn the U-bolt 90° from the position shown in Figure 11. The mounting bracket can also be used for wall mounting by securing the bracket to a wall using the U-bolt mounting holes.

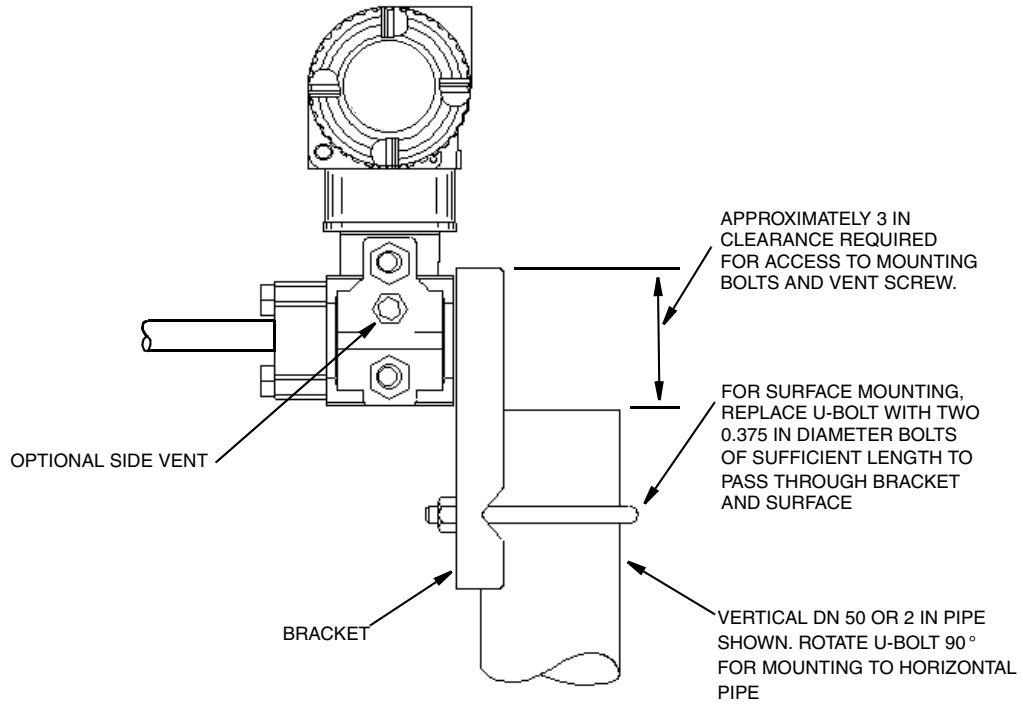

Figure 11. Pipe or Surface Mounted Transmitter Using a Standard Bracket

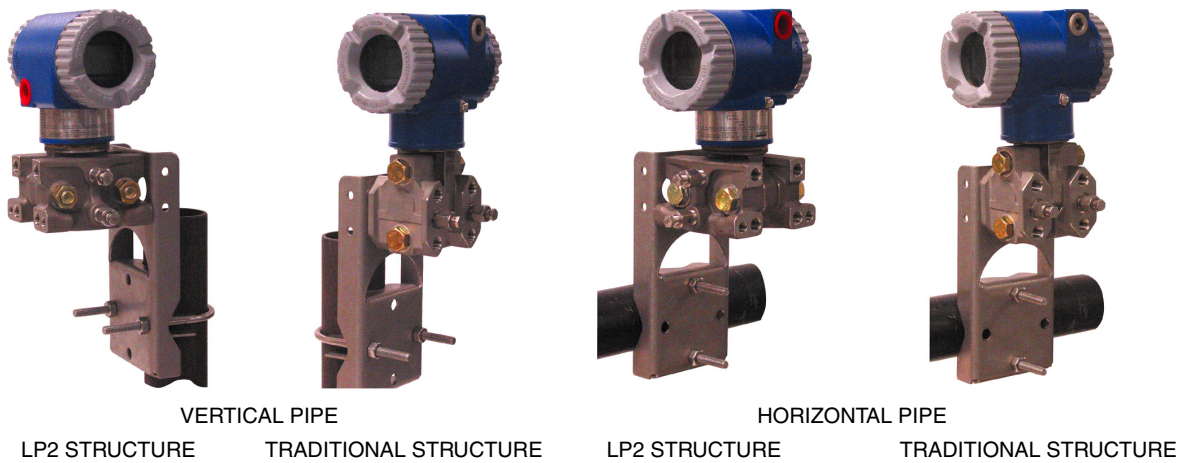

Figure 12. Examples of Mounting With a Standard Bracket

Universal Mounting Bracket

The transmitter (with either traditional or LP2 low-profile structure) can be mounted in a myriad of positions to a vertical or horizontal, DN 50 or 2-in pipe using a universal bracket. See Figure 13 for details of a universal bracket and Figure 14 through Figure 16 for examples of different mounting situations. Secure the mounting bracket to the transmitter using the two long or four short screws provided. Mount the bracket to the pipe. The mounting bracket can also be used for wall mounting by securing the bracket to a wall using the U-bolt mounting holes.

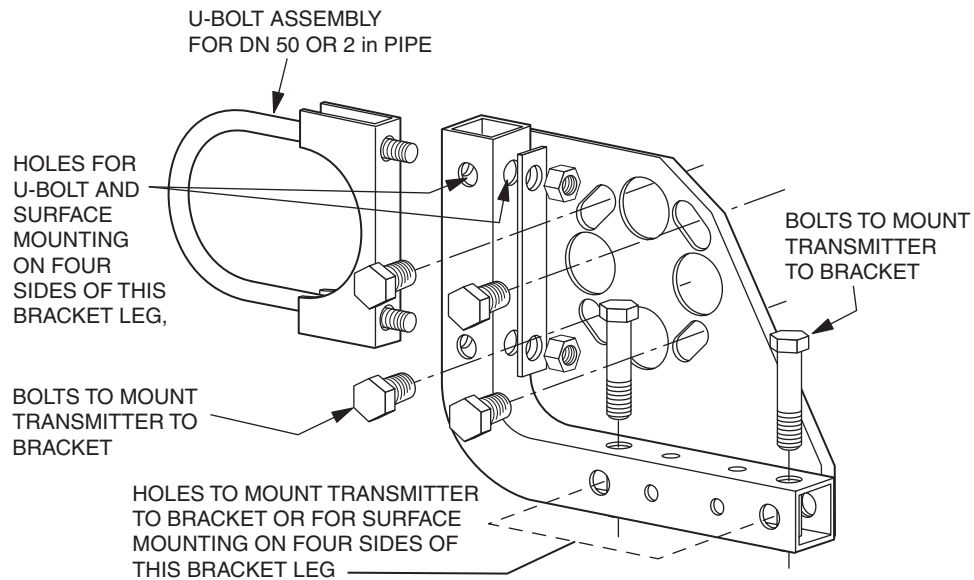

Figure 13. Details of a Universal Bracket

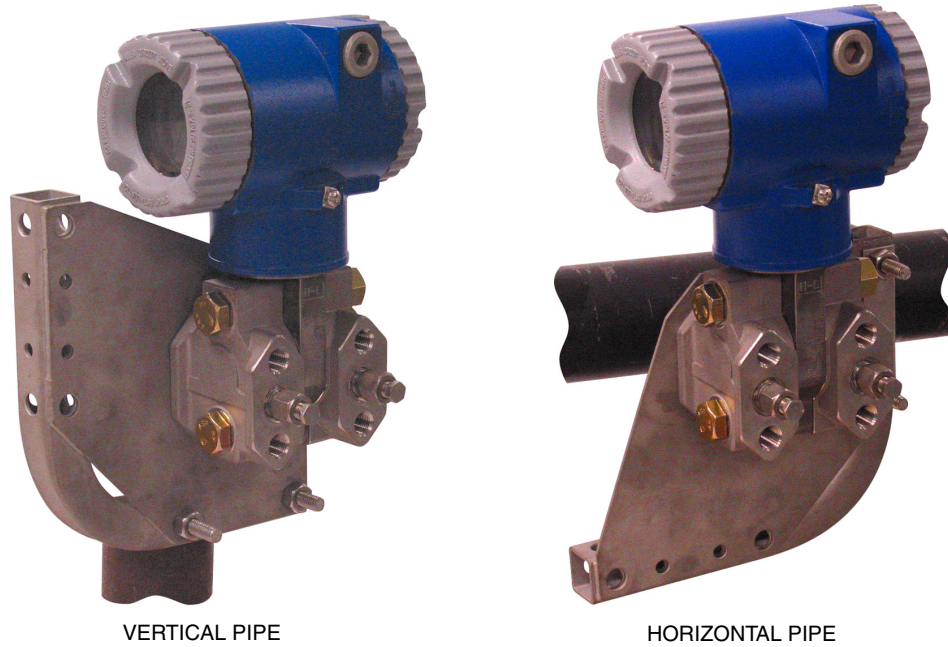

Figure 14. Mounting a Transmitter with Traditional Structure Using a Universal Bracket

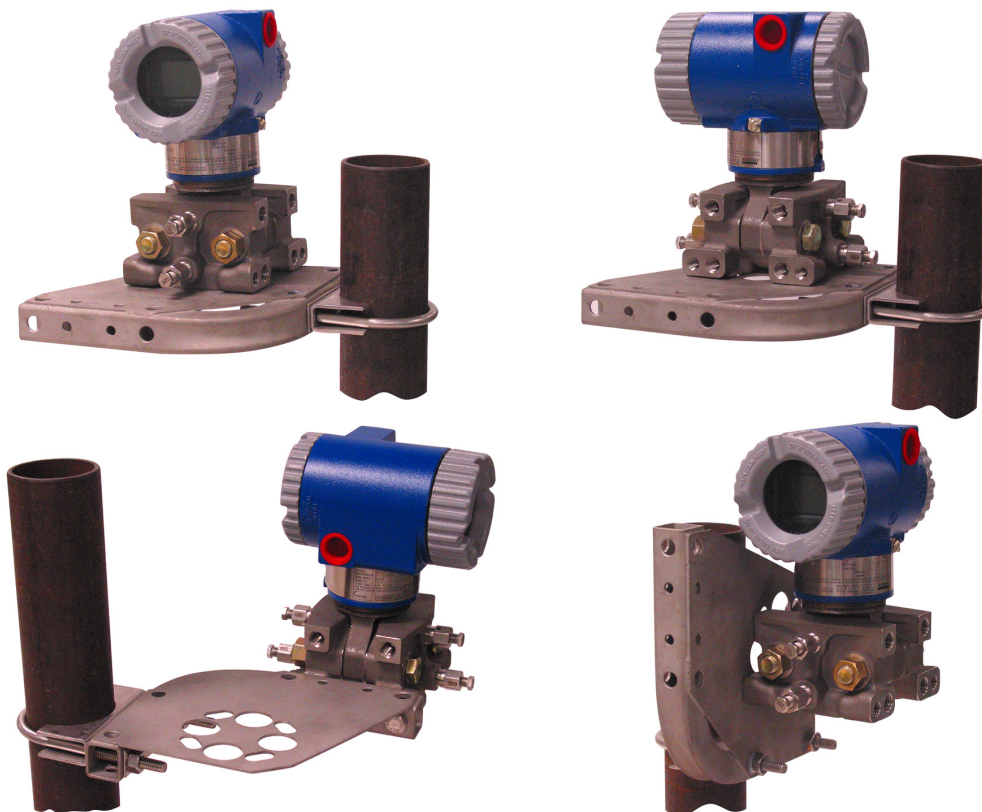

Figure 15. Vertical Pipe Mounting a Transmitter with LP2 Structure Using a Universal Bracket



Figure 16. Horizontal Mounting a Transmitter with LP2 Structure Using a Universal Bracket

Venting and Draining

Traditional Structure

Sensor cavity venting and draining is provided for both vertical and horizontal mounting. For vertical mounted units, draining is via a drain screw shown in Figure 17 and venting is possible with side vents (Option Code -V) shown in Figure 18. For horizontal mounted units, the unit is self draining and venting is via a vent screw shown in Figure 19.

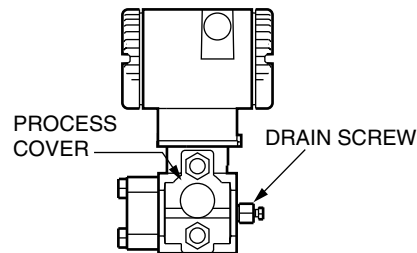

Figure 17. Vertical Mounting - Cavity Draining

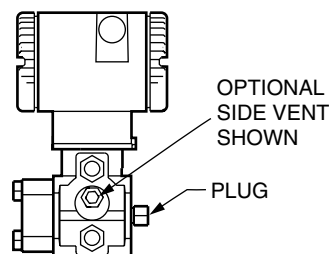

Figure 18. Vertical Mounting - Cavity Venting

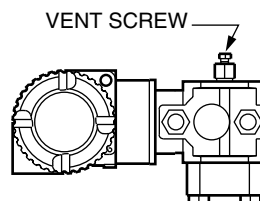

Figure 19. Horizontal Mounting - Cavity Venting

LP1 Low Profile Structure

Sensor cavity venting and draining is provided for both vertical and horizontal mounting. For vertical mounted units, the transmitter is self draining and venting is via a vent screw shown in Figure 20. For horizontal mounted units, the transmitter can simply be 'turned over' (rotated 180 degrees) as shown in Figure 21 to orient the high and low pressure sides in the preferred locations. There is no need to unbolt the process covers. If the transmitter is connected with a

length of impulse piping, such piping should slope up to the transmitter for gas applications and down for liquid applications.

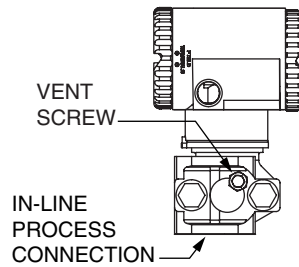

Figure 20. Vertical Mounting - Cavity Venting



Figure 21. Horizontal Mounting - Cavity Venting and Draining

LP2 Low Profile Structure

The transmitter with LP2 low profile structure had a full-featured vent and drain design with separate vent and drain screws positioned in each cover for complete venting and draining from the sensor cavity when installed in the upright position. See Figure 22.

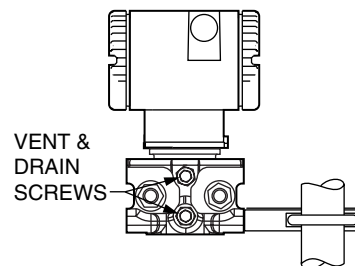

Figure 22. Cavity Venting and Draining

Installation of Flow Measurement Piping

Figure 23 and Figure 24 show typical installations with horizontal and vertical process pipes.

The transmitters are shown below the level of the pressure connections at the pipe (usual arrangement, except for gas flow without a seal liquid), and with filling tees in the lines to the transmitter (for a seal liquid).

If the process fluid being measured must not come in contact with the transmitter, the transmitter lines must be filled with a suitable seal liquid (see procedure in next section). In such a case, the

transmitter must be mounted below the level of the pressure connections at the pipe. With steam flow, the lines are filled with water to protect the transmitter from the hot steam. The seal liquid (or water) is added to the lines through the filling tees. To prevent unequal heads on the transmitter, the tees must be at the same elevation (as shown in Figure 23) and the transmitter must be mounted vertically (as shown). If a seal liquid is not required, elbows can be used in place of the tees.

Tighten drain plugs and optional vent screws to 20 N·m (15 lb·ft). Tighten the four process connector bolts to a torque of 61 N·m (45 lb·ft).

Note that the low and high pressure sides of the transmitter are identified by an L-H marking on the side of the sensor above the warning label.

With medium-viscosity seal liquids and/or long transmitter lines, larger valve sizes should be used.

— **NOTE**

1. With a **horizontal** line, pressure connections at the pipe should be at the side of the line. However, with gas flow without a seal liquid, connections should be at the top of the line.
 2. With a **vertical** line, flow should be upwards.
 3. For **liquid** or **steam** flow, the transmitter should be mounted **lower** than the pressure connections at the pipe.
 4. For **gas** flow **without** a seal liquid, the transmitter should be mounted **above** the pressure connections at the pipe; for **gas** flow **with** a seal liquid, the transmitter should be mounted **below** the pressure connections.
 5. Invensys recommends the use of snubbers in installations prone to high levels of fluid pulsations.
-

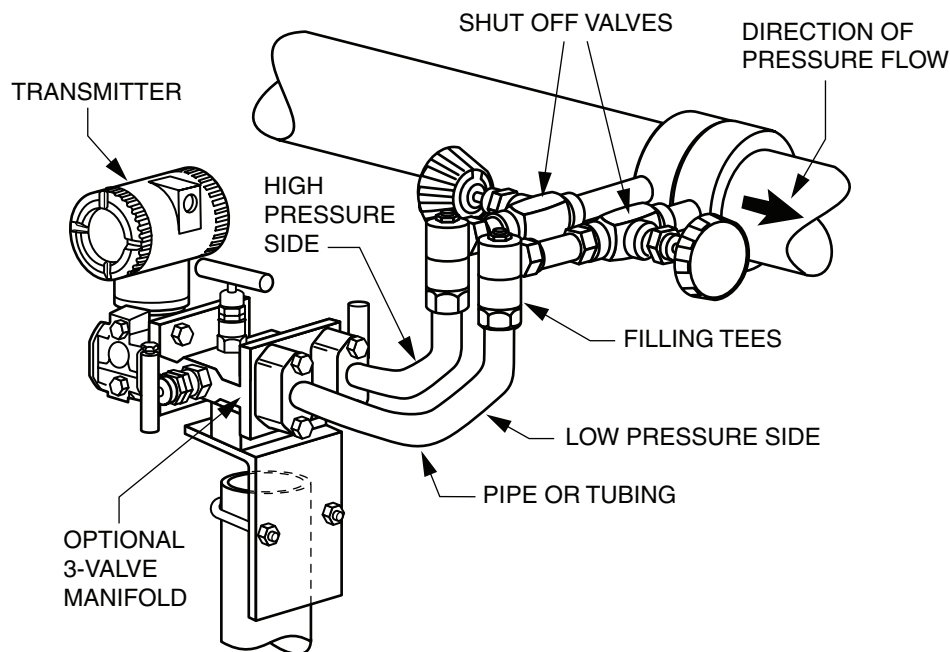

Figure 23. Example of Horizontal Process Line Installation

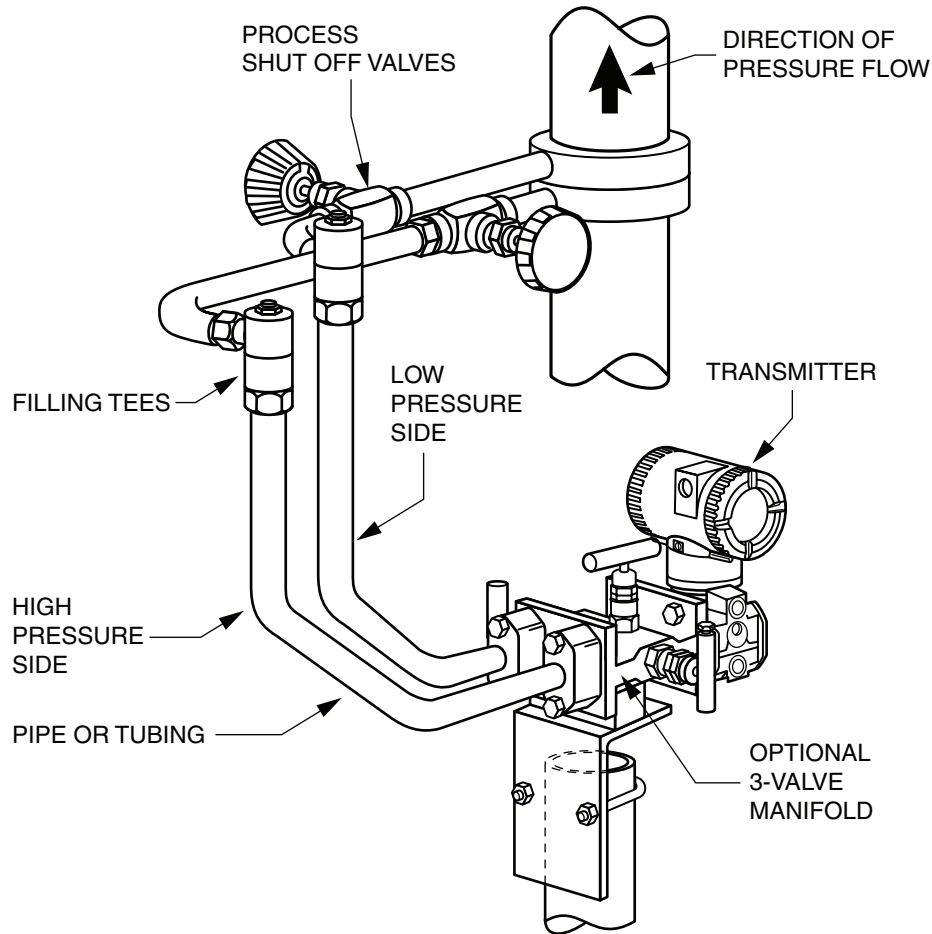

Figure 24. Example of Vertical Process Line Installation

Filling System with Seal Liquid

If the process fluid being measured must not come in contact with the transmitter, the transmitter lines must be filled with a suitable seal liquid. The procedure to do this is as follows:

1. If the transmitter is in service, follow the procedure for “Taking a Differential Pressure Xmtr Out of Operation” on page 50.
2. Close both process shutoff valves.
3. Open all three valves on 3-Valve Manifold.
4. Partially open the vent screws on the transmitter until all air has been forced out of the transmitter body and lines. Close the vent screws.
5. Refill the tee connections. Replace the plugs and close the bypass valve. Check for leaks.
6. Follow the procedure for “Putting a Differential Pressure Xmtr Into Operation” on page 50.

! CAUTION

To prevent loss of seal liquid and contamination of process fluid, never open both process shutoff valves and manifold shutoff valves if the bypass valve is open.

Absolute and Gauge Pressure Transmitter

! CAUTION

For 3-A compliant sanitary applications (Models IGP10, IAP10, IGP25-..T, -..M....)

Process wetted surface (diaphragm convolutions) should be installed so that process does not pool between convolutions when the vessel is empty.

The transmitter should be mounted in such a way that nonprocess wetted surfaces are self draining. It should be installed horizontal to vertical, so that the crevice at the feature where the housing is attached to the sensor (neck) is self draining.

The design of these devices does not comply with paragraph D10.1.2 for 3-A standard 74-03 compliance.

IAP10, IGP10, IGP25 and IGP50 Transmitters

These pressure transmitters can be directly connected to the process using the 1/2 NPT external thread or mounted to a vertical or horizontal pipe or a surface using the Optional Mounting Set (Model Code Option -M1 through -M6) as shown in Figure 25.

NOTE

1. Do **not** direct mount these transmitters to the process using the 1/4 NPT internal thread. This thread should only be used to connect to the process when the transmitter is mounted with the optional mounting set.
 2. Do **not** mount these transmitters using the conduit connection and optional mounting set when vibration conditions exceed 20 m/s^2 (2 "g").
-

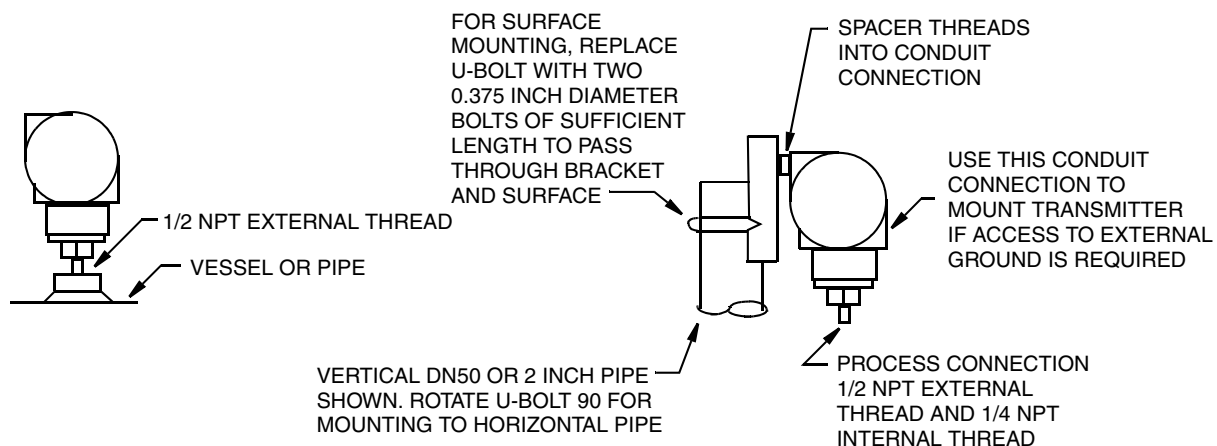

Figure 25. IAP10, IGP10, IGP25, and IGP50 Transmitter Mounting

IAP20 and IGP20 Transmitters

To mount these transmitter to a pipe or surface, use the Optional Mounting Set (Model Code Option -M1 or -M2). Referring to Figure 26, secure the mounting bracket to the transmitter using the two screws provided. Mount the transmitter with the mounting bracket to a vertical or horizontal DN50 or 2-inch pipe. To mount to a horizontal pipe, turn the U-bolt 90° from the position shown in Figure 26. The mounting bracket can also be used for wall mounting by securing the bracket to a wall using the U-bolt mounting holes.

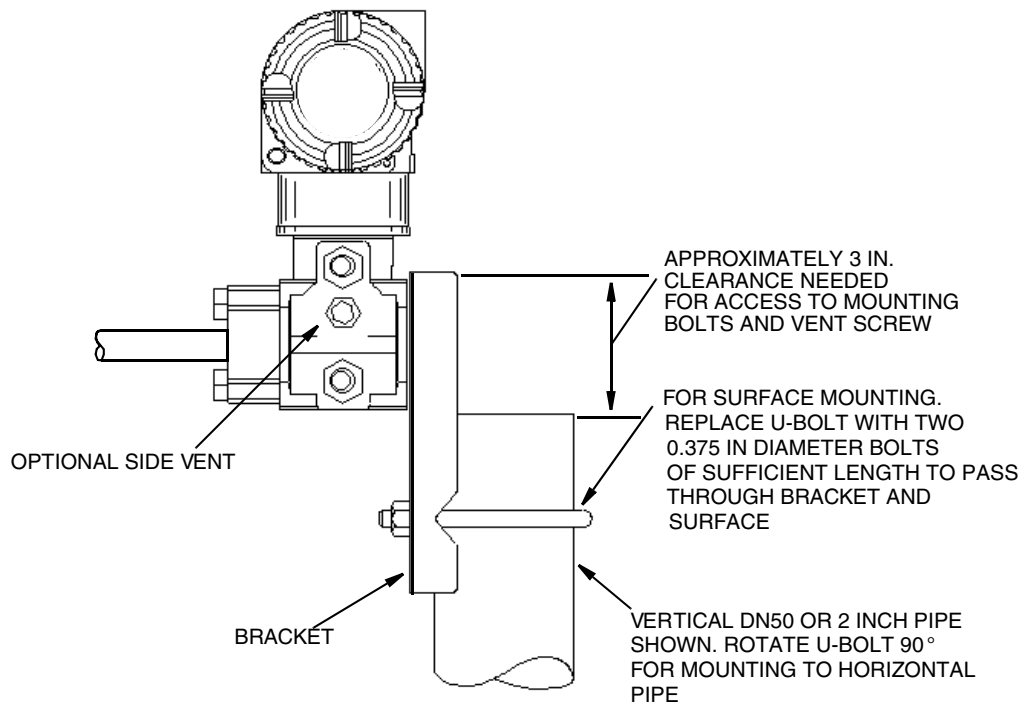

Figure 26. IAP20 and IGP20 Transmitter Mounting

— NOTE —

When structure codes 78/79 are used (pvdf insert), the process connection must be made directly to the pvdf insert in the process cover.

Typical Transmitter Piping

Figure 27 shows a typical piping application. Calibration supply pressure can be applied via a calibration tee or calibration screw. The lower conduit port can be used as a drain for moisture buildup in terminal compartment. For Model IAP20, IGP20, IGP25, and IGP50 Transmitters, tighten the process connector bolts to a torque of 61 N·m (45 lb·ft) and drain plugs and vent screws to a torque of 20 N·m (15 lb·ft).

— NOTE

1. Invensys recommends the use of snubbers in installations prone to high levels of fluid pulsations.
 2. IAP10, IGP10, IGP25, and IGP50 Transmitters mounted directly to process piping or a pressure vessel as shown in Figure 27, could require the use of a shutoff valve (shown) to comply with the requirements of ASME Power Piping Code B31.1 and Chemical and Petroleum Piping Code B31.3.
-

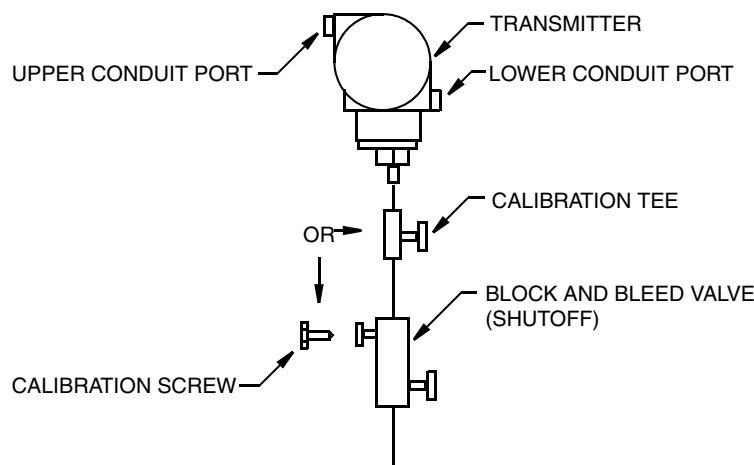

Figure 27. Typical Transmitter Piping (IGP10 shown)

For hot process applications above the operative limits of your transmitter [121 °C (250 °F)], such as steam, additional piping is required to protect the transmitter from the hot process. See Figure 28. The piping is filled with water or process fluid. Mount the transmitter below the pressure connection at the pipe. Although the transmitter is shown mounted vertically, you can also mount it horizontally unless sediment is present. The calibration tee is not required if a calibration screw is used for field calibrations.

If trapped vapor pockets cannot be tolerated in a liquid service and a horizontal process connection is used, install a pipe elbow and vertically position the transmitter with the housing **below** the process connection.

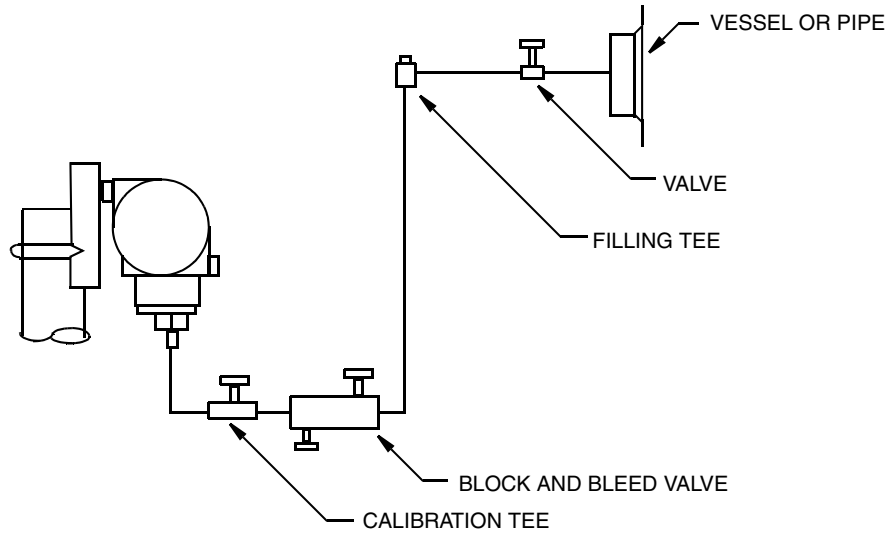

Figure 28. Hot Process Piping

Transmitter with Seals

For information on transmitters with seals, refer to MI 029-369 on your CD-ROM.

Capillary fill fluid specific gravities are given in Table 14 for your convenience.

Table 14. Capillary Fill Fluid Specific Gravities

Fill Fluid Code	Fill Fluid	Specific Gravity at 21°C (70°F)
1	DC200, 10cS, Silicone	0.94
2	FC77 Fluorinert	1.78
3	DC200, 3cS, Silicone	0.90
4	DC704 (HTF) Silicone	1.07
5	Neobee	0.92

Positioning the Housing

The transmitter housing (topworks) can be rotated up to one full turn in the counterclockwise direction when viewed from above for optimum access to adjustments, display, or conduit connections. Housings have either an anti-rotation screw or a retention clip that prevent the housing from being rotated beyond a safe depth of housing/sensor thread engagement.

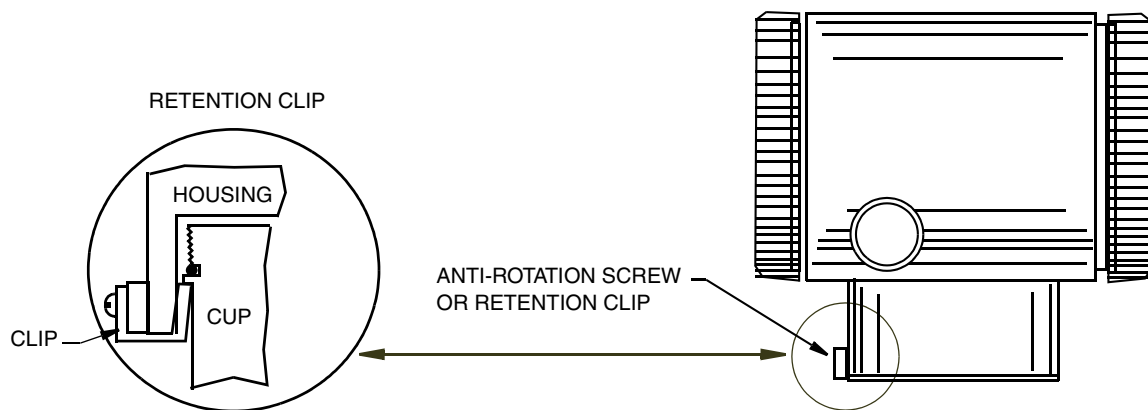

Figure 29. Housing Screw or Clip Location

Positioning the Display

The display (optional in some models) can be rotated within the housing to any of four positions at 90° increments. To do this with the optional removable display, grasp the two tabs on the display and rotate it about 10° in a counterclockwise direction. Pull out the display. Ensure that the O-ring is fully seated in its groove in the display housing. Turn the display to the desired position, reinsert it in the electronics module, aligning the tabs on the sides of the assembly, and twist it in the clockwise direction. With electronics versions -A and -V, the display is a standard part of the electronics module and can be rotated by repositioning the entire module, using the mounting screws.

— **! CAUTION** —

Do **not** turn the display more than 180° in any direction. Doing so could damage its connecting cable.

Setting the Write Protect Jumper

— **NOTE** —

This feature only applies to transmitters with FoxCom (Code -D), HART (Code -T), and FOUNDATION fieldbus (Code -F) electronics.

If your transmitter has write protection capability, it means that the external zero, local display, and remote communications can be prevented from writing to the electronics. Write protection is set by moving a jumper that is located in the electronics compartment behind the optional

display. To activate write protection, remove the display as described in the previous section, then remove the jumper or move it to the lower position as shown on the exposed label. Replace the display.

Cover Locks

Electronic housing cover locks, shown in Figure 30, are provided as standard with certain agency certifications and as part of the Custody Transfer Lock and Seal option. To lock the covers, unscrew the locking pin until approximately 6 mm (0.25 in) shows, lining up the hole in the pin with the hole in the housing. Insert the seal wire through the two holes, slide the seal onto the wire ends and crimp the seal.

Wiring

The installation and wiring of your transmitter must conform to local code requirements.

— NOTE —

Although surge protection is standard, Invensys recommends the use of transient/surge protection in installations prone to unusually high levels of electrical transients and surges.

For access to the field terminals, thread the cover lock (if present) into the housing to clear the threaded cover and remove the cover from the field terminals compartment as shown in Figure 30. Note that the embossed letters **FIELD TERMINALS** identify the proper compartment.

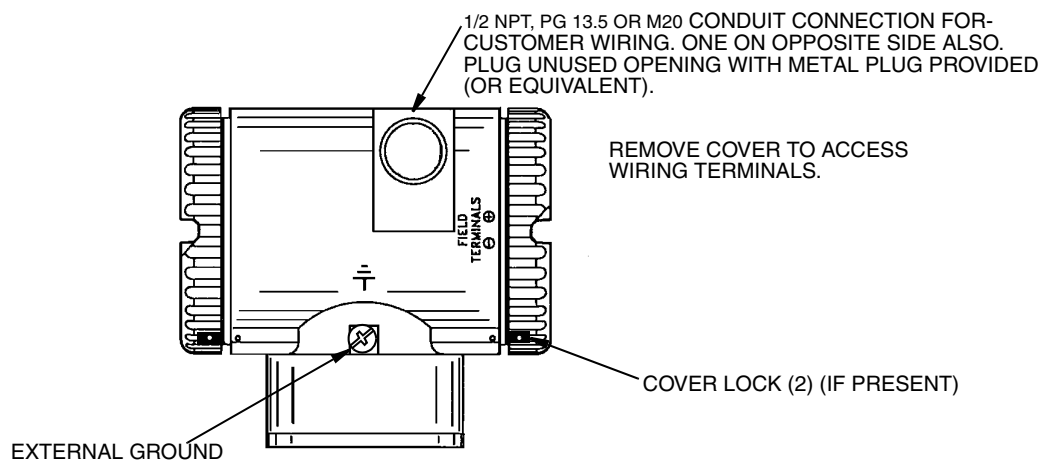

Figure 30. Accessing Field Terminals

4 to 20 mA Output Signal (Model Codes -A, -D, and -T)

The field terminals on a transmitter with a 4 to 20 mA output signal are shown in Figure 31.

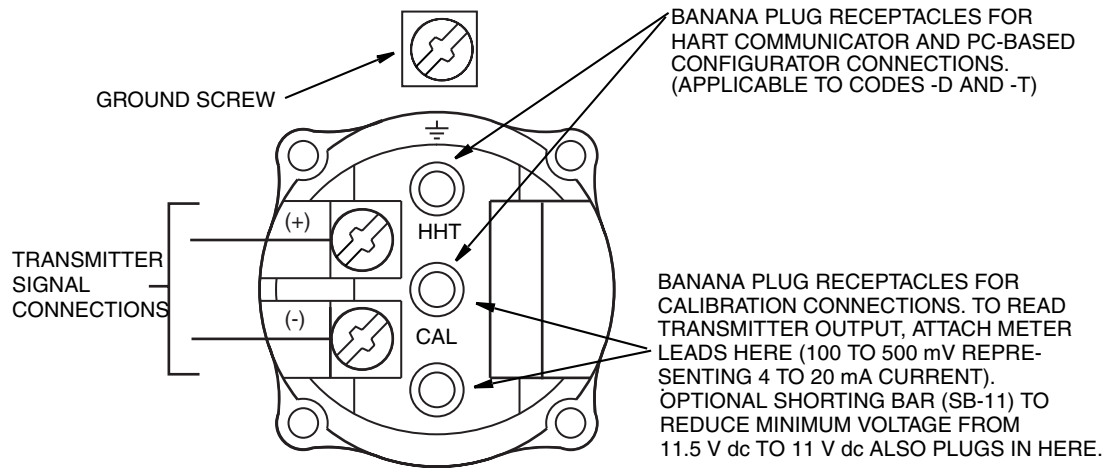

Figure 31. Identification of Field Terminals

The transmitter is equipped with an internal ground connection within the field wiring compartment and an external ground connection at the base of the electronics housing. To minimize galvanic corrosion, place the wire lead or terminal between the captive washer and loose washer on the external ground screw.

When wiring a transmitter with 4 to 20 mA output signal, the supply voltage and loop load must be within specified limits. The supply output load vs. voltage relationship is:

$$R_{\text{MAX}} = 47.5 (V - 11.5) \text{ and is shown in Figure 32.}$$

— NOTE —

The relationship when the optional shorting bar is used is:

$$R_{\text{MAX}} = 46.8 (V - 11).$$

Any combination of supply voltage and loop load resistance in the shaded area can be used. To determine the loop load resistance (transmitter output load), add the series resistance of each component in the loop, excluding the transmitter. The power supply must be capable of supplying 22 mA of loop current.

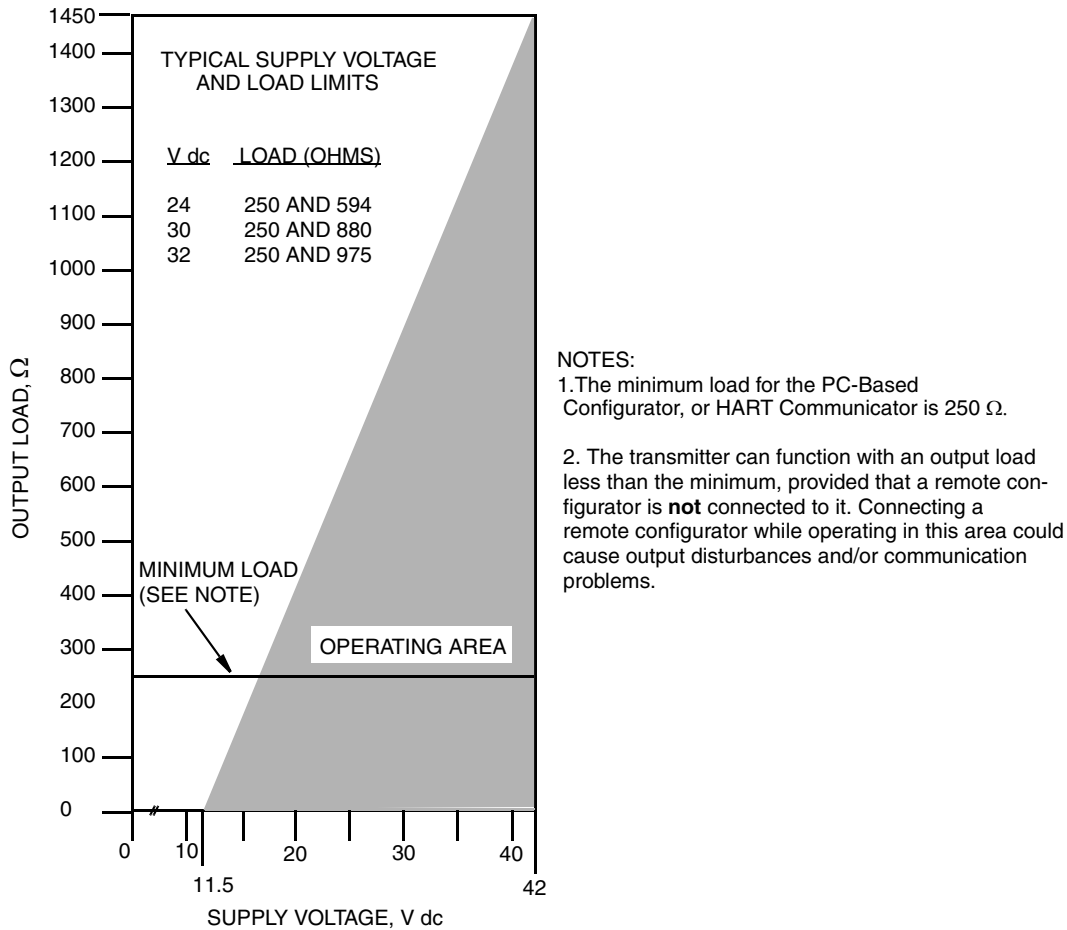

Figure 32. Supply Voltage and Loop Load

Examples:

1. For a loop load resistance of 880 Ω, the supply voltage can be any value from 30 to 42 V dc.
2. For a supply voltage of 24 V dc, the loop load resistance can be any value from 250 to 594 Ω with remote communications and zero to 594 Ω without remote communications.

To wire one or more transmitters to a power supply, proceed with the following steps.

1. Remove the cover from the transmitter field terminals compartment.
2. Run signal wires (0.50 mm² or 20 AWG, typical) through one of the transmitter conduit connections as shown in Figure 30. Use twisted pair to protect the 4 to 20 mA output and/or remote communications from electrical noise. Maximum recommended length for signal wires is 1800 m (6000 ft)

— NOTE —

Do not run transmitter wires in same conduit as mains (ac power) wires.

3. If shielded cable is used, ground (earth) the shield at the receiver **only**. Do not ground the shield at the transmitter. Cut or tape the shield so that it cannot contact the metal housing.
4. Plug the unused conduit connection with the metal plug provided (or equivalent). To maintain specified explosionproof and dust-ignitionproof protection, the plug must engage a **minimum** of five full threads.
5. Connect a ground wire to the ground terminal in accordance with local practice.

— **! CAUTION** —

If the signal circuit must be grounded, it is preferable to do so at the negative terminal of the dc power supply. To avoid errors resulting from ground loops or the possibility of short-circuiting groups of instruments in a loop, there should be only one ground in a loop.

6. Connect the power supply and receiver loop wires to the “+” and “–” terminal connections shown in Figure 31.
7. Connect receivers (such as controllers, recorders, indicators) in series with power supply and transmitter as shown in Figure 33.
8. Install the cover onto the transmitter. Turn covers to seat O-ring into the housing and then continue to hand tighten until the cover contacts the housing metal-to-metal. If cover locks are present, refer to “Cover Locks” on page 36.
9. If wiring additional transmitters to the same power supply, repeat Steps 1 through 8 for each additional transmitter. The setup with multiple transmitters connected to a single power supply is shown in Figure 34.
10. The PC-Based Configurator can be connected in the loop between the transmitter and the power supply as shown in Figure 33 and Figure 34 (not applicable with Version -A). Note that a minimum of 250 Ω must separate the power supply from the PC-Based Configurator or HART Communicator).

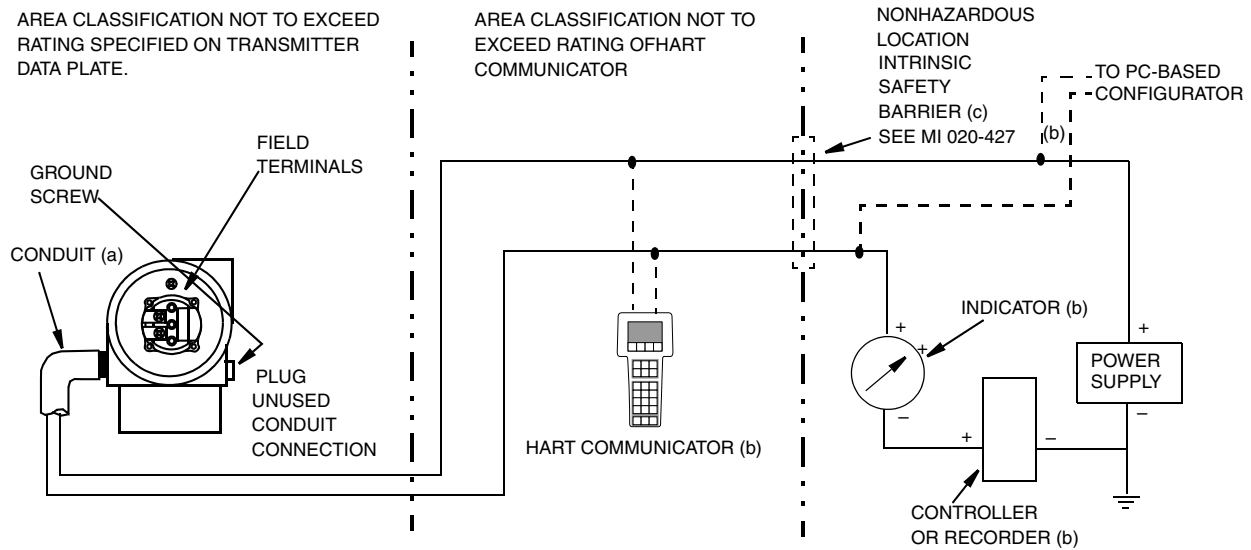

- (a) RUN CONDUIT DOWN TO AVOID MOISTURE BUILDUP IN TERMINALS COMPARTMENT.
- (b) THERE MUST BE AT LEAST 250 Ω TOTAL RESISTANCE BETWEEN THE PC-BASED CONFIGURATOR OR HART COMMUNICATOR AND THE POWER SUPPLY).
- (c) TRANSMITTERS WITH -A ELECTRONICS ARE NOT DESIGNED FOR USE WITH INTRINSIC SAFETY BARRIERS.

WARNING

DIFFERENT VERSIONS OF THE HART COMMUNICATOR MAY BE SUITABLE FOR DIFFERENT CLASSIFICATIONS (FOR EXAMPLE, DIVISION 1 OR DIVISION 2). CHECK THE RATING OF THE VERSION YOU HAVE BEFORE USING IT IN A HAZARDOUS AREA. LOCATING OR CONNECTING A HART COMMUNICATOR IN A HAZARDOUS AREA FOR WHICH IT IS NOT CERTIFIED COULD RESULT IN AN EXPLOSION.

Figure 33. Loop Wiring 4 to 20 mA Output Transmitters

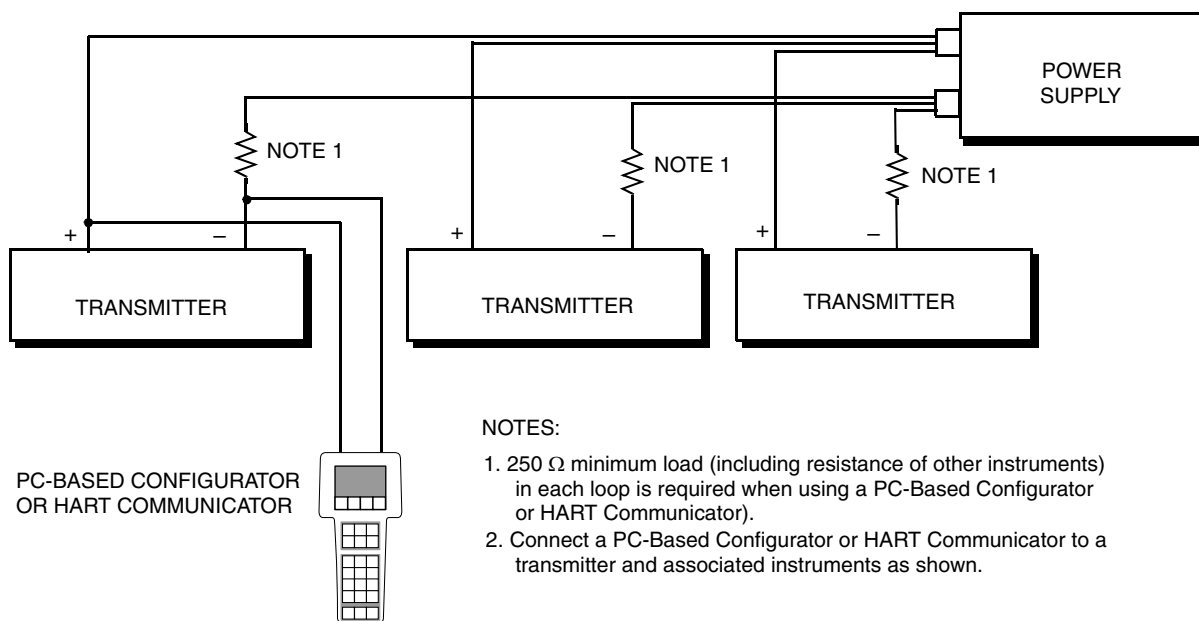

- NOTES:
1. 250 Ω minimum load (including resistance of other instruments) in each loop is required when using a PC-Based Configurator or HART Communicator).
 2. Connect a PC-Based Configurator or HART Communicator to a transmitter and associated instruments as shown.

Figure 34. Wiring Several 4 to 20 mA Transmitters to a Common Power Supply

The transmitters with FoxCom (-D) and HART (-T) communications also communicate digitally with the PC-Based Configurator and the HART Communicator respectively at distances up to 1800 m (6000 ft). Communication between the remote configurator and the transmitter does not disturb the 4 to 20 mA output signal.

HART Multidrop Wiring (Model Code -T)

“Multidropping” refers to the connection of several transmitters to a single communications transmission line. Communications between the host computer and the transmitters takes place digitally with the analog output of the transmitter deactivated. With the HART communications protocol, up to 15 transmitters can be connected on a single twisted pair of wires or over leased telephone lines.

The application of a multidrop installation requires consideration of the update rate necessary from each transmitter, the combination of transmitter models, and the length of the transmission line. Multidrop installations are not recommended where intrinsic safety is a requirement. Communication with the transmitters can be accomplished with any HART compatible modem and a host implementing the HART protocol. Each transmitter is identified by a unique address (1-15) and responds to the commands defined in the HART protocol.

Figure 35 shows a typical multidrop network. Do not use this figure as an installation diagram. Contact the HART Communications Foundation (telephone 512-794-0369 in the U.S.) with specific requirements for multidrop applications.

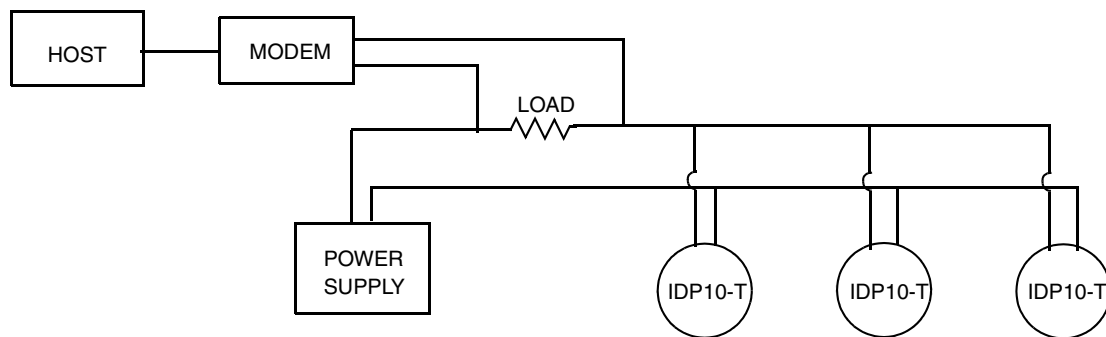

Figure 35. Typical Multidrop Network

The HART Communicator can operate, configure, and calibrate transmitters with HART communication protocol in the same way as it can in a standard point-to-point installation.

— NOTE —

Transmitters with HART communication protocol are set to poll address 0 (**POLLADR 0**) at the factory, allowing them to operate in the standard point-to-point manner with a 4 to 20 mA output signal. To activate multidrop communication, the transmitter address must be changed to a number from 1 to 15. Each transmitter must be assigned a unique number on each multidrop network. This change deactivates the 4 to 20 mA analog output.

1 to 5 V dc Output Signal (Model Code -V)

The field terminals on a transmitter with a 1 to 5 V dc output signal are shown in Figure 36.

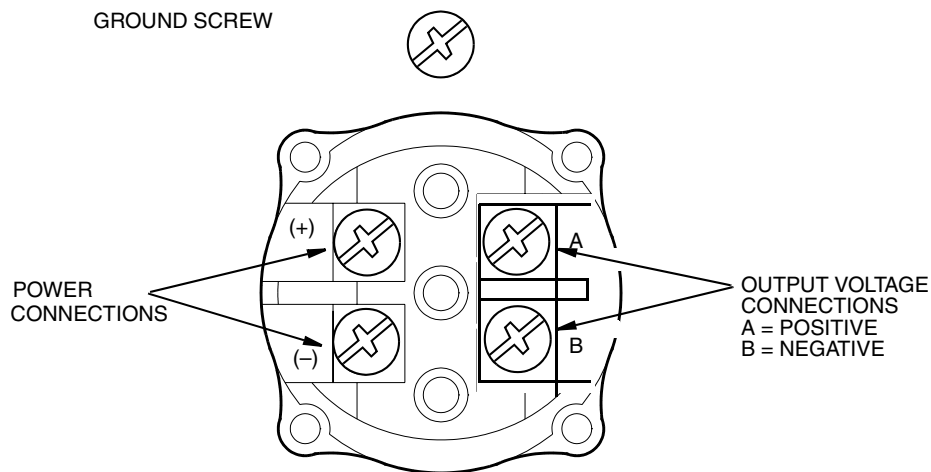

Figure 36. Identification of Field Terminals

The transmitter is equipped with an internal ground connection within the field wiring compartment and an external ground connection at the base of the electronics housing. To minimize galvanic corrosion, place the wire lead or terminal between the captive washer and loose washer on the external ground screw.

Power Supply Voltage and Current

The power supply voltage across the transmitter input terminals can be any value between 9 and 15.5 V dc and the power supply must be capable of supplying 3 mA of current under all conditions. Verify that the power supply loop load resistance and source impedance allow at least 9 V dc across the transmitter input terminals with a current draw of 3 mA.

Output Load

The receiver input impedance can be any value between 1 and 10 M Ω .

Three or Four Wire Connections

The transmitter is supplied with a four-wire terminal block with the two negative terminals (- and B) electrically connected internally. This means that the transmitter can be wired with either three wires for wiring economy or four wires for maximum accuracy.

For relatively short wiring runs having low resistance, three-wire connections as shown in Figure 37 can be used to minimize wiring costs. However, a voltage drop in the common lead carrying the power supply current causes an error in the 1 to 5 V dc signal.

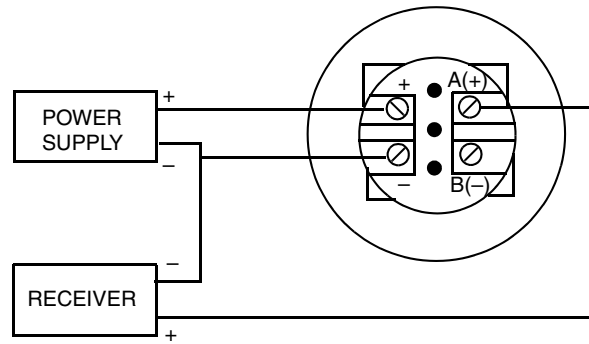

Figure 37. Three-wire Connection

For wiring runs with high resistance (due to long lengths or other reasons) or for maximum accuracy, a four-wire connection as shown in Figure 38 can be used to provide input-output isolation. With four-wire configuration, voltage drop in the power supply loop does not affect measurement accuracy.

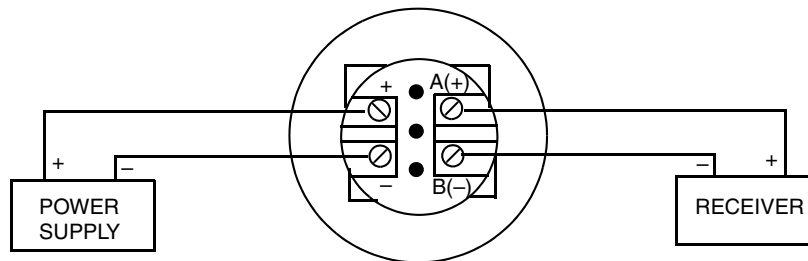

Figure 38. Four-wire Connection

To wire a transmitter, proceed with the following steps.

1. Screw in cover lock (if present) and remove the field terminals compartment cover by rotating it counterclockwise.
2. Run the supply voltage and output wires (0.50 mm² or 20 AWG, typical) through one of the transmitter conduit connections as shown in Figure 30. If four-wire connection is used, use twisted single pair on the output side to protect the 1 to 5 V dc output from electrical noise.

— **NOTE** —

Do not run transmitter wires in same conduit as mains (ac power) wires.

3. If shielded cable is used, ground the shield at the receiver **only**. Do **not** ground the shield at the transmitter. Cut and/or tape the shield so it cannot contact the metal housing.
4. Plug unused conduit connection with the metal plug provided (or equivalent). To maintain specified explosionproof and dust-ignitionproof protection, plug must engage a **minimum** of five full threads. Thread sealant is recommended.
5. Connect an ground wire to the ground terminal in accordance with local practice.

! CAUTION

If the output circuit must be grounded, it is preferable to do so at the negative terminal of the receiver. To avoid errors resulting from ground loops or the possibility of short-circuiting groups of instruments in a loop, there should be only one ground in a loop.

6. Connect the power supply and receivers (such as controllers, recorders, indicators) as shown in Figure 37 or Figure 38. Typical loop wiring is shown in Figure 39.
7. Install the cover onto the transmitter. Turn covers to seat O-ring into the housing and then continue to hand tighten until the cover contacts the housing metal-to-metal. If cover locks are present, refer to “Cover Locks” on page 36.
8. If wiring additional transmitters to the same power supply, repeat Steps 1 through 7 for each additional transmitter. The setup with multiple transmitters connected to a single power supply is shown in Figure 40.
9. For installations with long runs, Invensys recommends using two twisted pair with one pair connected to the power supply terminals and one pair connected to the output terminals. The two twisted pair can be in individual shields or a common shield with the shield connected to the receiver. The shield must **not** be connected to the transmitter.

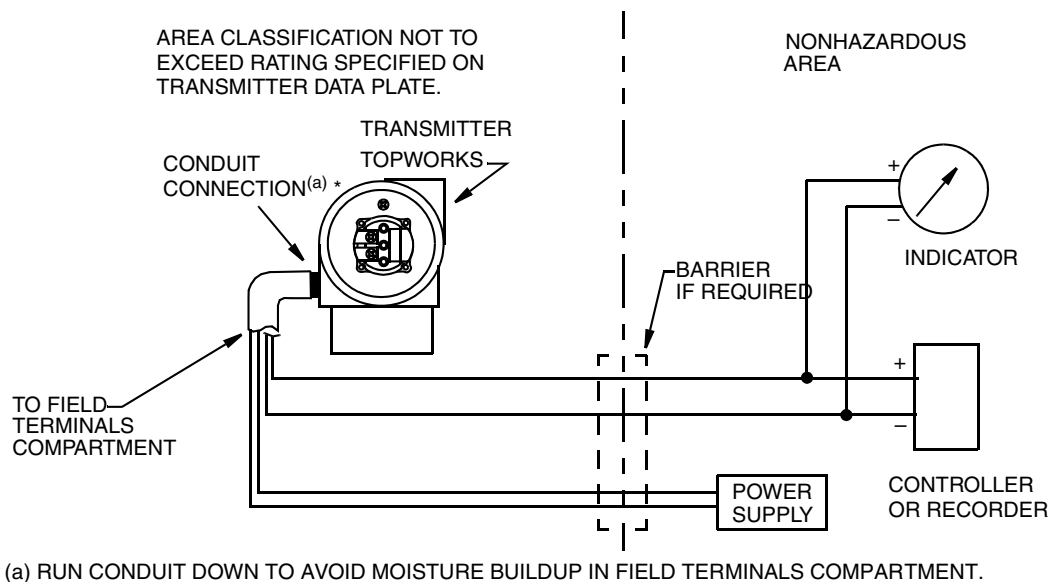
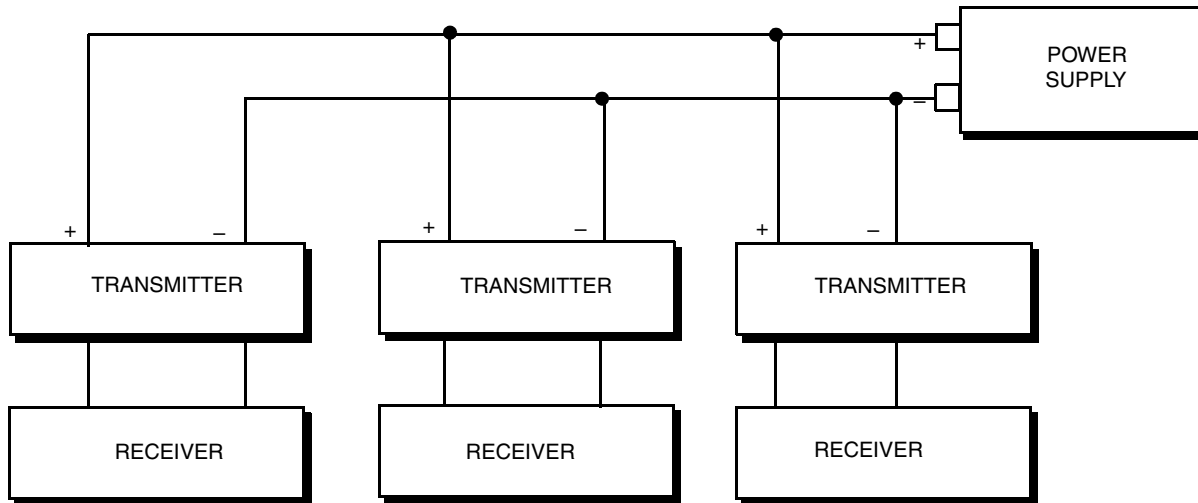

Figure 39. Loop Wiring (four-wire connection shown)



NOTE: FOUR WIRE CONNECTION SHOWN

Figure 40. Wiring Several Transmitters to a Common Power Supply

FoxCom Communications Protocol (Model Code -D)

The transmitter can be configured to send its pressure measurement to the I/A Series system as a digital signal using FoxCom protocol. Remote communication between the transmitter and the PC-Based Configurator or any I/A Series system console can be accommodated up to 600 m (2000 ft) away from the FBM.

— NOTE —

Ensure that the transmitter output is configured for “digital output” before attaching it to an FBM that will be communicating in only the digital mode. Also, make sure that Device Name is the same as the letterbug used for that channel in the I/A Series System, or verify that the transmitter device name is set to its default description, DevNam, before installation.

Transmitters with FoxCom digital output signal connect to an I/A Series system. This procedure identifies wire terminations in the transmitter and in the I/A Series system enclosure. For other system wiring details, refer to the Installation Instructions provided with the I/A Series system.

The maximum total resistance for each transmitter loop is 420 Ω . For example, if an intrinsically safe barrier with a resistance of 340 Ω is used, the maximum wire resistance is 80 Ω . Maximum recommended length for field wire is 600 m (2000 ft). Transmitter power is supplied by the I/A Series FBM.

1. Remove the cover from the transmitter field terminal compartment.
2. Run signal wires (0.50 mm² or 20 AWG, typical) through one of the transmitter conduit connections as shown in Figure 41. Use twisted pair to protect the digital output and/or remote communications from electrical noise. Screened (shielded) cable may be required in some locations.

— NOTE —

Do not run transmitter wires in same conduit as mains (ac power) wires.

3. If shielded cable is used, ground the shield at the field enclosure **only**. Do not ground the shield at the transmitter.
4. Plug unused conduit connection with the PG 13.5 or 1/2 NPT metal plug provided (or equivalent). To maintain specified explosionproof and dust-ignitionproof protection, plug must engage a **minimum** of five full threads.

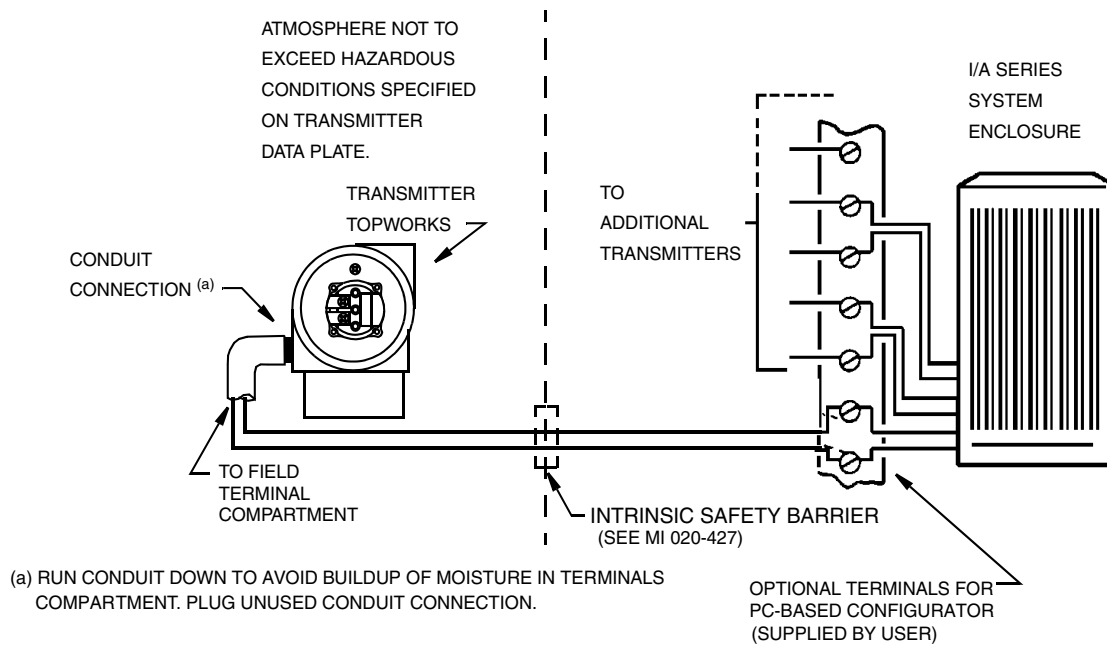

Figure 41. Typical Transmitter Wiring to an I/A Series System

5. Connect an ground wire to the ground terminal in accordance with local practice. Ground terminal is shown in Figure 31.

! CAUTION

To avoid errors resulting from ground loops or the possibility of short-circuiting groups of instruments in a loop, use only one ground in a loop.

6. Connect the signal wires to the transmitter “+” and “-” terminal connections shown in Figure 31.
7. The PC-Based Configurator can be connected via banana plugs to the top two receptacles (designated **HHT**) on the terminal block in the field terminal compartment as shown in Figure 31 or any other convenient location in the loop (subject to hazardous location restrictions). For example, to communicate with several transmitters from a single location, connect each pair of signal wires to a separate pair of terminals. The PC-Based Configurator can then be easily disconnected from one loop and connected to another.
8. Reinstall the cover on the transmitter. Turn the cover to seat the O-Ring into the housing and continue to hand tighten until the cover contacts the housing metal-to-metal.

FOUNDATION Fieldbus Communication (Model Code -F)

Do not run transmitter wires in the same conduit as mains (ac power) wires.

Use FOUNDATION fieldbus approved cable (multi-core, shielded, twisted pair cable) to protect remote communications from electrical noise. Refer to MI 020-360 or FOUNDATION fieldbus Application Guide AG-140, Rev 1.0 or later.

Power supply (a FOUNDATION fieldbus Power Supply Module) must be capable of providing at least 14 mA for each transmitter connected.

A summary of the voltage requirements is listed in Table 15.

Table 15. Minimum Supply Voltage Requirements

Minimum Supply Voltage	9 V
Recommended Supply Voltage	24 V
Maximum Supply Voltage	32 V

The transmitter is equipped with an internal ground connection within the field wiring compartment and an external ground connection at the base of the electronics housing. To minimize galvanic corrosion, place the wire lead or terminal between the captive washer and loose washer on the external ground screw. Ground the shield at one place per segment **only**.

Refer to Figure 42 for wiring diagram.

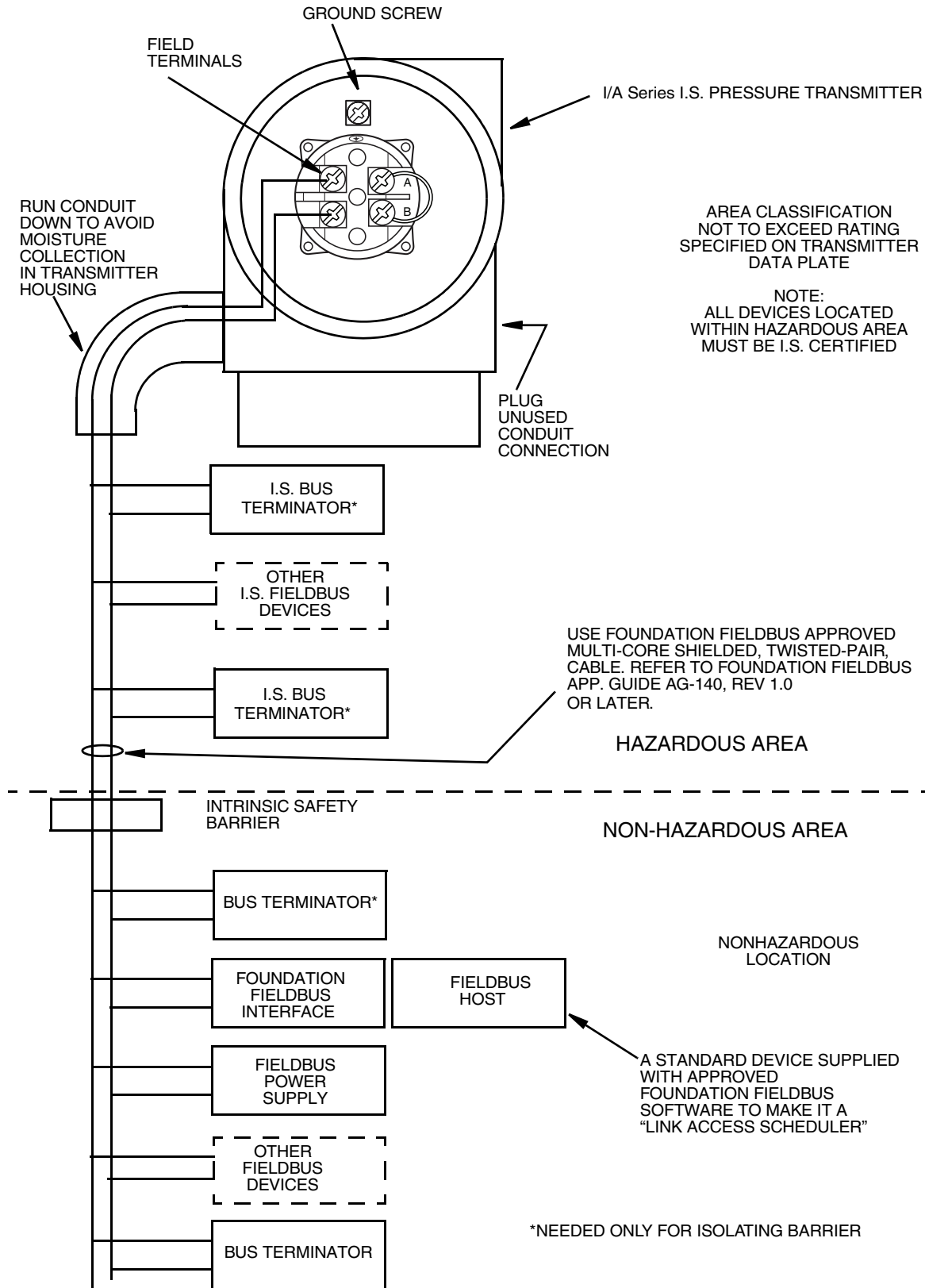

Figure 42. Wiring Diagram of Typical FOUNDATION Fieldbus Transmitter Installation

Installing Fieldbus Software (Model Code -F)

Device descriptions for I/A Series Foundation fieldbus transmitters are available for downloading from the website

<http://ips.invensys.com/en/products/measurement/Pages/downloads-P076.aspx>

The files are:

Filename	Description
xxyy.ffo	DD binary file
where	xx = Device Rev. (Parameter 12 in Resource Block) yy = DD Rev. (Parameter 13 in Resource Block)
xxyy.sym	DD symbol file
xxyyzz.cff	Capability file (zz = cff rev)

Set up the following directory structure for the DD files of a device on the host computer. According to the FOUNDATION specification, the device description files must be present in the appropriate directories as described below.

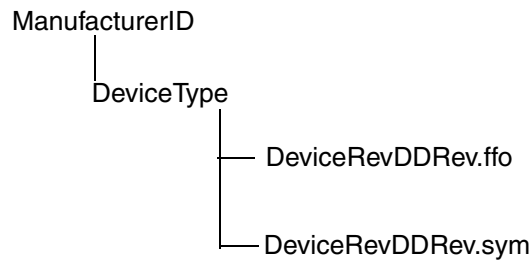

where *.ffo is the DD binary file and *.sym is the symbol file.

The Manufacturer ID for Foxboro is 385884 and the Device Type for this transmitter is BA30.

Putting a Differential Pressure Xmtr Into Operation

The following procedure explains how to sequence the valves in your flow measurement piping or optional bypass manifold to ensure that your transmitter is not overranged and that seal liquid is not lost. Refer to Figure 23 or Figure 24.

— **NOTE** —

Procedure assumes that Process shutoff valves are open.

1. Make sure that both upstream and downstream manifold valves are closed.
2. Make sure that bypass valve is open.
3. Slowly open the upstream manifold valve.
4. Close the bypass valve.
5. Slowly open the downstream manifold valve.

Taking a Differential Pressure Xmtr Out of Operation

The following procedure explains how to sequence the valves in your flow measurement piping or optional bypass manifold to ensure that your transmitter is not overranged and that seal liquid is not lost. Refer to Figure 23 or Figure 24.

— **NOTE** —

Procedure assumes that Process shutoff valves are open.

1. Close the downstream manifold valve.
2. Close the upstream manifold valve.
3. Open the bypass valve.
4. Carefully open the vent screw to release any residual pressure before disconnecting lines.

—  **WARNING** —

When venting pressure from the transmitter, wear suitable protective equipment to prevent possible injury from process material, temperature, or pressure.

3. Operation Using Local Display

— **NOTE** —

For analog output versions (electronics codes -A or -V), all configuration must be done from the optional local display. For intelligent versions (electronics codes -D, -T, and -F), you can configure most parameters using the local display. However, for more complete configuration capability, use a PC-Based Configurator or HART Communicator.

A local display, as shown in Figure 43, has two lines of information. The upper line is a 5-digit numeric display (4-digit when a minus sign is needed and 4-digit for electronics versions -A and -V); the lower line is an 7-digit alphanumeric display. The display provides local indication of measurement information. The primary (M1) measurement is normally displayed. To view the secondary (M2) measurement on intelligent versions, press the **Enter** button while in normal operating mode. Press the **Next** or **Enter** button to return to the primary measurement. If left in M2 display, an M2 message blinks in the lower right of the display. If power to the transmitter is interrupted, the display reverts to the M1 display.

— **NOTE** —

With HART communication, the display can be configured to meet your specific needs. If configured **Show 1**, M1 is displayed. If configured **Show 2**, M2 is displayed. To temporarily view the alternate measurement, press the **Enter** button. After showing this measurement for a brief period, the display reverts to the configured display. If configured **Toggle**, the display toggles between M1 and M2. When M2 is displayed, an M2 message blinks in the lower right of the display. If power to the transmitter is interrupted, the display reverts to the configured display.

The display also provides a means for performing calibration and configuration, viewing the database, and testing the display via the 2-button keypad. You can access these operations by means of a multi-level menu system. Entry to the Mode Select menu is made (from normal operating mode) by pressing the **Next** button. You can exit this menu, restore your prior calibration or configuration, and return to the normal operating mode at any time by going to **Cancel** and pressing the **Enter** button.

— **NOTE** —

During calibration or configuration, if an entry is **Entered** in error, use the **Cancel** feature to restore the transmitter to its starting configuration and begin again.

The following items can be selected from this menu: Calibration (**CALIB**). Configuration (**CONFIG**), Viewing the database (**VIEW DB**), and Testing the display (**TST DSP**). The top level structure diagram is shown in Figure 44.

— **NOTE** —

VIEW DB is not applicable to Code -A and -V transmitters.

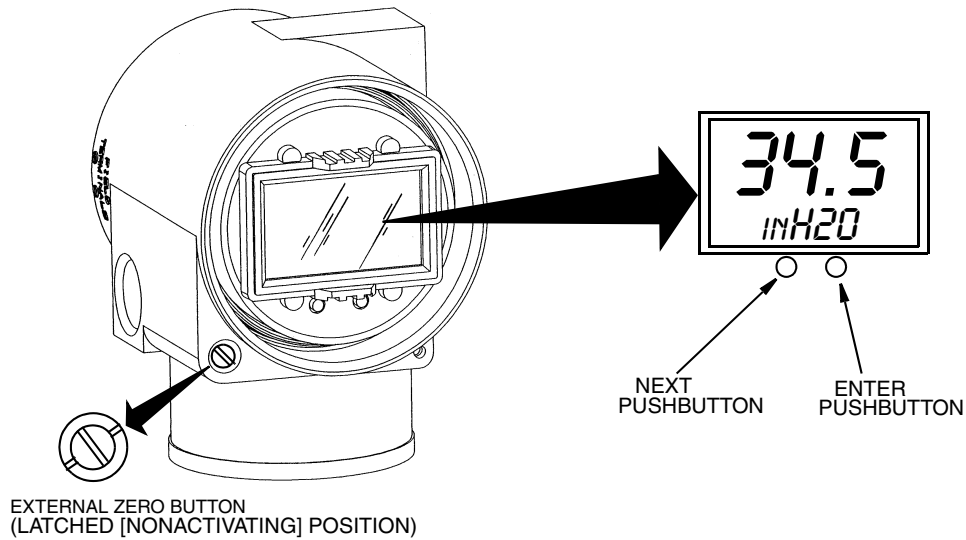
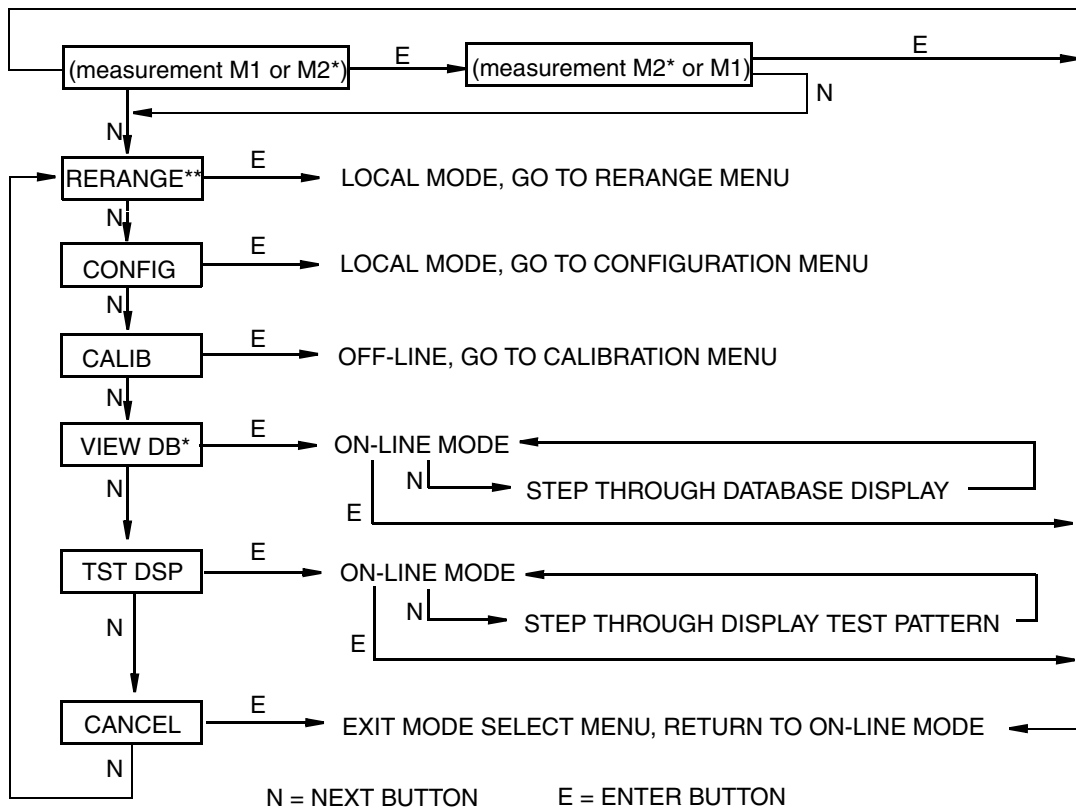

Figure 43. Local Display Module



*M2 AND VIEW DB NOT APPLICABLE TO MODEL CODE -A AND -V TRANSMITTERS

**RERANGE ONLY APPLICABLE TO MODEL CODE -T TRANSMITTERS

Figure 44. Top Level Structure Diagram

— NOTE

In the Configuration menu and during adjustment of 4 and 20 mA (or 1 to 5 V dc) in the Calibration menu, the milliampere (or voltage) output does not reflect live measurement values. Also, during Calibration and Configuration menu operations, the I/A Series system identifies all transmitter measurements as **BAD** because the transmitter is not in the online mode.

Moving Through the Menu Structure

The general procedure for moving through the menu structure is to use the **Next** button to select an item and the **Enter** button to specify your selection. See Figure 45 for an example of a typical menu structure. The example used is the beginning of the Configuration menu for a transmitter with FoxCom Communications.

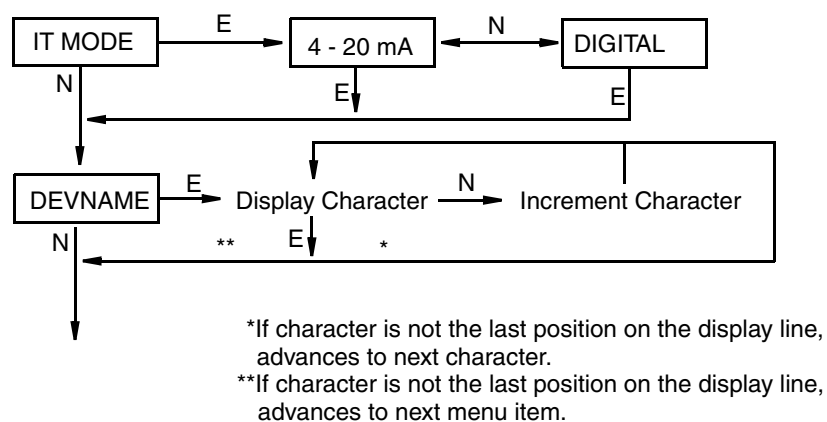

Figure 45. Typical Menu Structure

In Figure 45, at the display **IT MODE**, press **Enter**. Use the **Next** button to select **4-20 mA** or **Digital** and then **Enter** to specify your selection. The display advances to **DEVNAME**. Press **Enter**. Follow the general procedure below to select the letters for your device name. The procedure to enter letters is similar to that for entering numerical values.

Entering Numerical Values

The general procedure for entering numerical values in Calibration and Configuration is as follows:

1. At the appropriate prompt press the **Enter** button. The display shows the last (or default) value with the first digit flashing.
2. Use the **Next** button to select the desired first digit, then press the **Enter** button. Your selection is entered and the second digit flashes.
3. Repeat Step 2 until you have created your new value. If the number has less than five characters, use leading or trailing zeros for the remaining spaces. When you have configured the fifth space, the display prompts you to place the decimal point (**SET DP**).
4. Move the decimal point with the **Next** button until it is where you want it and press the **Enter** button.

5. The display advances to the next menu item.

— **NOTE**

1. The decimal point may not be placed directly after the first digit. For example, you can not enter a value as 1.2300; you must enter it as 01.230.
 2. The decimal position is identified by flashing except at the position after the fifth digit. At that position (representing a whole number), the decimal point is assumed.
-

Zeroing from the LCD Indicator Pushbuttons or Optional External Zero Button

Depending on the electronics version specified and whether or not the optional external zero adjust is specified, the transmitter can be zeroed with either the Lower Range Value pressure applied (CAL LRV) or zero pressure applied (CAL AT0).

The value of LRV pressure is settable and stored in the transmitter database. Apply a pressure equal to this value before activating CAL LRV.

CAL AT0 allows easy zeroing of transmitters with non-zero based ranges. Before activating CAL AT0, gauge pressure transmitters must be vented to atmosphere and differential pressure transmitters must have zero differential pressure applied. Do **not** use CAL AT0 with remote seal transmitters having seals at different elevations from the transmitter or with vented absolute pressure transmitters.

The following table shows the zeroing functions supported by each electronics version.

Interface Method	Electronics Versions	
	D, F, and T	A and V
LCD Pushbuttons ^(a)	CAL LRV and CAL AT0	CAL LRV and CAL AT0
External Zero Option ^(b)	CAL LRV and CAL AT0	CAL AT0

(a)Function selected from CALIB menu on LCD Indicator.

(b)On transmitters with Dual Function External Zero (Versions -D, -F, and -T), the zeroing is done by depressing the zero button:

- < 3 seconds = CAL AT0
- > 5 seconds = CAL LRV

Using the Optional External Zero Button:

An external zero adjustment mechanism in the electronics housing (see Figure 43) allows zeroing without removing the electronics compartment cover.

Zeroing is accomplished by depressing the zero button after it is unlatched.

Unlatch the zero button by turning the screw 90° counterclockwise so that the screwdriver slot lines up with the two holes in the face of the adjacent part. Do not push the button in with the screwdriver until ready to perform the zeroing operation.

Zeroing from a HART Communicator

The electronics version -T transmitter can be zeroed from a HART Communicator. The transmitter can be zeroed with any applied pressure by entering the value of the applied pressure (one-point calibration).

Also, using the Zero Trim function on the HART Communicator provides the same function as a CAL AT0. To do this, the following requirements apply:

- ◆ Differential Pressure Transmitter H and L sides must be equalized
- ◆ Gauge Pressure Transmitter Must be vented to atmosphere
- ◆ Absolute Pressure Transmitter Full vacuum must be applied

— **NOTE** —

Do **not** perform a Zero Trim procedure on an absolute pressure transmitter unless full vacuum is applied. The more common procedure for zeroing an absolute pressure transmitter is to vent it to atmosphere and do a one-point calibration, entering the current value of barometric pressure.

4. Calibration

Calibration Diagram

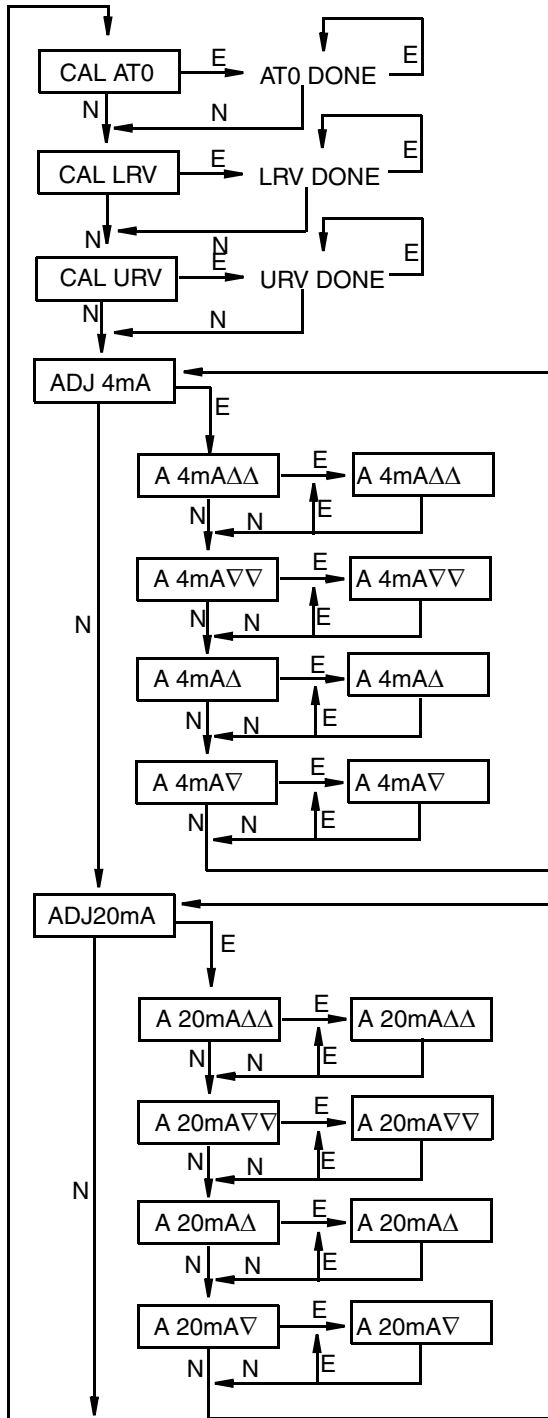

E = ENTER
N = NEXT

NOTES:

1. CAL AT0, CAL LRV, and CALURV apply to transmitters with FoxCom communications (Code -D), HART communications (Code -T), 4 to 20 mA Output (Code -A), and 1 to 5 V dc Output (Code -V).
2. For Code -V transmitters, substitute 1 V dc for 4 mA and 5 V dc for 20 mA throughout the diagram.
3. This diagram does **not** apply to transmitters with FOUNDATION fieldbus communication (Code -F). For calibration information on these transmitters, see the CD-ROM.
4. **CAL AT0, CAL LRV, and CAL URV require application of appropriate pressure before pressing ENTER. For reranging without pressure, see the next page.**

(continued on Figure 47)

Figure 46. Calibration Structure Diagram

(continued from Figure 46)

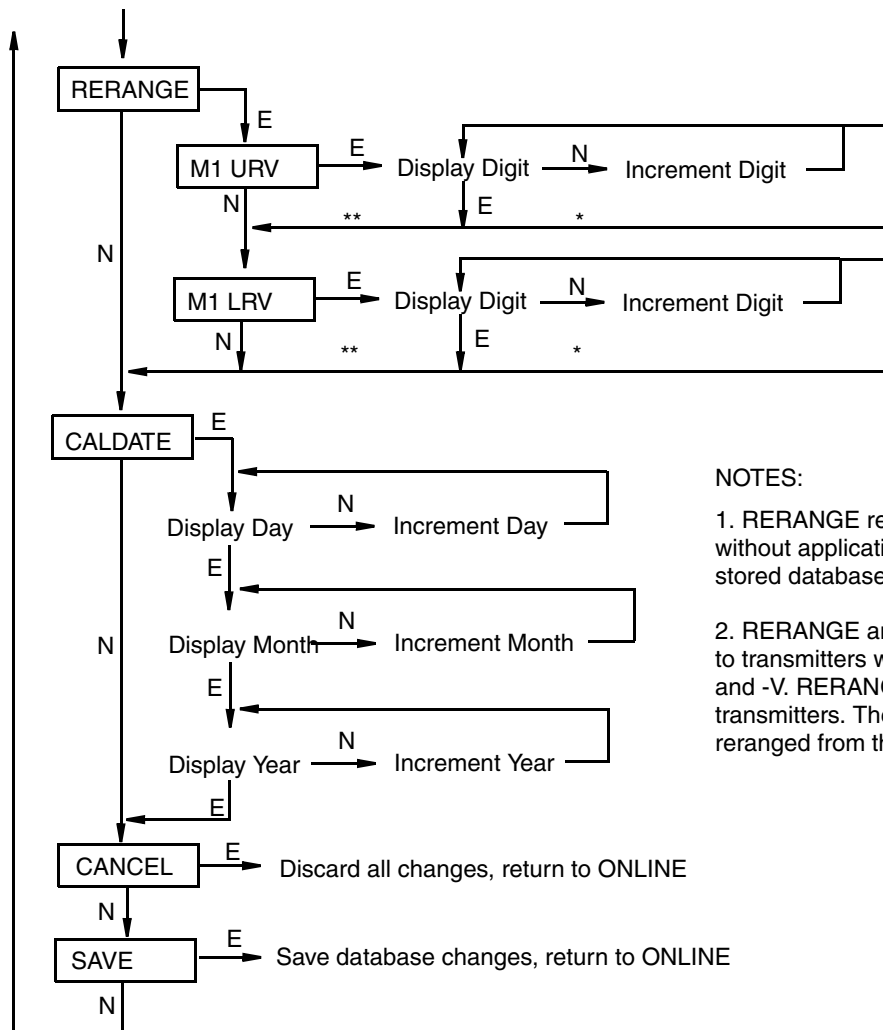

NOTES:

1. RERANGE refers to changing the range without application of pressure. It changes stored database values.

2. RERANGE and CALDATE does **not** apply to transmitters with electronics versions -A and -V. RERANGE also does **not** apply to -T transmitters. These transmitters can be reranged from the top level menu.

*If character is not the last position on the display line, advances to next character.
 **If character is the last position on the display line, advances to next menu item.

Figure 47. Calibration Structure Diagram (Continued)

Liquid Level Application Calibrated Range Values

Use the following to determine the upper and lower range values for Liquid Level applications. For similar information on Liquid Density or Liquid Interface Level applications, refer to MI 020-369 on the CD-ROM with your transmitter.

The level range is a function of measured liquid head. The measurement may be in equivalent head of water units, such as inH₂O or mmH₂O. However, the numerical value in level units may be very different from the numerical value in equivalent head of water units. For example, a wet leg application may have a transmitter measurement range of -140 to -20 inH₂O for a desired level measurement range of 0 to 150 inches.

The following illustrations show how to calculate the typical measurement ranges for various tank applications.

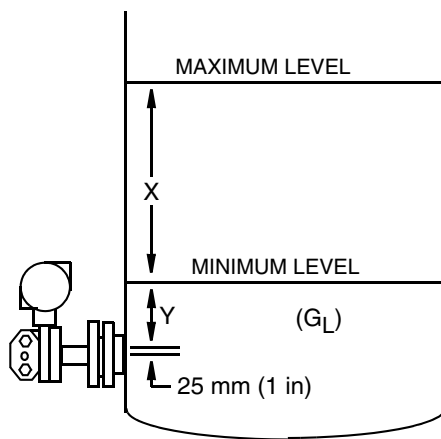

$$\begin{aligned}\text{Span} &= (X)(G_L) \\ \text{LRV} &= (Y)(G_L) \\ \text{URV} &= (X+Y)(G_L) \\ \text{Range} &= \text{LRV to URV}\end{aligned}$$

where:

X and Y are in the same units, such as in or mm
 G_L = Specific gravity of the tank liquid
 LRV = Lower Range Value at minimum level
 URV = Upper Range Value at maximum level
 LRV and URV are in units of Equivalent Head of Water, such as inH₂O or mmH₂O

Figure 48. Transmitter Connected to Open Tank

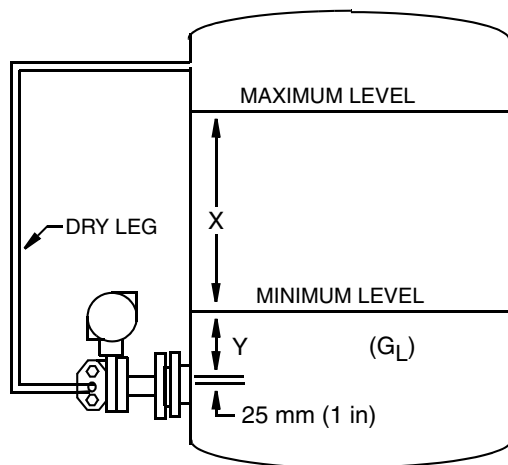

$$\begin{aligned}\text{Span} &= (X)(G_L) \\ \text{LRV} &= (Y)(G_L) \\ \text{URV} &= (X+Y)(G_L) \\ \text{Range} &= \text{LRV to URV}\end{aligned}$$

where:

X and Y are in the same units, such as in or mm
 G_L = Specific gravity of the tank liquid
 LRV = Lower Range Value at minimum level
 URV = Upper Range Value at maximum level
 LRV and URV are in units of Equivalent Head of Water, such as inH₂O or mmH₂O

Figure 49. Transmitter Connected to Closed Tank with Dry Leg

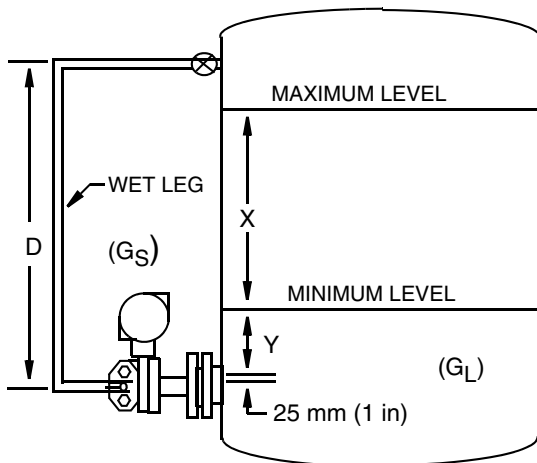

$$\begin{aligned}\text{Span} &= (X)(G_L) \\ \text{LRV} &= Y(G_L) - D(G_S) \\ \text{URV} &= (X+Y)(G_L) - D(G_S) \\ \text{Range} &= \text{LRV to URV}\end{aligned}$$

where:

X, Y, and d are in the same units
 LRV = Lower Range Value at minimum level
 URV = Upper Range Value at maximum level
 LRV and URV are in units of Equivalent Head of Water, such as inH₂O or mmH₂O
 G_L = Specific gravity of the tank liquid
 G_S = Specific Gravity of the capillary fill fluid

Figure 50. Transmitter Connected to Closed Tank with Wet Leg

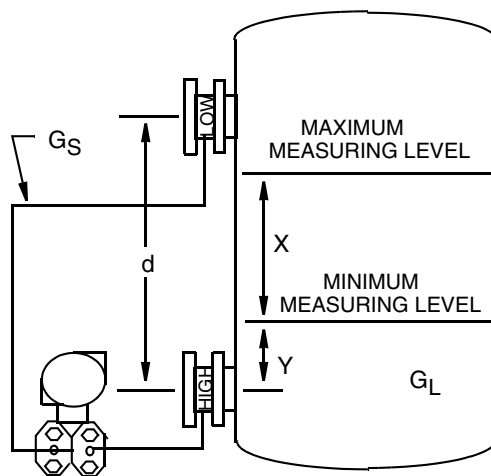

$$\begin{aligned}\text{Span} &= (X)(G_L) \\ \text{LRV} &= (Y)(G_L) - (d)(G_S) \\ \text{URV} &= (Y + X)(G_L) - (d)(G_S) \\ \text{Range} &= \text{LRV to URV}\end{aligned}$$

where:

X, Y, and d are in the same units
 LRV = Lower Range Value at minimum level
 URV = Upper Range Value at maximum level
 LRV and URV are in units of Equivalent Head of Water, such as inH₂O or mmH₂O
 G_L = Specific gravity of tank liquid
 G_S = Specific Gravity of capillary fill fluid

Silicone (DC200, 10 cSt):	0.94
Fluorinert (FC77):	1.76
Silicone (DC200, 3 cSt):	0.89
Silicone (DC704):	1.07
Neobee:	0.92

Figure 51. Transmitter Connected to Closed Tank With Dual Seals

There are several methods that can be used to set up the transmitter for liquid level applications. These methods assume:

- ◆ The installation is complete, including any dry legs, wet legs (filled), and any seals are in place.
- ◆ The "zero level reference" is at or above the bottom pressure tap.
- ◆ The electronics have a 4 to 20 mA output (Analog) or 4 to 20 mA + digital output (HART or FoxCom).

Method #1 - Calculating the range values

- ◆ This method relies on calculations only, so it can be used when there is no liquid in the tank yet or if there is liquid but at an unknown level.
- ◆ The 4 & 20 mA output points correspond to the calculated LRV and URV. Because the 4 to 20 mA signal is reranged to the entered LRV and URV, the transmitter calibration is unaffected.
- ◆ The local indicator, if present, can be set up to display 0 to 100%.
- ◆ If not configured for percent, the indicator will display the measured pressure, not the level. This is a drawback if you want to have the display read in level units (m, mm, in, or ft).
 - ◆ If you use a FoxCom transmitter, it supports custom units that can be used to display level.
 - ◆ If you have a HART or Analog transmitter, you can use a pressure unit such as mmH₂O or ftH₂O to simulate mm or ft, if the specific gravity of the liquid is 1 or close enough to 1 to meet the required accuracy for display. Also, this requires that the minimum level point correspond to the elevation of the transmitter and it only applies to open tanks and closed tanks with a dry leg.

Procedure for Method #1

Set LRV and URV equal to the calculated values.

Method #2 - Using the Transmitters to Determine the Range Values

- ◆ This method uses the transmitter to determine the LRV and URV rather than having to calculate the values. It also has the advantage of zeroing the transmitter to account for minor installation tilt. However it requires the ability to change the liquid level in the tank to known points (minimum level corresponding to LRV and maximum level corresponding to URV).
- ◆ If the level can be put at the point corresponding to LRV but cannot be brought up to the point corresponding to URV, this method can also be used to automatically determine the LRV. Then the span can be calculated from the equations shown above and added to the LRV to determine URV for manual entry into the transmitter database. This variation on Method #2 can also be used when there is no liquid in the tank if the minimum level point is to be at the elevation of the bottom tap.
- ◆ The local indicator, if present, can be set up to display 0 to 100%.
- ◆ If not configured for percent, the indicator will display the measured pressure, not the level. This is a drawback if you want to have the display read in level units (m, mm, in, or ft).
 - ◆ A FoxCom transmitter supports custom units that can be used to display level.
 - ◆ A HART or Analog transmitter can use a pressure unit such as mmH₂O or ftH₂O to simulate mm or ft, if the specific gravity of the liquid is 1 or close enough to 1 to meet

the required accuracy for display. However, this requires that the minimum level point correspond to the elevation of the transmitter and it only applies to open tanks and closed tanks with a dry leg.

Procedure for Method #2

- ◆ For HART transmitters, using a HART Communicator having the appropriate DD installed, use the function "Rerange with Applied Pressure" when the liquid is at the minimum level point.
If the level can be raised to the maximum level, use "Rerange with applied pressure" for URV when the level is at the maximum point in the tank. If it is not practical or possible to raise the level to the maximum point, read the LRV that has been automatically entered and manually set $URV = LRV + \text{Span}$.
- ◆ For FoxCom and Analog transmitters, record the pressure reading at the minimum level point and enter it into the database for the LRV. Then, determine URV the same way or by adding the calculated span value to LRV.

Method #3 - Getting the Local Indicator and Transmitted Value to Indicate Level - HART Transmitters

- ◆ When using a pressure unit, for example inH₂O or mmH₂O, to indicate level (liquids with SG =1), if the transmitter is not at the elevation corresponding to minimum level or if there is a wet leg or dual seals, the offset function can be used to have "zero" correspond to any desired level point regardless of the liquid head on the high or low side of the transmitter at that point.
- ◆ This does not affect the calibration of the transmitter.
- ◆ This offset procedure may be used for FoxCom transmitters but it is not required because custom units can be used.

Procedure for Method #3

- ◆ Even if the calculated LRV is not 0, set $LRV = 0$ and set $URV = \text{Span}$ (calculated).
- ◆ With the level at the minimum level measurement point in the tank, read and record the pressure value displayed on the local indicator (if present) or the pressure value read from a HART Communicator.
- ◆ Enter this value for the M1EOFF parameter (called PV Offset if using a HART Communicator). Maintain the sign; that is, if the value is negative, enter it as a negative value.
- ◆ This procedure zeroes the transmitter and sets the 4 and 20 mA points corresponding to minimum and maximum level, respectively. The 20 mA point is based on the calculated span.
- ◆ If the liquid has the same density as water, the equivalent head of water units such as inH₂O or mH₂O can be used to represent the level in inches or meters on the local display or HART Communicator.

Method #4 - Getting the Local Indicator and Transmitted Value to Indicate Level - Analog Output Transmitters

- ◆ The analog output transmitters do not have the offset function described above. Use this method if you want to use a pressure unit to indicate level when the pressure is not zero at minimum level, such as when a wet leg or dual seal is used. The liquid must have the same density as water in order to use equivalent head of water units such as inH₂O to indicate inches of level.

Procedure for Method #4

- ◆ Even if the calculated LRV is not 0, set LRV = 0 and set URV = Span (calculated).
- ◆ With the level at the minimum level measurement point in the tank, zero the transmitter as if it had zero pressure on it (CAL ATO) using the local display). This procedure zeroes the transmitter and sets the 4 and 20 mA points corresponding to minimum and maximum level, respectively. The 20 mA point is based on the calculated span.
- ◆ The measured and indicated pressure at the minimum level measurement point is zero.
- ◆ This method shifts the calibration and is not suitable if the offset is greater than 50% of the maximum span limit for the selected transmitter. For example, if the range is -140 to -20 inH₂O, the transmitter would have to be a 'C' span or greater for this method to work. The maximum span of a 'B' sensor is 200 inH₂O and 50% of that is 100 inH₂O. Since the absolute value of the LRV in our example (140 inH₂O) is more than 100 inH₂O, a 'B' sensor would not work. However since the maximum span of a 'C' sensor is 840 inH₂O and 50% of that is 420 inH₂O, it would work.

5. Configuration Diagrams

FoxCom Communications (Code -D)

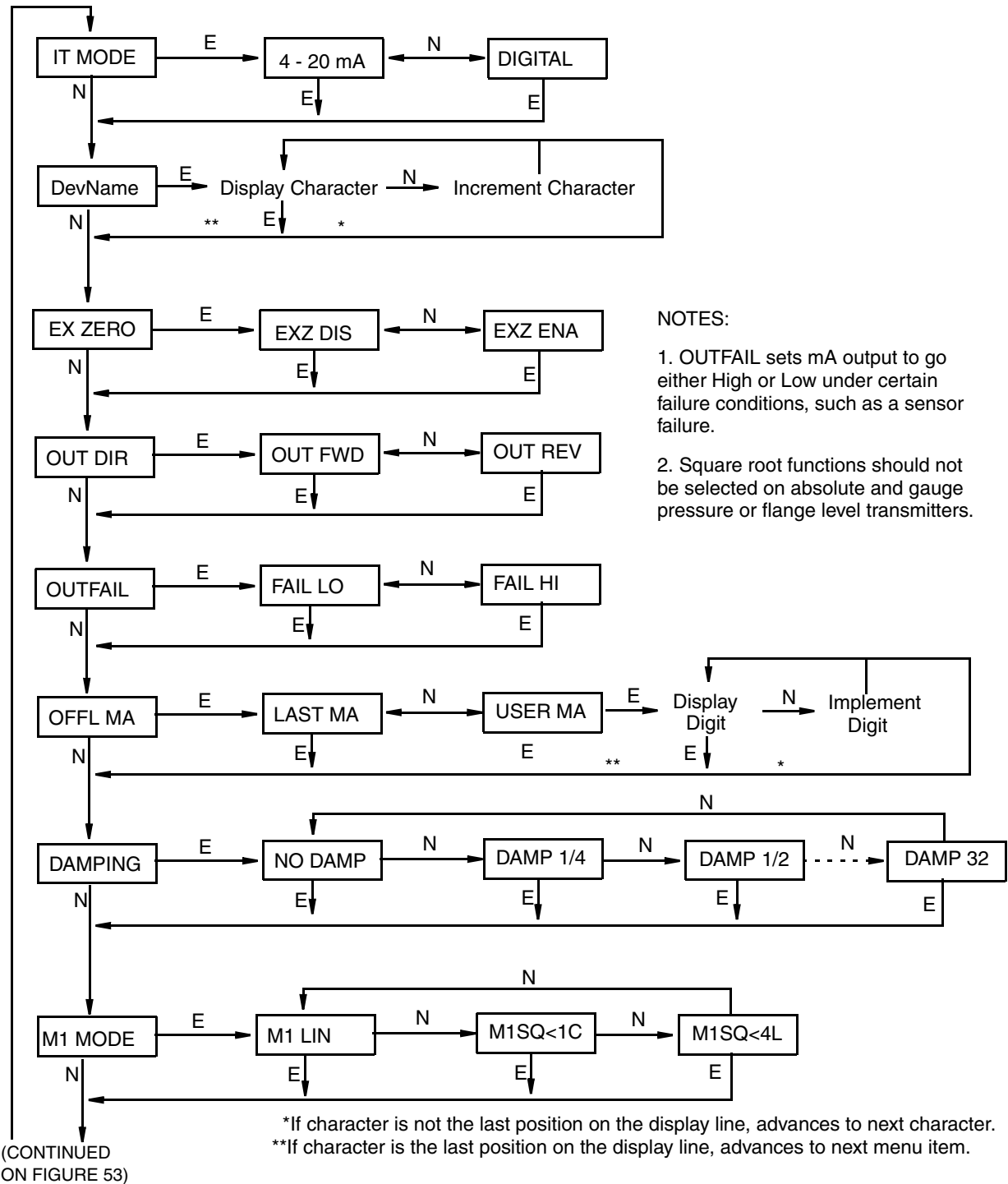
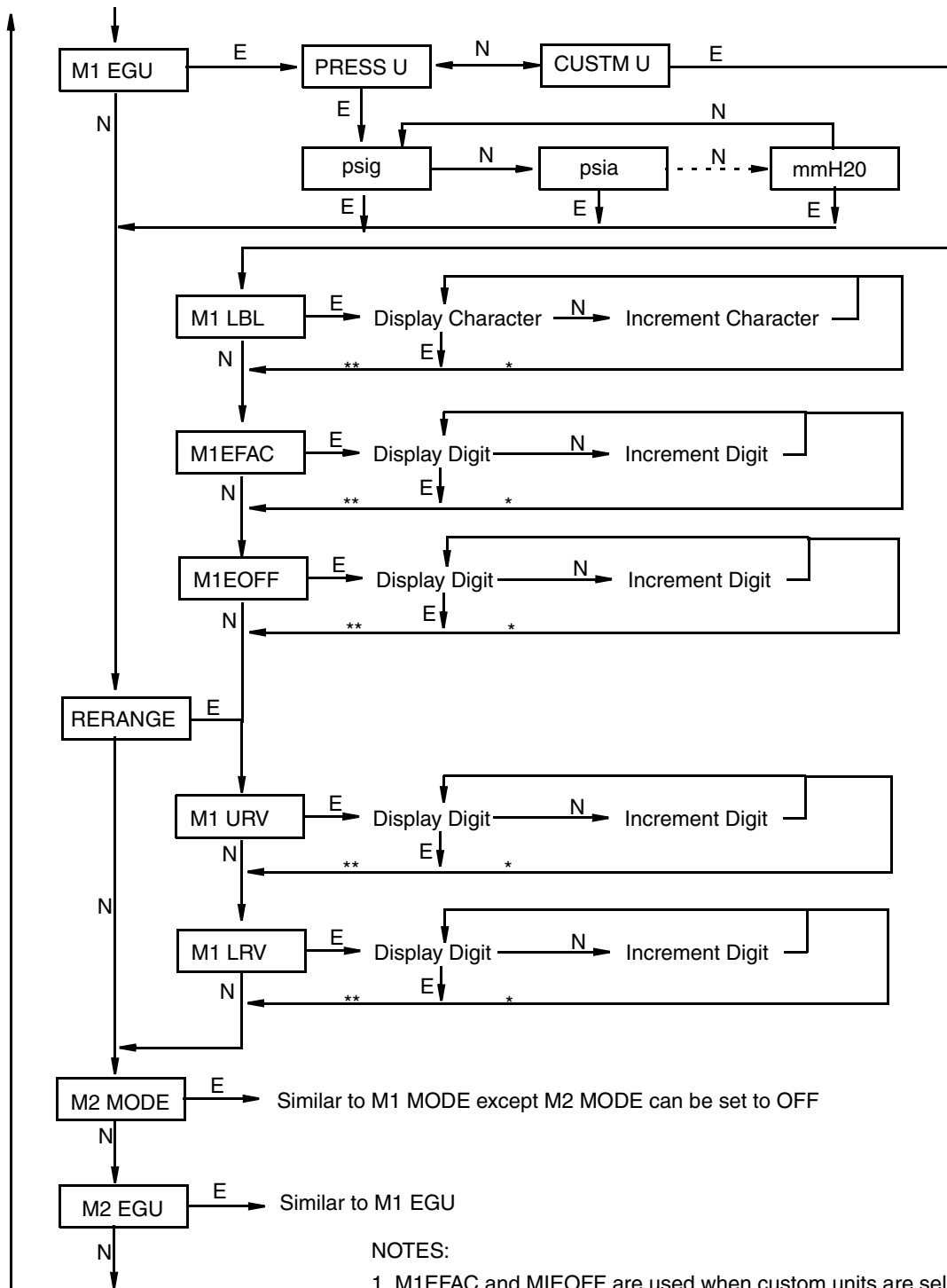

Figure 52. FoxCom Configuration Structure Diagram

(CONTINUED FROM FIGURE 52)



(CONTINUED ON FIGURE 54)

NOTES:

1. M1EFAC and M1EOFF are used when custom units are selected, in order to establish the LRV and URV in the custom units.
2. Percent Output is selectable CUSTM U.

*If character is not the last position on the display line, advances to next character.
 **If character is the last position on the display line, advances to next menu item.

Figure 53. FoxCom Configuration Structure Diagram (Continued)

(CONTINUED FROM FIGURE 53)

NOTES:

1. If configuring passwords, use care to record the password. Password protection applies to the pushbuttons.
2. The CLEAR DB function in SET GDB should not be selected unless a non-recoverable error condition exists. It resets the database to default values, losing all user calibration and configuration settings. Reconfiguration and recalibration will be required.

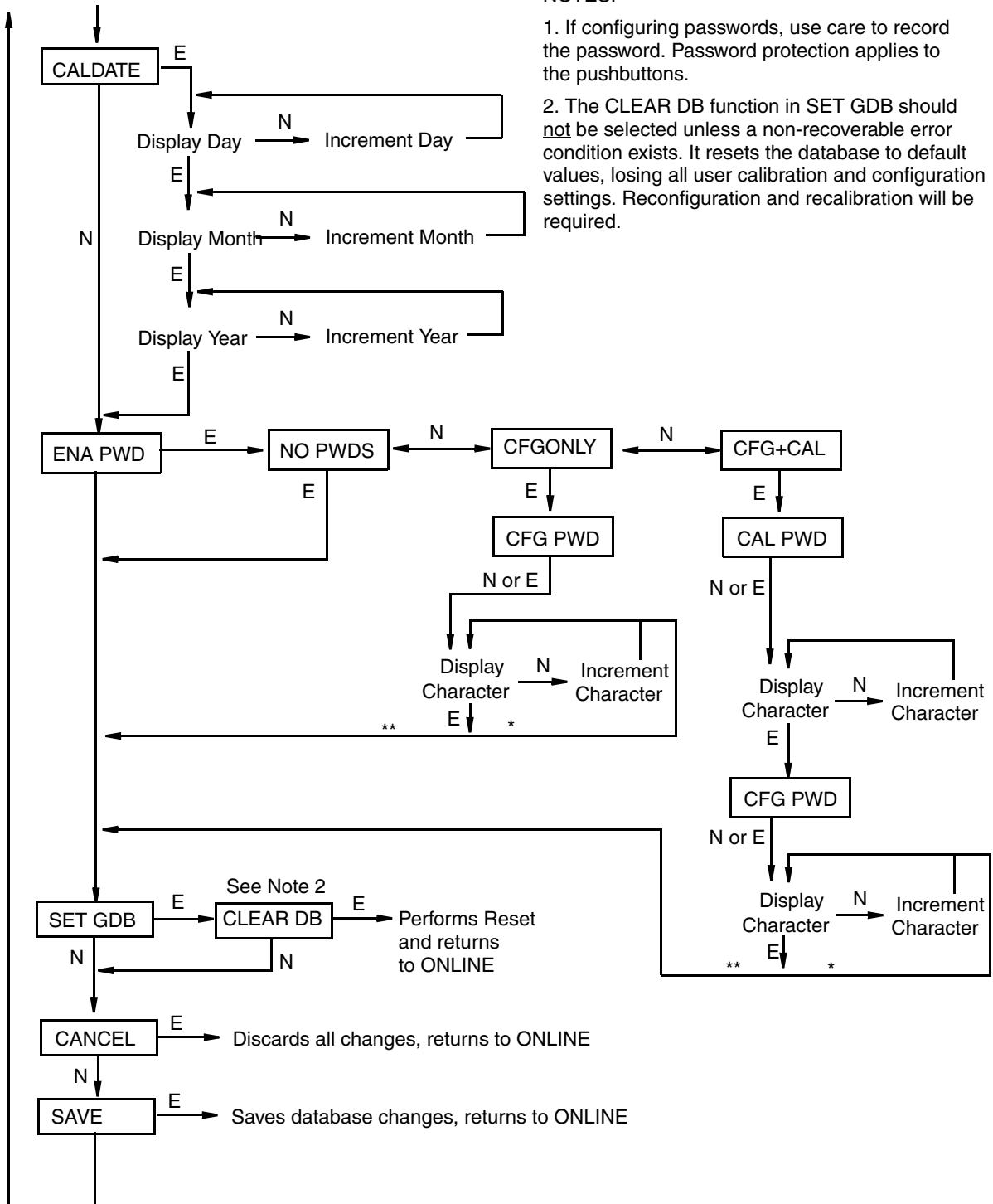

*If character is not the last position on the display line, advances to next character.
 **If character is the last position on the display line, advances to next menu item.

Figure 54. FoxCom Configuration Structure Diagram (Continued)

HART Communications (Code -T)

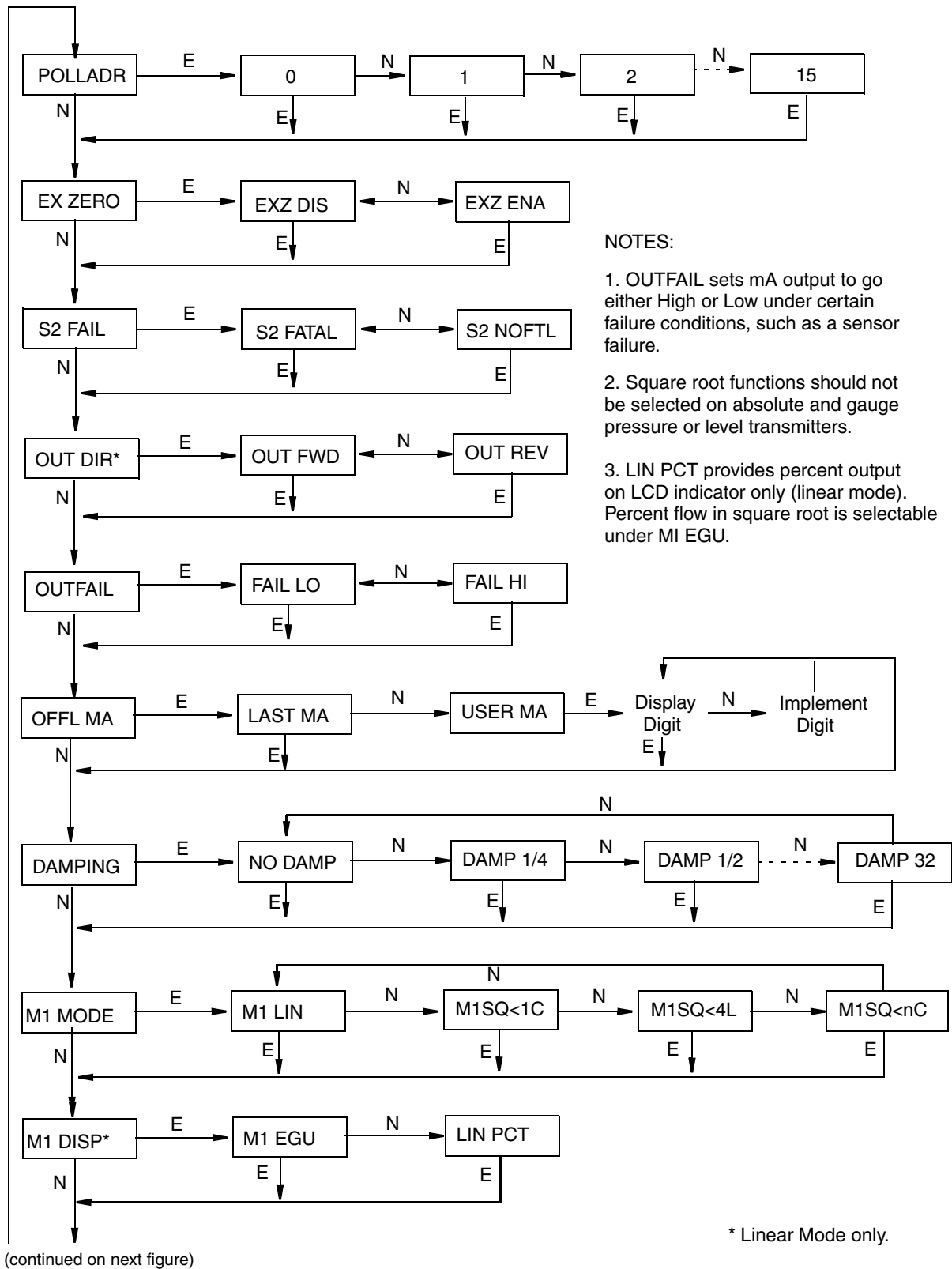
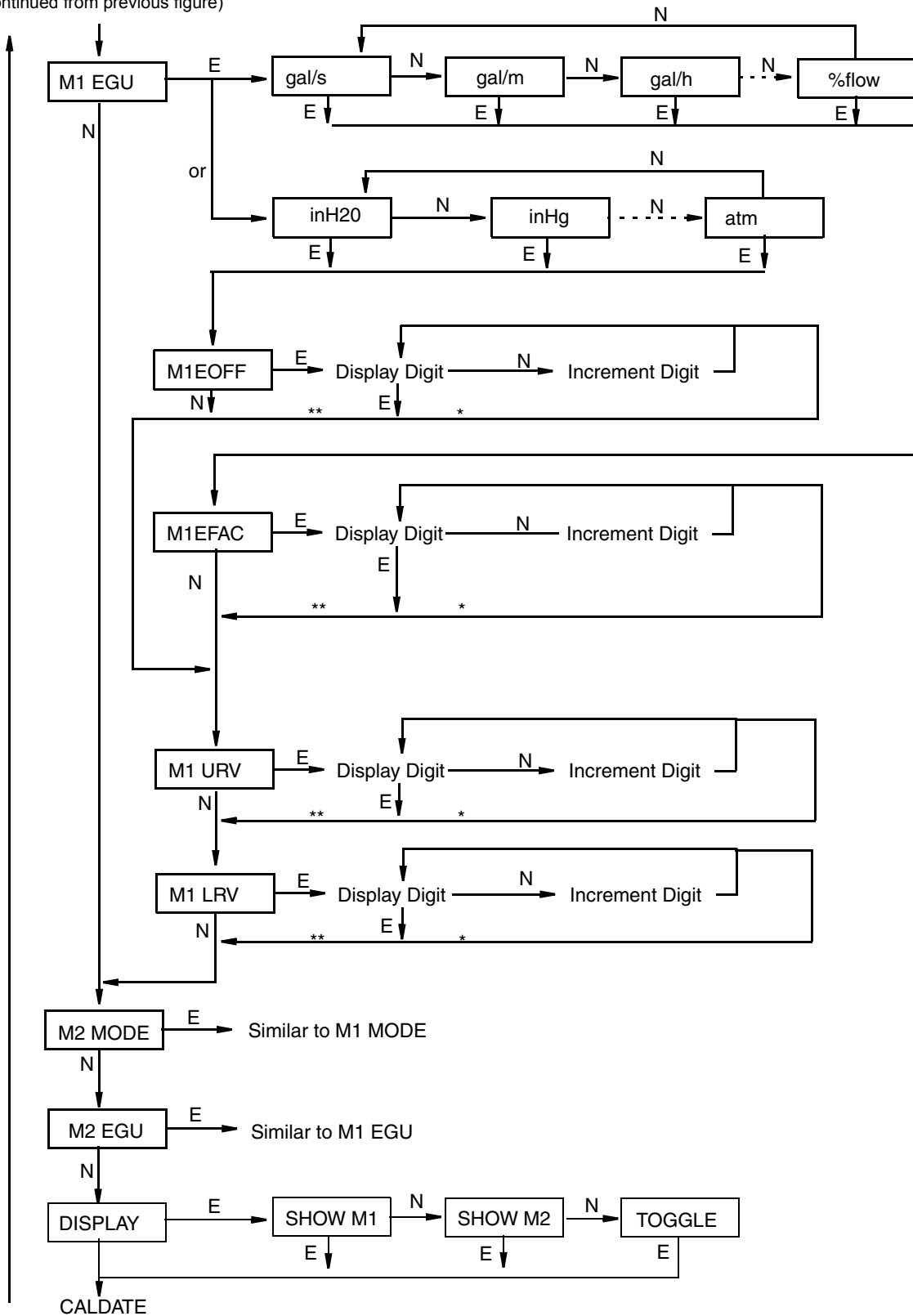

Figure 55. Configuration Structure Diagram

(continued from previous figure)



(continued on next figure)

*If character is not the last position on the display line, advances to next character.
 **If character is the last position on the display line, advances to next menu item.

Figure 56. Configuration Structure Diagram (Continued)

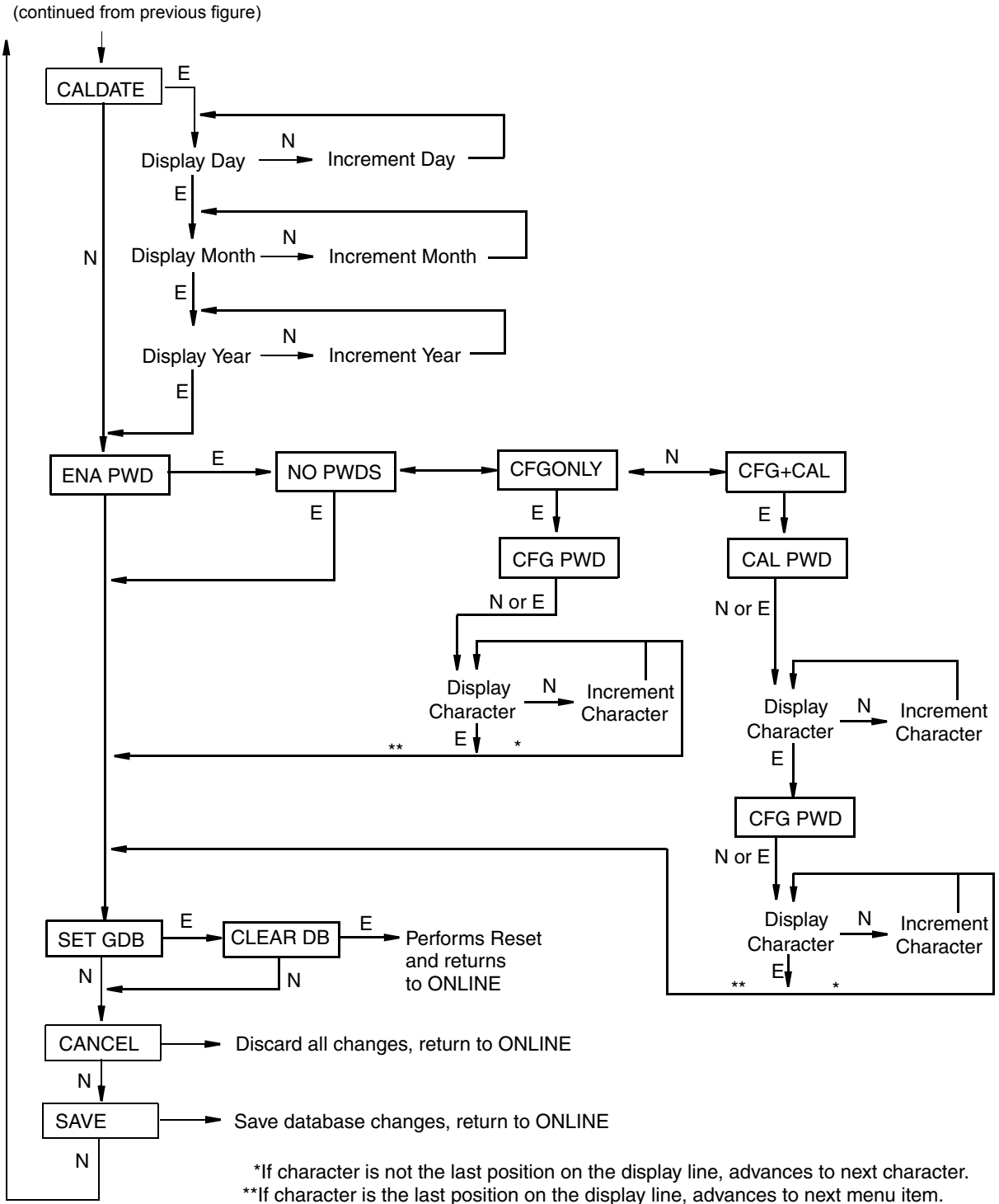

Figure 57. Configuration Structure Diagram (Continued)

FOUNDATION Fieldbus Communications (Code -F)

Refer to the CD-ROM with your transmitter.

4 to 20 mA (Code -A) and 1 to 5 V dc (Code -V)

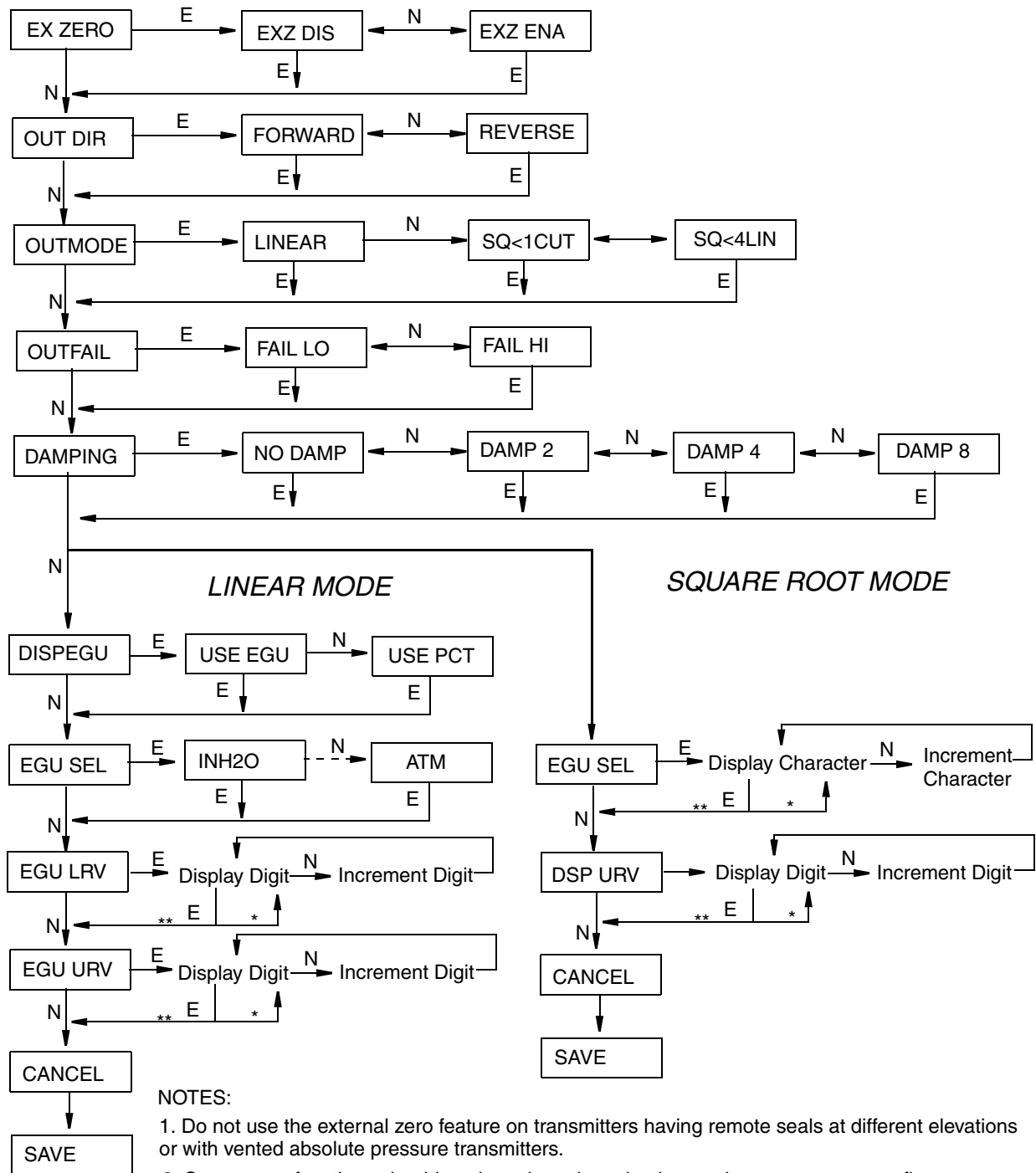

Figure 58. Configuration Structure Diagram (Code -A and -V)

Index

A

Absolute Pressure Transmitter Mechanical Installation 31

C

Calibration Diagram 57

Configuration Diagrams 65

Cover Locks 36

D

Differential Pressure Transmitter

 Mechanical Installation 19

 Putting into Operation 50

 Taking Out of Operation 50

E

Entering Numerical Values 53

F

Fieldbus Software, Installing 49

Foundation fieldbus Communication, Wiring for 47

FoxCom Communications Protocol, Wiring for 45

G

Gauge Pressure Transmitter Mechanical Installation 31

H

HART Multidrop Wiring 41

L

Liquid Level Application Calibrated Range Values 58

Local Display 51

M

Mechanical Installation 19

Menu Structure, Moving through the 53

P

Pipe Mounting 22
 Positioning Housing 35
 Positioning Optional Display 35

S

Safety Information 1

W

Wiring 36
 1 to 5 V dc Output Signal 42
 4 to 20 mA Output Signal 37
 Foundation Fieldbus Communication 47
 FoxCom Communications Protocol 45
 HART Multidrop 41
 Write Protect Jumper, Setting the 35

Z

Zeroing 54

ISSUE DATES

JAN 2000	MAR 2007	AUG 2010
APR 2002	MAY 2009	
SEP 2003	MAY 2010	
NOV 2004	JUN 2010	

Vertical lines to the right of text or illustrations indicate areas changed at last issue date.

Invensys Operations Management
 5601 Granite Parkway Suite 1000
 Plano, TX 75024
 United States of America
<http://www.iom.invensys.com>

Global Customer Support
 Inside U.S.: 1-866-746-6477
 Outside U.S.: 1-508-549-2424 or contact
 your local Invensys representative.
 Email: support@invensys.com
 Website: <http://support.ips.invensys.com>

Invensys, Foxboro, and I/A Series are trademarks of
 Invensys plc, its subsidiaries, and affiliates.
 All other brand names may be trademarks of their
 respective owners.

Copyright 1999-2010 Invensys Systems, Inc.
 All rights reserved