

Model 876CR Intelligent Transmitter for Contacting Conductivity and Resistivity Measurements with HART Communication Protocol



The Foxboro[®] brand Model 876CR is a 2-wire loop powered intelligent transmitter that, when used with an appropriate electrochemical sensor, provides measurement, local display, and transmission of contacting conductivity, resistivity, or concentration. The transmitter outputs a HART digital signal and a 4 to 20 mA analog output.

FEATURES

- ▶ 4 to 20 mA output with a HART⁽¹⁾ digital signal.
- ▶ Temperature prediction⁽²⁾
- ▶ Remote configuration/calibration with the HART Communicator or PC-based Configurator.
- ▶ Local configuration with the keypad on the integral local human interface.
- ▶ LCD indicator can display either one, two, or three measurement variables.
- ▶ Fault isolation to transmitter or sensor.
- ▶ Galvanically isolated output.
- ▶ Continuous transmitter/sensor diagnostics.
- ▶ Pre-programmed temperature curves including temperature compensation for power and pharmaceutical industry applications.
- ▶ Approved/Certified as intrinsically safe device for use in hazardous area locations.
- ▶ FDT certified DTM (Device Type Manager).
- ▶ Auto-switching from a wide range to a very sensitive range without need for recalibration.
- ▶ Two levels of configurable passcode protection provided.
- ▶ Compatible with all Foxboro 871CC and 871CR conductivity and resistivity sensors.
- ▶ Complies with applicable NAMUR standards, and EMC directive 2004/108/EC.
- ▶ Enclosure meets IP66 and NEMA 4X ratings.
- ▶ Output hold.

(1) Usable with HART Versions 5, 6, and 7.

(2) Patent pending.

APPLICATION FLEXIBILITY

Microprocessor technology, coupled with a simple user interface, allows rapid customization of the transmitter to specific application requirements. Contacting conductivity or resistivity applications can be handled by simple configuration of the transmitter to the desired measurement. Temperature compensation, for conductivity and resistivity measurement is equally flexible.

CONDUCTIVITY, RESISTIVITY, OR CONCENTRATION MEASUREMENT

The transmitter can be configured to measure in conductivity units ($\mu\text{S}/\text{m}$, $\mu\text{S}/\text{cm}$, mS/m , mS/cm , or S/m), resistivity units ($\text{M}\Omega\cdot\text{cm}$ or $\text{K}\Omega\cdot\text{cm}$), or one of a host of chemical concentration units such as percent (%), grams per liter (g/L), parts per million (ppm), parts per thousand (ppt), and ounces per gallon (oz/gal). User programmable curves can also be used for special applications such as uncommon chemicals, proprietary processes, or non-binary solutions.

CUSTOMIZE AND EMPLOY UP TO THREE APPLICATIONS

This unique feature allows you to preconfigure the transmitter for up to three different applications. Each application may have its own display format, temperature compensation curve, chemical concentration curve (if applicable), and output configuration. Each application is assigned a number, for example, "Application 1", "Application 2", or "Application 3". If you wish to switch from one application to another, you can simply change one parameter in the configuration menu and the entire application set switches in automatically. This is a powerful feature for users who frequently change between a handful of common, or even custom, recipes.

AUTO-SWITCHING

A useful extension to the multi-application feature is an auto-switching capability between either two or three applications. User-programmable switch limits determine when the transmitter auto-switches from Application 1 to Application 2, then again from Application 2 to Application 3. Similarly, the transmitter auto-switches in descending fashion depending on the program set by the user. Because each of the applications (three maximum) is individually configured, calibration constants are stored in memory and invoked as the application is retrieved. Thus the transmitter can switch from a wide range conductivity application to a very sensitive one (e.g., Rinse, Product, and CIP) without the need to recalibrate the system for the new range and compensations. This results in tremendous time savings for operators, and eliminates common sources of error in critical applications.

CONFIGURATION OF PARAMETERS

User configurable parameters are listed below.

Refer to MI 611-260 for the menu structure and further details of each parameter.

- ▶ Cell Configuration (Cell Constant, Temperature Sensor Type)
- ▶ Measurement Configuration (Units, Display Format, and Damping)
- ▶ Temperature Configuration (°C, °F, Automatic, or Manual mode)
- ▶ Temperature Compensation (Units for Different Solutions)
- ▶ Analog Output/PV (Source Measurement, Low/Upper Value, HART SV/TV/QV)
- ▶ Measurement Display (Single, Dual, Multiple (3) Measurements)
- ▶ Number of Applications (1, 2, or 3)
- ▶ Run Applications (Auto, Application 1, 2, or 3)
- ▶ Analog Output Failsafe (Off, Fail Low, Fail High)
- ▶ HART Digital (Versions 5, 6, or 7)
- ▶ Enable/Disable Diagnostics (Enable/Disable All, ATC Short/Open, Compensation/Measurement Range, Leakage)
- ▶ Auto Hold (Off, On Present, On Manual)
- ▶ Configuration Timeout (Never, Always, Online only)
- ▶ Restore Configuration (User1, User2, Factory)
- ▶ Stability (Stability during calibration)
- ▶ Passcode Access (Administrator Code, User Code, User Change, User View)
- ▶ Transmitter Tags (Device Name, Tag Name, Location, HART Message/Tag/ Long Tag/Descriptor)

TEMPERATURE PREDICTION

For a Foxboro cell type, a proprietary mathematical algorithm is applied to accelerate the cell's response to changes in the process temperature. This reduces errors that may appear in the compensated measurements when the process temperature changes rapidly.

SAVE AND RESTORE CONFIGURATIONS

Configuring an electrochemical transmitter involves the setting of many parameters specific for the application. For example, measurement, sensor configuration, temperature compensation, output, chemical composition, damping, and cell factor are just a few of the parameters that can be configured. In some cases, you may wish to employ the transmitter for more than one application (at different times). Rather than having to change several parameters, the Model 876CR allows you to save up to two unique and complete configuration profiles, each of which has three applications. Either of these two profiles can be restored at any time to facilitate a quick and easy change of the transmitter to a pre-saved configuration. In addition to the two user profiles, the transmitter also includes a "factory default" configuration which allows you to return the transmitter to its original factory configuration at any time.

INTRINSICALLY SAFE DESIGN

The 876CR Transmitter complies with FM, CSA, ATEX, and IECEx standards for intrinsically safe apparatus in hazardous area locations. Also refer to the Electrical Safety Specifications section.

COMPATIBLE WITH 871CR AND 871CC SENSORS

For optimum performance and ease of use, the Foxboro 871CR Series Sensors (see Figure 1) are recommended. When a complete loop (analyzer plus sensor) is required, Invensys highly recommends the 871CR Sensor. However, Invensys understands that the installed base of 871CC sensors is very large, considering they were utilized on several previous models of conductivity and resistivity analyzers, including Models 870, 870IT, 872, 873, and 874. Therefore, the 876CR Transmitter was designed for

compatibility with 871CC Sensors, and is able to replace an existing installation of Model 870, 870IT, 872, 873, or 874 instruments without changing sensor inventory.

Compatibility with 871CR and 871CC sensor types is achieved through programmable configuration of cell factor and temperature sensor parameters. The analyzer accepts temperature inputs from a 2- or 3-wire 100 Ω RTD, 2- or 3-wire 1000 Ω RTD, and from a 10 k Ω and a 100 k Ω thermistor.

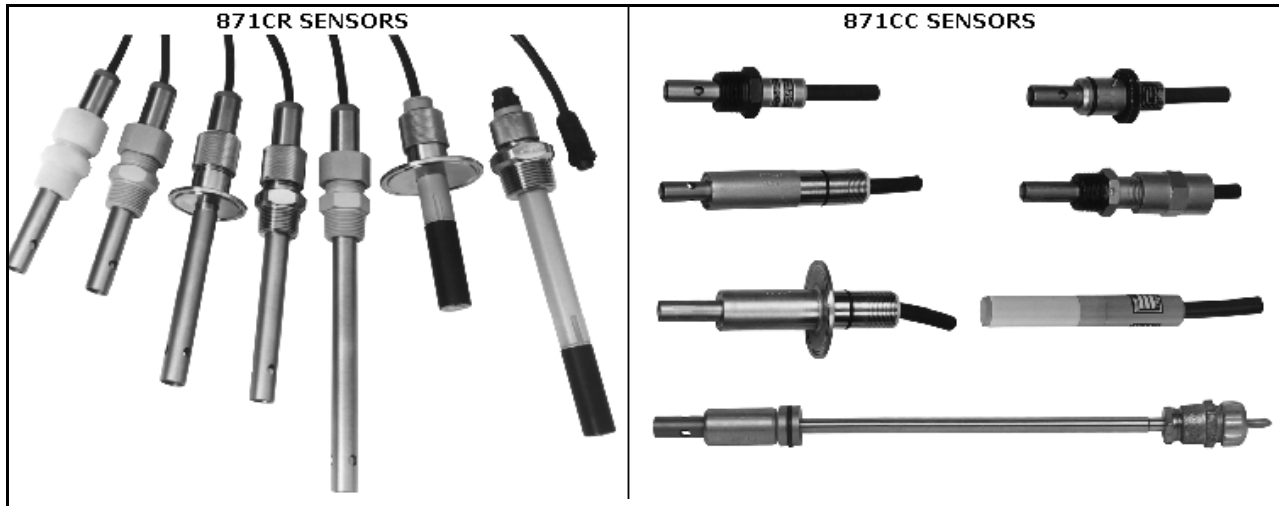

Figure 1. Foxboro 871CR and 871CC Series Sensors

LOCAL HUMAN INTERFACE

A local human interface, as shown in Figure 2, provides local display, diagnostics, and setup. The interface consists of a 128 x 64 dot matrix LCD, a 12-key alpha-numeric keypad, four directional arrows, and an ENTER key. Note that the user functions available via the local interface are also available through external interfaces.

The UP and DOWN arrows are used to scroll through menu selections, which wrap from the last to the first item. HELP messages appear at the bottom of every display screen, except for measurement displays. If there is a fault, the fault symbol on the title bar will flash. When the transmitter is in HOLD, this is indicated in the upper right of the display (see Figure 4 for location of displays). There is also a full help display accessed via the HELP function key. Help displays also appear before each calibration operation. A typical diagnostics display is shown in Figure 3, and a typical dual measurement display is shown in Figure 4.

DISPLAY SIZE AND FORMAT

The LCD viewing area is 71 mm wide x 38.9 mm high (2.80 in wide x 1.53 in high), and displays Measurements, Status, Configuration settings, and Calibration settings. You may configure the interface to display one, two, or three measurements. Font sizes can be extra large, large, medium, or small depending on what is being displayed.

For example, a single measurement display (conductivity) will have an extra large font size, while a dual measurement display (conductivity and temperature) will have a large font size.

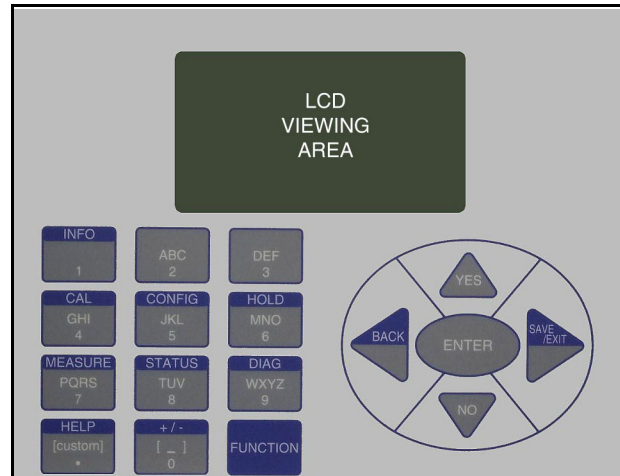

Figure 2. Local Human Interface

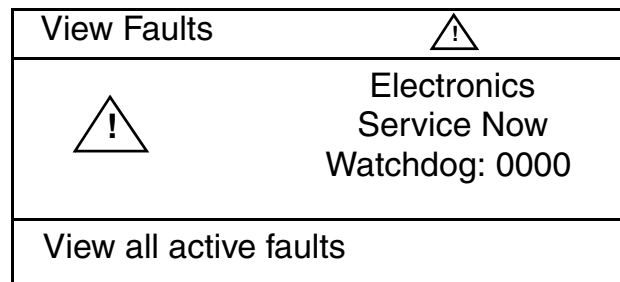

Figure 3. Typical Fault Display

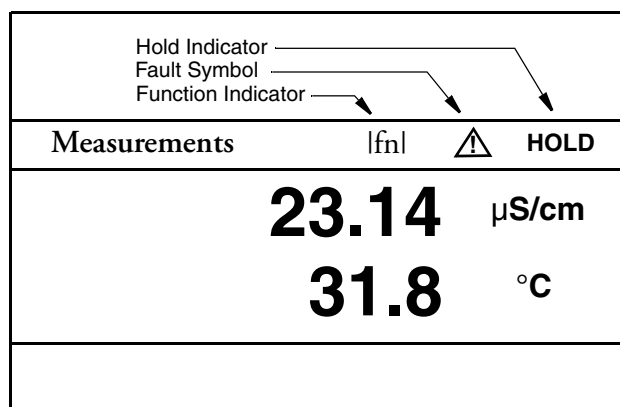

Figure 4. Typical Dual Measurement Display

HISTORY LOGS

You can view the history log and clear it. The history log can be viewed by using any of the four filters: an error selection, an operational selection, a calibration selection, and an all history selection. The history log includes all faults, power restore, entries, and exits from configuration, calibration and Hold, and faults that have been temporarily suspended.

SECURE DATA AND CALIBRATIONS

Two levels of security protect against unauthorized configuration/calibration changes, loss of data, and/or invalid measurement signals.

The first level permits access to routine maintenance functions, including calibration and output hold, but only permitted by the second level of security.

The second level permits changes to all configuration parameters by authorized personnel.

Data is stored in EEPROM, obviating the need for battery backup. Measurement loop security is enhanced by a user programmable “fail signal” parameter activated by any transmitter fault and certain serious sensor faults. This “fail signal” parameter forces the transmitter output to off-scale Fail High or Fail Low per NAMUR Standard NE 43.

HIGH SENSITIVITY, WIDE RANGE

Highly accurate measurements are provided by the combination of 876CR Transmitter and an 871CR Sensor. Refer to Table 1 on page 12 and Table 3 on page 13 for a listing of the wide variety of resistivity and conductivity ranges available.

MEASUREMENT INTEGRATION

This transmitter provides efficient integration of measurements into HART process control schemes. It operates by using a bidirectional digital signal superimposed on the 4 to 20 mA analog output.

Remote communication of digital values plus status and configuration information can be achieved via HART communication protocol.

Configurations used with this HART version are:

- ▶ The HART Communicator (users having HART Communicator for other devices can have them upgraded with Foxboro DDs to accommodate this transmitter).
- ▶ The local Human Interface (see previous section).
- ▶ A PC-based configurator (FDT).
- ▶ A Distributed Control System (DCS).

With HART, digital multidropping is permitted. This is the connection of several transmitters to a single communications line. Multiple transmitters can be connected on a single twisted pair of wires. See Figure 7.

QUICK AND INFORMATIVE STATUS

Using the status key, you can gain access to all the information necessary to assess the performance of the measurement loop. Among the parameters this “read only” key accesses are:

- ▶ Solution Temperature
- ▶ Absolute Measurement
- ▶ Compensated Measurement
- ▶ Chemical Concentration
- ▶ Measurement Status
- ▶ Date of Last Calibration

SENSOR AND TRANSMITTER DIAGNOSTICS

The diagnostic mode enables you to view active faults, view history log, suspend faults, resume suspended faults, and save two user configurations. Typical faults include:

- ▶ Measurement Overrange and Underrange
- ▶ Compensation Overrange and Underrange
- ▶ Analog Output Overrange and Underrange
- ▶ Sensor Faults
- ▶ Liquid Leakage into Sensor Body
- ▶ ATC Short and ATC Open

You can enable or disable some of the listed faults. Fault status is displayed in the main Diagnostic Menu. If there are no faults, then “No Active Faults” will be displayed. You can suspend active faults from the measurement status for one hour, and can resume faults at any time.

DURABLE FIELD-MOUNTED ENCLOSURE

The 876CR is housed in a durable aluminum alloy enclosure that is designed to withstand severe field conditions. The enclosure has the dusttight and weatherproof rating of IP66 as defined by IEC 60529, and provides the environmental and corrosion-resistant protection rating of NEMA 4X.

Its efficient DIN panel-size design allows easy mounting for panel, pipe, or surface applications. A hinged front door provides easy front access to field connections. Large spade lug terminals for sensor and communications connections facilitate quick maintenance and calibration procedures. The keypad overlay is constructed of polyester material.

The transmitter can also be provided with an optional clear plastic storm door to prevent accidental activation of the front panel controls.

OPERATING, TRANSPORTATION, AND STORAGE CONDITIONS

Influence	Reference Operating Conditions	Normal Operating Conditions	Transportation and Storage Limits
Electronic Ambient Temperature	23 ± 2°C (73 ± 4°F)	-30 to +70°C ^(a) (-22 to +158°F)	-30 and +70°C (-22 and +158°F)
Display Ambient Temperature	23 ± 2°C (73 ± 4°F)	-20 to +70°C ^{(b) (a)} (-4 to +158°F)	-30 and +70°C (-22 and +158°F)
Relative Humidity	50 ± 10%	5 to 90% ^(c) Noncondensing	5 and 90% Noncondensing
Supply Voltage Over 4 to 20 mA 2-Wire Line	24 ± 2 V dc	12.8 to 42 V dc See Figure 5	Not Applicable
Output Load	250 Ω	0 to 1300 Ω (Figure 5)	Not Applicable
Isolation	±1 V dc	For Intrinsically Safe Applications: ±24 V dc For General Purpose (Ordinary) Locations: ±42 V dc	Not Applicable
Vibration	Negligible	For Panel Mounting: 2.5 m/s ² (0.25 “g”) from 5 to 200 Hz For Pipe or Surface Mounting: 10 m/s ² (1 “g”) from 5 to 200 Hz	Protected by Shipping Container

(a) Refer to the Electrical Safety Specifications section for a restriction in ambient temperature with certain electrical certifications.

(b) The LCD Indicator may have degraded performance between -20 and -30°C (-4 and -22°F).

(c) The transmitter will operate at a low limit of 0% RH but with a possible degradation of performance.

PERFORMANCE SPECIFICATIONS

(Transmitter Specifications under Reference Operating Conditions unless otherwise specified. Refer to Sensor Literature for Sensor Specifications.)

Accuracy – Digital Measurement (Includes Linearity, Hysteresis, and Repeatability)

ABSOLUTE CONDUCTIVITY AND RESISTIVITY MEASUREMENT

± 0.5% of absolute reading over the input range of 40 Ω to 10 MΩ. Measurements are possible outside this range, display format permitting, but accuracy may be reduced.

Accuracy Examples:

Cell Factor (CF) (cm ⁻¹)	0.5% Accuracy Range ^(a)
0.1	0.0100 to 2500 μS/cm 0.0004 to 100.0 MΩ•cm
1.0	0.0001 to 25.00 mS/cm 0.0400 to 9999 kΩ•cm
10	0.0010 to 250.0 mS/cm 0.0040 to 999.9 kΩ•cm

(a) 1.0% with 28°C (50.4°F) transmitter temperature change.

Accuracy - Analog Output

Analog output accuracy is equal to the digital measurement accuracy plus an additional 0.04% of full span (4 to 20 mA).

Accuracy – Solution Temperature (at 25°C/77°F Reference)

WITH 3-WIRE 1000 Ω PLATINUM RTD

±0.03°C (±0.05°F)

WITH 3-WIRE 100 Ω PLATINUM RTD

±0.1°C (±0.18°F)

WITH 2-WIRE 1000 Ω PLATINUM RTD

±0.3°C (±0.5°F)

WITH 2-WIRE 100 Ω PLATINUM RTD

±0.5°C (±0.9°F)

WITH 10 kΩ THERMISTOR

±0.1°C (±0.18°F) between 0 and 70°C (32 and 158°F)

WITH 100 kΩ THERMISTOR

±0.1°C (±0.18°F) between 0 and 70°C (32 and 158°F)

PERFORMANCE SPECIFICATIONS (CONT.)

Ambient Temperature Effect on Digital Measurement Accuracy

The effect listed below is for a 28°C (50.4°F) change in transmitter temperature within Normal Operating Condition limits.

ABSOLUTE CONDUCTIVITY AND RESISTIVITY MEASUREMENT

± 0.5% of absolute reading over the input range of 40 Ω to 10 MΩ.

Ambient Temperature Effect on Analog Output Accuracy

Digital Measurement effect plus an additional ±0.01% of span per °C.

Ambient Temperature Effect on Solution Temperature Accuracy

The effect listed below is for a 28°C (50.4°F) change in transmitter temperature within Normal Operating Condition limits.

WITH 3-WIRE 1000 Ω PLATINUM RTD
±0.03°C (±0.05°F)

WITH 3-WIRE 100 Ω PLATINUM RTD
±0.1°C (±0.18°F)

WITH 2-WIRE 1000 Ω PLATINUM RTD
±0.3°C (±0.5°F)

WITH 2-WIRE 100 Ω PLATINUM RTD
±0.5°C (±0.9°F)

WITH 10kΩ THERMISTOR
±0.1°C (±0.18°F); between 0 and 70°C (32 and 158°F)

WITH 100 kΩ THERMISTOR
±0.1°C (±0.18°F); between 0 and 70°C (32 and 158°F)

PERFORMANCE SPECIFICATIONS (CONT.)

Relative Humidity Effect (5 to 95% RH)

No additional effect on performance specifications for noncondensing environments.

Supply Voltage and Load Effect

DIGITAL

Less than 0.005% of full scale per volt

ANALOG

Less than 0.005% of analog scale per volt, in addition to digital effect.

Mounting Position Effect

Transmitter meets reference accuracy specifications for all mounting positions.

Output Noise

Included in reference accuracy specifications.

Response Time

Response time is defined as a 90% response to a stepped input change.

CONDUCTIVITY OR RESISTIVITY MEASUREMENT

Less than 3 s with no damping.

TEMPERATURE (RTD) MEASUREMENT

Less than 5 s (without temperature prediction enabled).

Measurement Stability

Stability listed below is after six months (noncumulative):

ABSOLUTE CONDUCTIVITY MEASUREMENT

Twice the absolute conductivity measurement accuracy value.

ABSOLUTE RESISTIVITY MEASUREMENT

Twice the resistivity measurement accuracy value.

Temperature Measurement Stability

$\pm 0.05^{\circ}\text{C}$ after six months (noncumulative).

Common Mode Rejection

120 dB, dc; or 50/60 Hz, ac; between loop and sensor (42 volts peak).

Minimum Output Span

0.4% of instrument range.

Maximum Output Span

100% of selected display format.

NAMUR Compliance

The transmitter complies with the following NAMUR Standards:

- ▶ NAMUR NE 21 for interference immunity requirements
- ▶ NAMUR NE 43 for analog overrange and underrange annunciations

Electromagnetic Compatibility (EMC)

The transmitter, when installed in accordance with MI 611-260, meets EMC directive 2004/108/EC by conforming to the following EN and IEC Standards:

- ▶ Radiated RF Immunity per IEC 61000-4-3
- ▶ Radiated RF Emissions per EN 55011:199
- ▶ Electrostatic Discharge per IEC 1000-4-2
- ▶ Switching and Indirect Lightning Transient (Surge) per IEC 1000-4-5
- ▶ High Frequency Transient per IEC 1000-4-4
- ▶ Conducted RF Immunity per IEC 61000-4-6
- ▶ Power Magnetic Field Effects per IEC 1000-4-8

FUNCTIONAL SPECIFICATIONS

HART Supply Voltage Requirements and External Loop Load Limitations

See Figure 5.

HART Communications

Configurable for either Analog (4 to 20 mA) or Multidrop Mode. Digital communications is provided in both modes based upon the FSK (Frequency Shift Keying) technique which alternately superimposes one of two different frequencies on the uninterrupted current carried by the two signal/power wires. The digital signal is fully scalable over the operating range of the sensor. Remote configuration is via a HART Communicator, a PC-based configurator (such as the Model PC50 or Model HHT50), or a DCS. Local configuration is via the integral Local Human Interface keypad. The HART communication rate is 1200 baud and measurement updates are 1 time/s.

Direct Connectivity to I/A Series Open Industrial System

The transmitter can be connected directly to an I/A Series® System using fieldbus modules (FBMs). A HART FBM applicable to your installation can be provided.

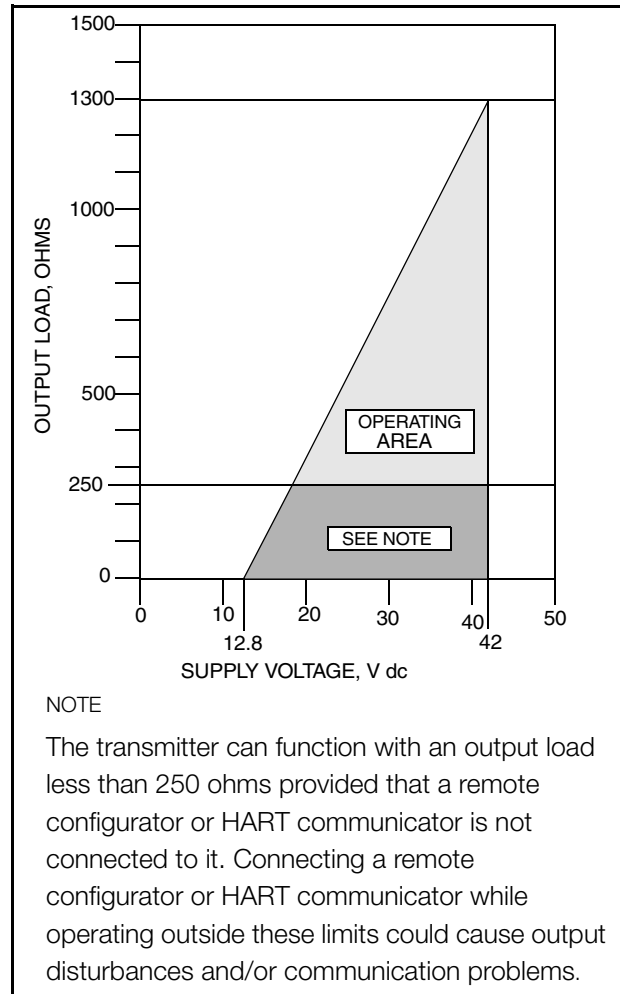

NOTE

The transmitter can function with an output load less than 250 ohms provided that a remote configurator or HART communicator is not connected to it. Connecting a remote configurator or HART communicator while operating outside these limits could cause output disturbances and/or communication problems.

Figure 5. HART 4 to 20 mA Output, Supply Voltage vs. Output Load

FUNCTIONAL SPECIFICATIONS (CONT.)

Temperature Inputs

- ▶ Factory precalibrated sensors from -30 to +200°C (-22 to +392°F)
- ▶ 100 Ω platinum RTD; 2 or 3 wires
- ▶ 1000 Ω platinum RTD; 2 or 3 wires
- ▶ 10 kΩ thermistor (thermistor is limited from -20 to 150°C)
- ▶ 100 kΩ thermistor (thermistor is limited from -20 to 150°C)

Solution Temperature Range

-30 to +200°C (-22 to +392°F)

Units of Measurements, Cell Factors, and Display Format

Refer to Table 1 and Table 3.

Table 1. Conductivity and Concentration Display Format^(a)

Cell Factor	Unit	Display Format				
		0.9999 to 9999				
0.1	μS/cm	0.9999	9.999	99.99	999.9	9999
1.0		0.9999	9.999	99.99	999.9	9999
10		0.9999	9.999	99.99	999.9	9999
0.1	μS/m	0.9999	9.999	99.99	999.9	-
1.0		-	9.999	99.99	999.9	9999
10		-	-	99.99	999.9	9999
0.1	mS/m	0.9999	9.999	99.99	999.9	-
1.0		0.9999	9.999	99.99	999.9	9999
10		0.9999	9.999	99.99	999.9	9999
0.1	mS/cm	0.9999	9.999	-	-	-
1.0		0.9999	9.999	99.99	-	-
10		0.9999	9.999	99.99	999.9	-
0.1	S/m	0.9999	-	-	-	-
1.0		0.9999	9.999	-	-	-
10		0.9999	9.999	99.99	-	-

(a) In the table, '9' represents a placeholder for a digit. The actual measurement capability is determined by the cell factor and units selected.

Table 2. Scale in Percent and mS/cm Equivalent Values

Chemical	Reference Temperature	Concentration Range	Temperature Compensated Range	Base Display Scale
NaCl	25°C	0 to 28%	0 to 252 mS/cm	999.9 mS/cm
KCl	20°C	0.5 to 16%	8 to 220 mS/cm	999.9 mS/cm
CH ₃ COOH	25°C	0 to 15%	0 to 1.8230 mS/cm	9.999 mS/cm
H ₃ PO ₄	25°C	0 to 36%	0 to 210 mS/cm	999.9 mS/cm

FUNCTIONAL SPECIFICATIONS (CONT.)

Table 3. Resistivity Display Format^(a)

Unit	Cell Factor	Display Format: 0.9999 to 9999 Only				
MΩ•cm	0.1	0.9999	9.999	99.99	-	-
	1.0	0.9999	9.999	99.99	-	-
	10	-	-	-	-	-
kΩ•cm	0.1	0.9999	9.999	99.99	999.9	9999
	1.0	0.9999	9.999	99.99	999.9	-
	10	0.9999	9.999	99.99	999.9	-

(a) In the table, '9' represents a placeholder for a digit. The actual measurement capability is determined by the cell factor and units selected.

Digital Outputs

1ST DIGITAL MEASUREMENT

Independently assignable to conductivity or resistivity (absolute or temperature compensated), temperature sensor resistance, solution temperature, chemical concentration, or cell resistance, if selected. Also, the primary measurement (PV) is automatically assigned as the analog output.

2ND, 3RD, AND 4TH DIGITAL MEASUREMENTS

Independently assignable to conductivity, resistivity, concentration, temperature sensor resistance, solution temperature, or cell resistance.

FACTORY DEFAULT SETTINGS

- PV = Conductivity or Resistivity Measurement, temperature compensated
- SV = Solution Temperature
- TV = Conductivity or Resistivity Measurement, absolute
- QV = Temperature Sensor Resistance

Analog Output

- ▶ Configurable to Concentration, Conductivity, Resistivity, or Temperature
- ▶ Linear Output within Measurement Range
- ▶ Analog Output Configurable to Fail Safe
- ▶ Analog Output Hold Function

Fail Safe Output

Fail Safe output is configurable to OFF, FAIL LOW or FAIL HIGH. The factory default is OFF.

- ▶ OFF: The analog output continues to produce the available measurement without necessarily indicating a failure.
- ▶ FAIL LOW or FAIL HIGH: User-configurable to FAIL LOW (3.6 mA) or FAIL HIGH (22 mA) upon failure, consistent with NAMUR Standard NE 43.

FUNCTIONAL SPECIFICATIONS (CONT.)

Temperature Compensation

Temperature compensation converts the absolute conductivity measured at the actual solution temperature to the conductivity that the selected chemical would have at a fixed reference temperature. See Table 4 and Table 5 for supported compensations.

Sensor Compatibility

- ▶ 871CC Series contacting conductivity and resistivity sensors.
- ▶ 871CR Series contacting conductivity and resistivity sensors.

Precalibrated Measurement Ranges

All electronic ranges are calibrated in the factory.

Measurement Damping

Measurement damping is continuously adjustable from 1 to 300 seconds.

Output Hold

Output Hold is a feature that allows sensor maintenance such as cleaning or calibration without control system upsets. Both digital and analog outputs can be configured to output hold.

- ▶ OFF: The dynamic output tracks the live sensor readings.
- ▶ On Present: The output remains frozen at the last value when output hold was invoked.
- ▶ On Manual: Output held at a preconfigured value.

Output hold can also be configured for automatic

Table 4. Supported Temperature Compensation for Conductivity Measurements

Chemical	Reference Temperature	Temperature Range	Absolute Range	Temperature Compensated Range	Concentration Range
Absolute	N/A	Instrument Range	Instrument Range	Instrument Range	N/A
NaCl	25°C	0 to 200°C	0 to 1210 mS/cm	0 to 252 mS/cm	0 to 28%
KCl	20°C	0 to 50°C	0 to 330 mS/cm	0 to 237 mS/cm	0.5 to 16%
Cation	25°C	-10 to 122°C	0 to 226 µS/cm	0 to 100 µS/cm	N/A
Linear	As Entered	Instrument Range	Instrument Range	Not Specified	N/A
H ₃ PO ₄	25°C	4.4 to 93.3°C	0 to 300 mS/cm	0 to 210 mS/cm	0 to 36%
CH ₃ COOH	25°C	0 to 110°C	0 to 2.8537 mS/cm	0 to 1.8230 mS/cm	0 to 15%
Ammonia	25°C	0 to 100°C	Instrument Range	Not Specified	N/A
Morpholine	25°C	0 to 100°C	Instrument Range	Not Specified	N/A
Ions Only	25°C	0 to 100°C	0 to 1210 mS/cm	0 to 252 mS/cm	N/A
Custom	As Entered	As Entered	Instrument Range	Not Specified	As Entered

Table 5. Supported Temperature Compensation for Resistivity Measurements

Chemical	Reference Temperature	Temperature Range	Absolute Range	Temperature Compensated Range	Concentration Range
Absolute	N/A	Instrument Range	Instrument Range	Instrument Range	N/A
Cation	25°C	-10 to 122°C	> 0.004 MΩ•cm	0.01 to 18 MΩ•cm	N/A
Linear	As Entered	Instrument Range	Instrument Range	Not Specified	N/A
H ₃ PO ₄	25°C	4.4 to 93.3°C	> 0.003 kΩ•cm	> 0.005 kΩ•cm	0 to 36%
CH ₃ COOH	25°C	0 to 110°C	> 0.35 kΩ•cm	> 0.55 kΩ•cm	0 to 15%
Ultra Pure H ₂ O	25°C	0 to 200°C	Instrument Range	0 to 18 MΩ•cm	N/A
Ammonia	25°C	0 to 100°C	Instrument Range	Not Specified	N/A
Morpholine	25°C	0 to 100°C	Instrument Range	Not Specified	N/A
Custom	As Entered	As Entered	Instrument Range	Not Specified	As Entered

FUNCTIONAL SPECIFICATIONS (CONT.)

Continuous Diagnostics (Digital and Analog)

Complete check every eight seconds for diagnostics listed in the paragraphs that follow unless otherwise noted. When diagnostics fail, the most severe failure is displayed. Additional information can then be obtained in the diagnostics menu. All diagnostic failures are reported via the digital protocol. Many will also cause an analog Fail Safe condition. See Failsafe below.

Background Sensor Diagnostics (All Fail Safe)

- ▶ Liquid Leakage into Sensor
- ▶ Measurement Range Checks
- ▶ Temperature Sensor Range Checks (short, open, off table)

NOTE

Fail Safe = this diagnostic will cause the output to go to Fail Safe if Fail Safe is configured ON.

Background Electronics Self-Diagnostics (All Fail Safe)

- ▶ Checksum, EEPROM, EPROM, and RAM Image of Database
- ▶ Code Space Checksum
- ▶ Stack Checking
- ▶ Watch-Dog Timer
- ▶ Verify Readable Processor Registers
- ▶ Analog to Digital Converter

Application Diagnostics

- ▶ Compensation Range Checks (outside selected range for temperature compensation or concentration). Causes Fail Safe, if enabled.
- ▶ Analog Output Overage and Underrange. Causes Fail Safe, if enabled.

USP645 Diagnostics

The USP645 Overage diagnostic is for users who are processing pharmaceutical water. If the diagnostic is enabled and the absolute conductivity exceeds the maximum allowed USP value for a given temperature, the transmitter indicates this diagnostic condition.

Diagnostics Status

The following indicators are available to you in status mode by pressing the DOWN ARROW key:

- ▶ Solution Temperature Display
- ▶ Absolute Display
- ▶ Measurement
- ▶ Time of Last Calibration Display
- ▶ Other Device Status Displays
- ▶ Active Cell Factor
- ▶ Cell Resistance

Valid Configuration Check

Once a user configuration session is complete, the configuration is validated as a whole. If valid, you are given the choice to accept the configuration or abort and return to the previous configuration.

If any part of the configuration is invalid, the problem is indicated, and you can choose to fix the problem or abort.

Calibration

For each user calibration type, you are provided with detailed, step by step instructions on screen.

History Log

A history log of the 100 most recent events is stored in nonvolatile memory. Events include power up, diagnostic detection, pass code entry, configuration, calibration, and output hold entry and exit.

Passcode

Two configurable user passcode levels are supported.

Write Protect Jumper

A write protect jumper provides additional security by allowing you to prevent the local indicator (configurator) and remote configurator from writing to the electronics. Write protection fulfills the security requirements for safety systems.

FUNCTIONAL SPECIFICATIONS (CONT.)

Functional Block Diagrams

Refer to Figure 6 and Figure 7.

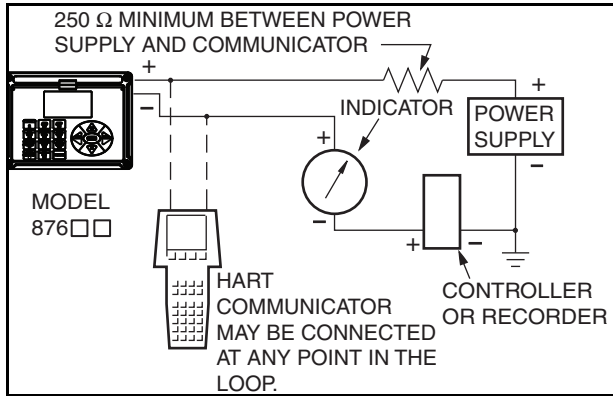

Figure 6. HART 4 to 20 mA Topology

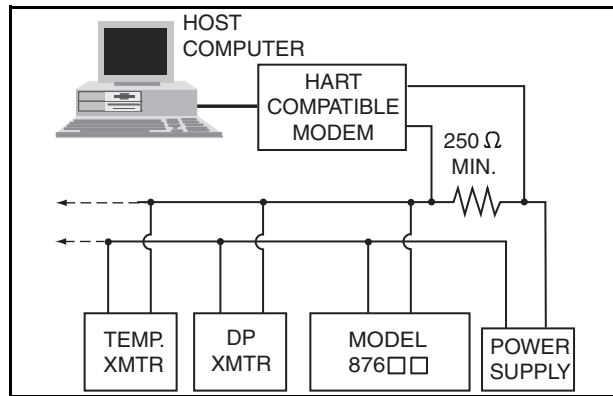

Figure 7. HART Multidrop Topology

PHYSICAL SPECIFICATIONS

Transmitter Enclosure

The transmitter enclosure comprises a housing and hinged bezel assembly. The bezel assembly attaches to the housing with captive screws, with a gasket seal between them.

HOUSING AND BEZEL MATERIAL

- ▶ Aluminum alloy (with a maximum copper content of 1%).
- ▶ Clear lexan window on bezel assembly.

GASKET MATERIAL

- ▶ Silicone Rubber, Electrically Conductive

Environmental and Corrosion Resistant Protection

The enclosure has the dusttight and weatherproof rating of IP66 as defined by IEC 60529, and provides the environmental and corrosion resistant protection rating of NEMA 4X.

Storm Door (Optional)

Made from a 0.090 inch thick, clear plastic with a polished finish.

Keypad

Durable, clear thermoplastic

Display

Liquid Crystal Display (LCD)

Transmitter Mounting

The transmitter can be panel-mounted, surface-mounted, or mounted to a DN 50 or 2-in pipe. A bracket is provided for surface or pipe mounting. See “Dimensions–Nominal” section for details.

Sensor Cable Length

The length of the cable between the sensor and transmitter can be 30 m (100 ft) maximum.

Approximate Weight

PANEL MOUNTED TRANSMITTER

3.1 kg (6.8 lb.)

SURFACE/PIPE MOUNTED TRANSMITTER

3.7 kg (8.1 lb.); includes mounting bracket.

Electrical Connections

Field wires enter through three cable entry holes at the bottom surface of the housing. Two disposable polyethylene plugs are fitted into two holes, and the third hole is fitted with a NEMA plug (for use if additional wiring is necessary). The field wires terminate at screw terminals located on a PWA (see Figure 8) located within the enclosure. These terminals are accessible by swinging down the hinged front cover. The cable entry holes are sized to accommodate standard wiring conduit or cable glands.

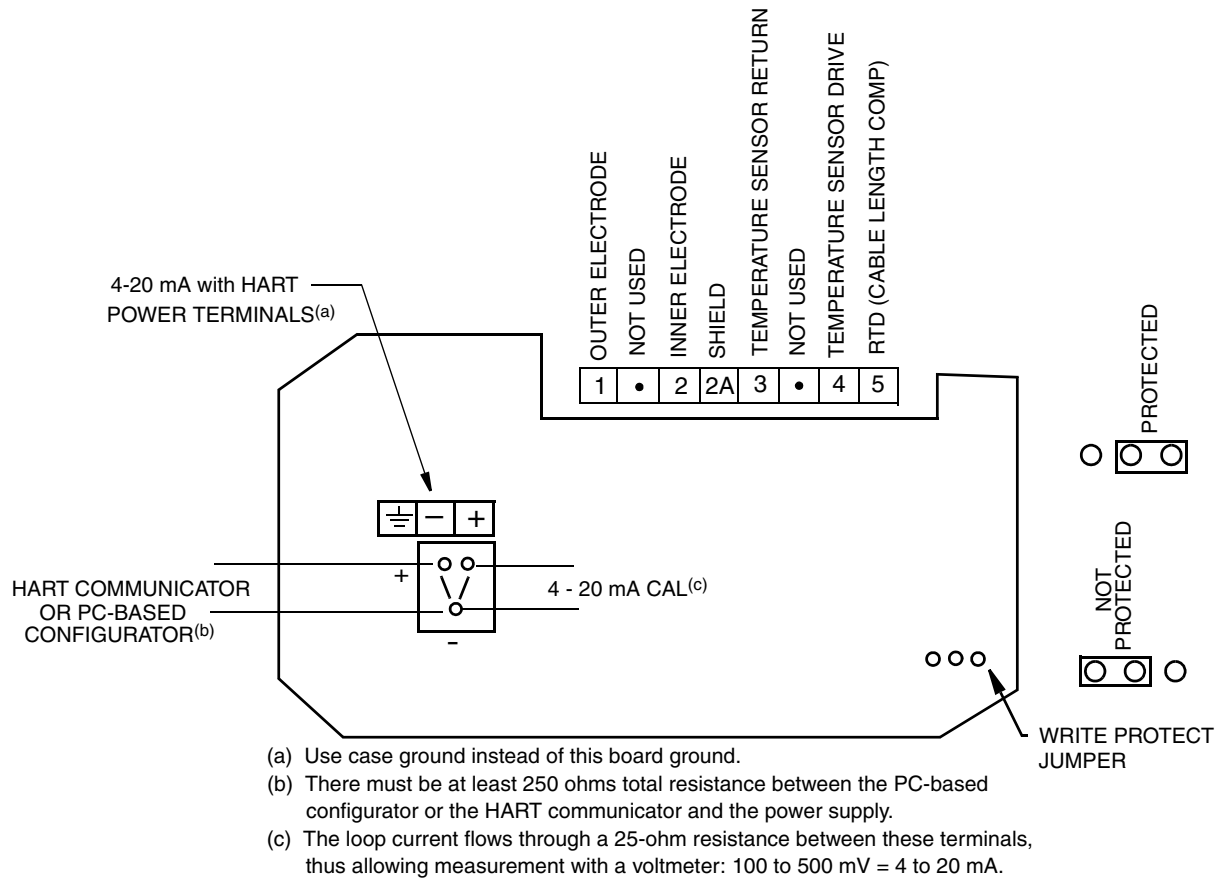

Figure 8. Electrical Connections

ELECTRICAL SAFETY SPECIFICATIONS

Testing Laboratory, Types of Protection and Area Classification	Application Conditions	Electrical Safety Design Code
ATEX II 1 G, Ex ia IIC Ga, intrinsically safe for Zone 0.	Temperature Class T4. Ta = -20 to +60°C.	AA
ATEX II 3 G, Ex ic IIC Gc, intrinsically safe for Zone 2.	Temperature Class T4. Ta = -20 to +60°C.	AN
CSA Ex ia IIC; intrinsically safe for Zone 0; and CSA intrinsically safe, Class I, II, III, Division 1, Gas Groups A, B, C, D, E, F, G.	Temperature Class T4. Ta = -20 to +60°C.	CA
CSA Ex nL IIC; energy limited for Zone 2; and CSA for Class I, II, III, Division 2, Gas Groups A, B, C, D, E, F, G.	Temperature Class T4. Ta = -20 to +60°C.	CN
FM AEx ia IIC; intrinsically safe for Zone 0; FMc Ex ia IIC; intrinsically safe for Zone 0; and FM and FMc intrinsically safe, Class I, II, III, Division 1, Gas Groups A, B, C, D, E, F, G.	Temperature Class T4. Ta = -20 to +60°C.	FA
FM AEx nC IIC; energy limited for Zone 2; FMc Ex nL; energy limited for Zone 2; and FM and FMc nonincendive, Class I, II, III, Division 2, Gas Groups A, B, C, D, E, F, G.	Temperature Class T4. Ta = -20 to +60°C.	FN
IECEX Ex ia IIC Ga; intrinsically safe for Zone 0.	Temperature Class T4. Ta = -20 to +60°C.	DA
IECEX Ex ic IIC Gc; intrinsically safe for Zone 2. IECEX Ex nL IIC Gc; energy limited for Zone 2.	Temperature Class T4. Ta = -20 to +60°C.	DN
No Certifications	N/A	ZZ

NOTE

1 Entity Parameters are as listed below:

- ▶ Intrinsically Safe Entity Parameters:
 $V_{\max} = 30 \text{ V}$, $I_{\max} = 110 \text{ mA}$, $P_{\max} = 0.8 \text{ W}$
- ▶ Nonincendive Entity Parameters:
 $V_{\max} = 42 \text{ V}$, $I_{\max} = 22 \text{ mA}$
- ▶ Sensor Output Entity Parameters:
 $V_o = 13 \text{ V dc}$, $I_o = 40 \text{ mA}$, $P_o = 350 \text{ mW}$,
 $C_o = 0.5 \mu\text{F}$, $L_o = 1.0 \text{ mH}$

2 These transmitters have been designed to meet the electrical safety specifications listed in the table above. Contact Invensys (see back page) for the status of agency approvals or certifications.

MODEL CODE

<u>Description</u>	<u>Model</u>
Intelligent Transmitter for Contacting Conductivity and Resistivity Measurement	876CR
<u>Output Signal</u>	
Intelligent; Digital HART and 4 to 20 mA	-T
<u>Enclosure Mounting</u>	
Panel Mounting	W
Surface Mounting	X
Pipe Mounting (Horizontal or Vertical Pipe)	Y
<u>Electrical Safety (Also see Electrical Safety Specifications section)</u>	
ATEX intrinsically safe; II 1 G, Ex ia IIC, Zone 0.	AA
ATEX intrinsically safe for II 3 G, Ex ic IIC, Zone 2.	AN
CSA intrinsically safe; Class I, II, III, Division 1; and Ex ia IIC, Zone 0.	CA
CSA for Class I, II, III, Division 2; and energy limited for Ex nL IIC, Zone 2.	CN
FM intrinsically safe; Class I, II, III, Division 1; and AEx ia IIC, Zone 0.	FA
FM nonincendive; Class I, II, III, Division 2; and energy limited for AEx nC IIC, Zone 2.	FN
IECEX intrinsically safe; Ex ia IIC Ga, Zone 0.	DA
IECEX intrinsically safe; Ex ic IIC Gc and Ex nL IIC Gc, Zone 2.	DN
No Certification	ZZ
<u>Optional Selections</u>	
Special per Engineering Order (a)	-1
Storm Door (b)	-7
Detailed Instruction Manual (c)	-M
Example: 876CR-TXFA-7	

(a) Provides ability to preconfigure the instrument with custom temperature compensation.

(b) Used to protect front panel controls, particularly in field mounting applications.

(c) A CD-ROM is shipped as standard with each transmitter.

DIMENSIONS-NOMINAL

$\frac{\text{mm}}{\text{in}}$

TRANSMITTER ASSEMBLY

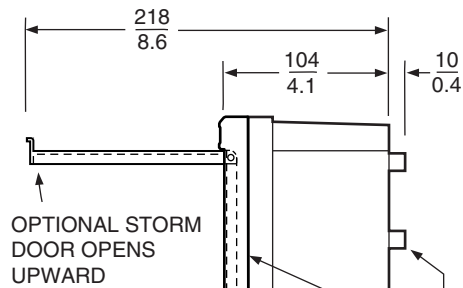
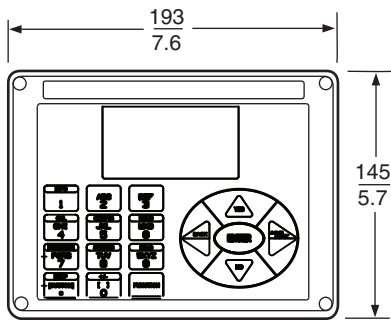

GASKET BETWEEN
CASE AND HINGED
FRONT COVER.

FOUR BOSSES ON REAR SURFACE
TAPPED 0.250-20, 6.4 mm (0.25 in)
DEEP ARE USED FOR SURFACE OR
PIPE MOUNTING OF TRANSMITTER.
CENTERS OF BOSSES ARE ON A
89 mm (3.5 in) BOLT CIRCLE.

FRONT COVER
HINGES DOWNWARD.

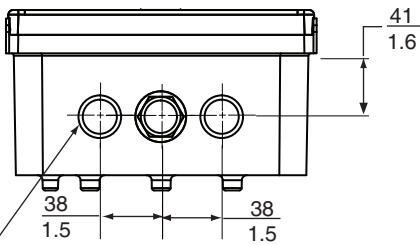

TWO 22 mm (0.87 in) DIAMETER
HOLES FOR FIELD WIRING ENTRY.
NEMA PLUG IN CENTER HOLE CAN
BE REMOVED FOR ADDITIONAL WIRING.

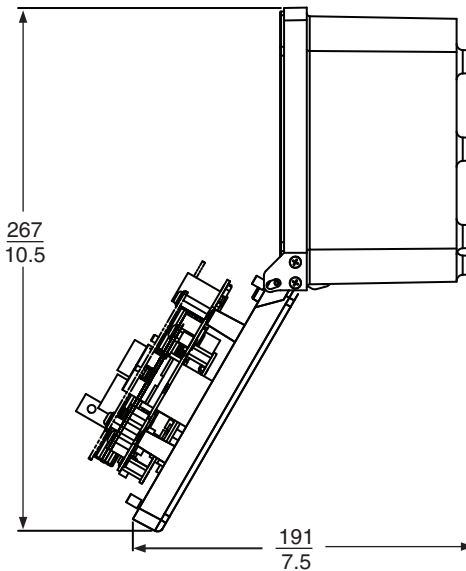

DIMENSIONS—NOMINAL (CONT.)

$\frac{\text{mm}}{\text{in}}$

TRANSMITTER MOUNTING

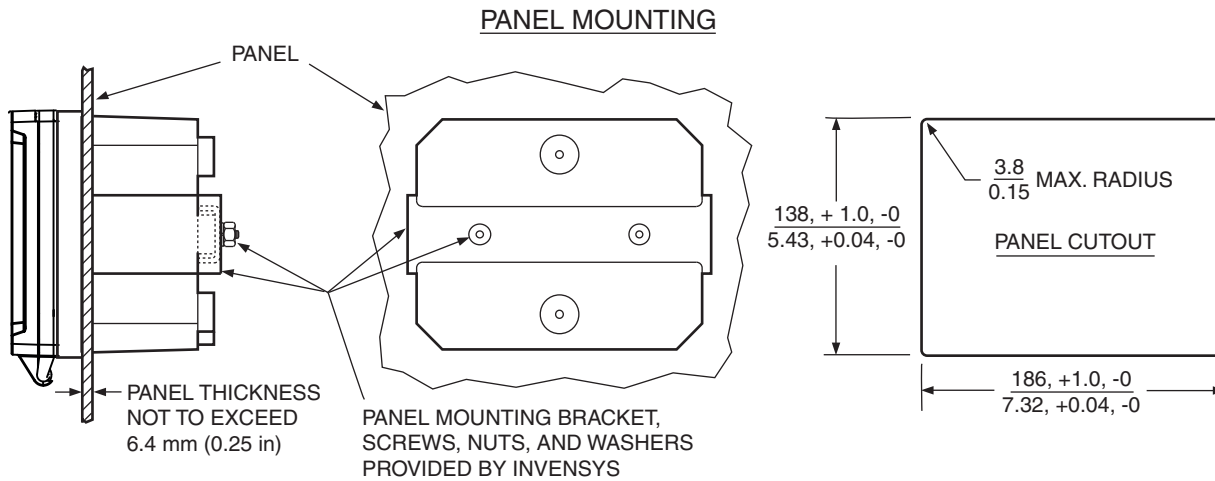

SURFACE MOUNTING

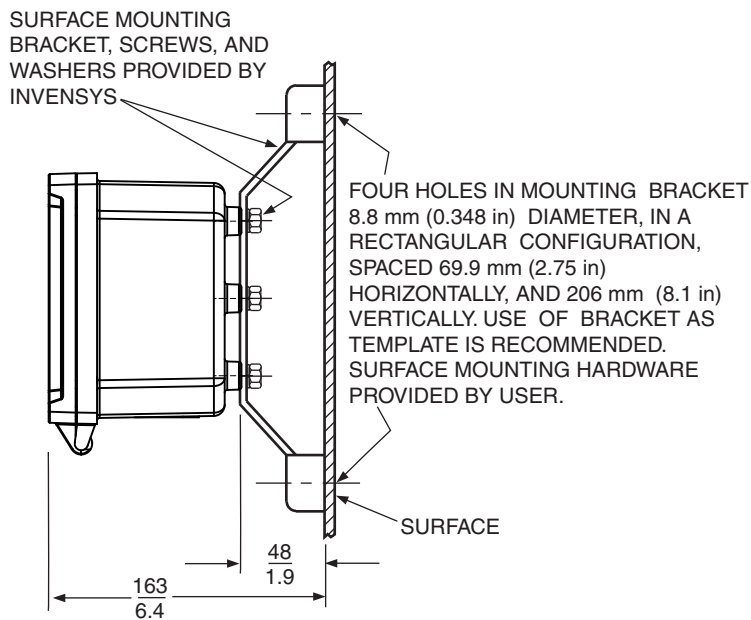

PIPE MOUNTING

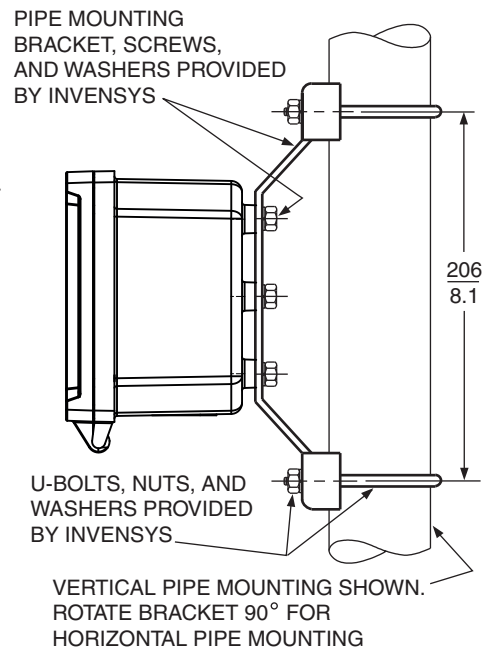

REFERENCE DOCUMENTS

Document Number	Document Description
PSS 2A-1Z3 G	Model PC50 Field Device Tool for Use with Intelligent Field Devices
PSS 2A-1Z3 L	Model HHT Configurator for Use with Intelligent Field Devices
PSS 6-3C2 A	871CC Contacting Conductivity and Resistivity Sensors and Accessories
PSS 6-3C2 B	871CR Contacting Conductivity and Resistivity Sensors and Accessories
MI 611-260	876CR Contacting Conductivity and Resistivity Transmitter
MI 611-151	871CC Contacting Conductivity and Resistivity Sensors
MI 611-221	871CR Contacting Conductivity and Resistivity Sensors
MI 611-206	Intrinsic Safety Connector Diagrams - FM, CSA, and IECEx
MI 611-208	Electrochemical Products Product Safety Information - ATEX
MI 020-520	Model PC50 Intelligent Field Device Tool with Advanced DTM Library - Operation using HART Communication Protocol

ORDERING INSTRUCTIONS

1. Model Number.
2. Sensor Cell Factor (0.1, 1.0, or 10 cm⁻¹).
3. Measurement Display Format (example 9.999 µS/cm).
4. Temperature Compensation Type.
5. Analog Output Range.
6. Temperature Compensation Input;
2-wire platinum RTD; 100 Ω
2-wire platinum RTD; 1000 Ω
3-wire platinum RTD; 100 Ω
3-wire platinum RTD; 1000 Ω
10 kΩ thermistor
100 kΩ thermistor
7. User Tag and Application.

OTHER M&I PRODUCTS

Invensys provides a broad range of Foxboro measurement and instrument products, including solutions for pressure, flow, analytical, positioners, temperature, controlling and recording. For a listing of these offerings, visit the Invensys Operations Management web site at:

www.iom.invensys.com

Invensys Operations Management
5601 Granite Parkway Suite 1000
Plano, TX 75024
United States of America
<http://iom.invensys.com>

Global Customer Support
Inside U.S.: 1-866-746-6477
Outside U.S.: 1-508-549-2424 or contact
your local Invensys representative.
Website: <http://support.ips.invensys.com>

Invensys, Foxboro, and I/A Series are trademarks of Invensys plc, its subsidiaries, and affiliates. All other brand names may be trademarks of their respective owners.

Copyright 2011 Invensys Systems, Inc.
All rights reserved

MB 010, 012