

SRD991 Intelligent Positioner with HART, FoxCom, PROFIBUS-PA, FOUNDATION Fieldbus H1 or Without Communication



The intelligent positioner SRD991 is designed to operate pneumatic valve actuators and can be operated from control systems (e.g. the Foxboro I/A Series System), controllers or PC-based configuration- and operation tools such as the DTMs VALcare™ or Valve Monitor. The positioner is available with different communication protocols. The multi-lingual full text graphical-LCD (optional with infrared interface), in conjunction with the 3 push buttons, allows a comfortable and easy local configuration and operation. For installations in contact with explosive atmospheres, certificates are available.

MAIN FEATURES

Intelligent

- Auto-start with self-calibration
- Self diagnostics, status- and diagnostic messages
- Easy local operation with three key pads
- Multi-Lingual full text graphical LCD, or LEDs
- VALcare™ or Valve Monitor DTM for valve diagnostics and predictive maintenance

with communication

- HART, FOUNDATION Fieldbus H1, PROFIBUS-PA, FoxCom
- Configuration by means of local keys, hand-held terminal (HART), PC or I/A Series system or with an infrared interface by means of IrCom

without communication

- Input signal 4 to 20 mA

- Stroke 8 to 260 mm (0.3 to 10.2 in)
- Angle range up to 95 ° (up to 300 ° on request)
- Supply air pressure up to 6 bar (90 psig), with spool valve up to 7 bar (105 psig)
- Single or double-acting
- Mounting on linear actuators according to NAMUR – IEC 534, Part 6 – VDI/VDE 3847
- Mounting on rotary actuators acc. to VDI/VDE 3845
- Protection class IP 65 (IP 66 on request), NEMA 4X
- Approved for SIL applications
- Explosion protection: Intrinsic Safety according to ATEX and FM/CSA

Contents Page

- Special Versions of SRD991 4
- Common technical data for all basic devices** 5
- Operation, Diagnostics, Service plug, IrCom 6
- Electrical classification 9
- Extended technical data for basic devices:**
- with communication HART 10
- with communication FoxCom 10
- with communication PROFIBUS or FOUNDATION F. 11
- Basic device without communication (4-20 mA) . . 12
- Additional equipment for basic devices** 13
(built into the basic device)
- Pressure sensors (not "w/o communication" version) 13
- One Option board with additional inputs / outputs:
- 2 Binary inputs or 14
- 2 Binary outputs or 15
- Position feedback and Alarm or 16
- Additional Inputs / Outputs Potentiometer Input . . 17
(for remote mounting main unit)
- Additional built-in
- Limit signal switch. 18

- FUNCTIONAL DESIGNATIONS** 20
- MODEL CODES SRD991** 21
- ACCESSORIES** for mounting to the positioner:
- Booster • Manifolds • Gauge manifolds 23
- ATTACHMENT** to actuators 26
- DIMENSIONS** 30

Electronics Version:

HART, FoxCom (Digital), PROFIBUS PA, FOUNDATION Fieldbus H1
or "without communication"

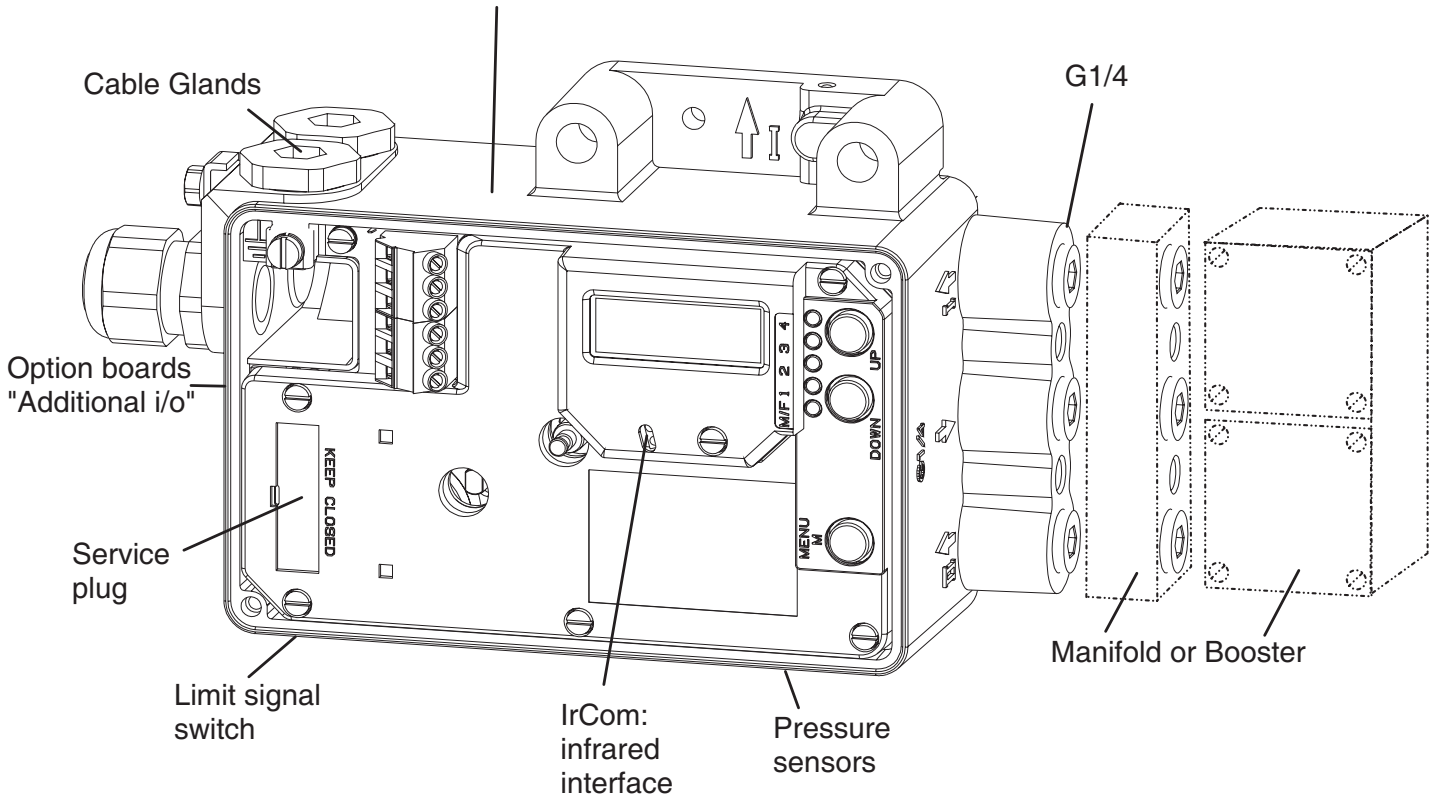

OVERVIEW

The SRD991 consists of a **basic device** with a digital controller that supports different **communication protocols** (or also simply 4-20 mA input). Into this basic device, **additional equipment** can be built such as plug-in cards for electrical input/output signals, position feedback and pressure sensors.

The pneumatic part is available in different versions (**single/double acting** or **spool valve**). For very large actuators, **boosters** with increased air capacity can be flanged on. Also, different **manifolds** for connection of gauges can be flanged on. For the pneumatic screw connections we offer different threads in the housing and adapters.

The device can be configured locally by means of push buttons and **LCD** / LED, or with PC + EDC82 Modem connected to the service plug of the SRD991. By means of communication the device can be configured remotely or with **IrCom** + PC (Infrared Interface at approx. 0.5 m).

A large variety of attachment kits for all common valves and actuators are available. The list is updated continuously and can be found on the Internet under http://www.foxboro-eckardt.com/products/positioners_en.html

For high temperature or high vibration application, we recommend to mount the SRD991 remotely and not directly on the valve. For this, use the potentiometer unit (like the SRI990 - TXQxxxxx - H).

To ensure the high performance of the positioner, we offer Advanced Diagnostics and Premium Diagnostics utilities:

	Premium Diagnostics	Advanced Diagnostics
Autostart	Yes	Yes
Custom Characterization	Yes	Yes
Autodiagnostic	Yes	Yes
Alarm Management	Yes	Yes
Alarm Output for Switching (with Optionboard)	Yes	Yes
Status List acc. NE107	Yes	Yes
Position History	Yes	Yes
Response History	Yes	Yes
On Line Friction	Yes	
Stepping Signature	Yes	
Ramping Signature	Yes	
Sensitivity Signature	Yes	
Valve Signature	Yes	
PST	Yes	
PST Predictive Maintenance	Yes	

Additional equipment, built into the basic device:

Option Board "2 Binary Inputs" <u>or</u>	2 external switches (supplied by SRD) release a control function in the SRD, e.g. "close valve" (configurable)
Option Board "2 Binary Outputs" <u>or</u>	2 binary outputs (to be supplied externally) become active during valve limit in excess of the measured valve position
Option Board "2 Binary Inputs/Outputs" <u>or</u>	2 Channels, each configurable as an Input or Output (to be supplied externally)
Option Board "Position Feedback" <u>or</u>	1 output 4-20 mA (to be supplied externally) gives stroke / angle of rotation 1 alarm output becomes active with a configurable event
Potentiometer-Entry	For connection of the external Potentiometer Unit
Limit switch	Supplies NAMUR signals when exceeding or falling below of two limit values inductive, (independent of the controller) in normal or safety version, or Micro switches
Pressure sensors	2 sensors measure the pressure of supply air and output y1; the values are passed on via communication
LCD <u>or</u>	Full text graphic LCD in 3 languages
LCD and IrCom	Full text graphic LCD in 3 languages and infrared interface

Accessories like Manifolds and Boosters see page 24

Special Versions of SRD991:

SRD991 Stainless Steel Housing

To be order with model code SRD991-Cxxxxxx-SxxxZ

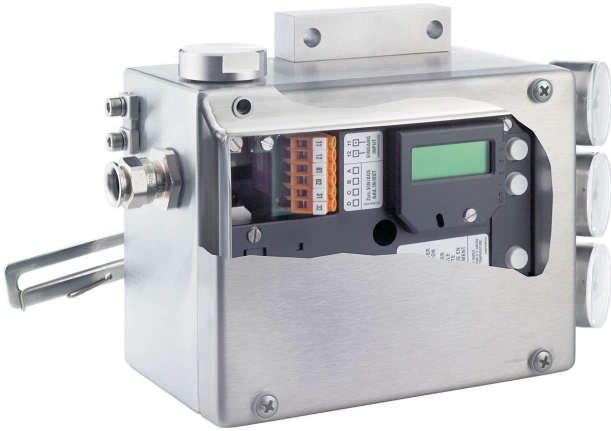

Please consult TI EVE0105 INOX

SRD991 for very Low Temperature

Special version with Heating system for temperature down to -60°C

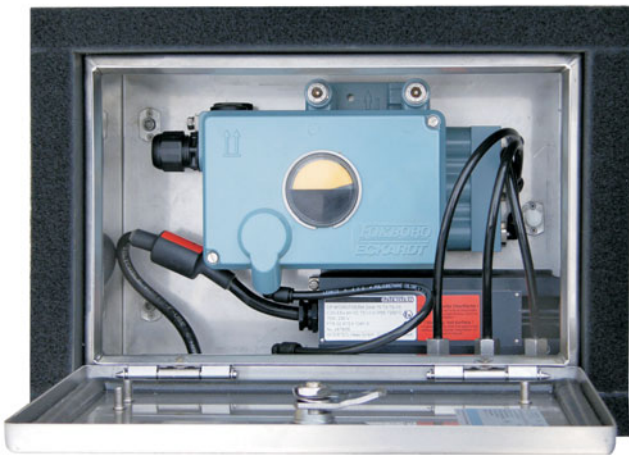

Please consult TI EVE0105 VLT

SRD991 designated for PST (Partial Stroke Test for Emergency Shut Down)

Final control elements in Emergency Shutdown (ESD) applications such as ON-OFF-, Blow Down and Venting -Valves remain in one position over a long time without any mechanical movement. These valves can show a tendency to get stuck and as a result might not operate upon demand. This can have a severe impact on the functionality of a Safety System and could result in an adverse condition to the operating personnel, plant equipment and the environment. The Partial Stroke Test (PST) offers operators a tool to identify the troubleshooting function of ESD valves. The test can be easily executed via the FDT-DTM based configuration diagnostic tool VALcare™/Valve Monitor.

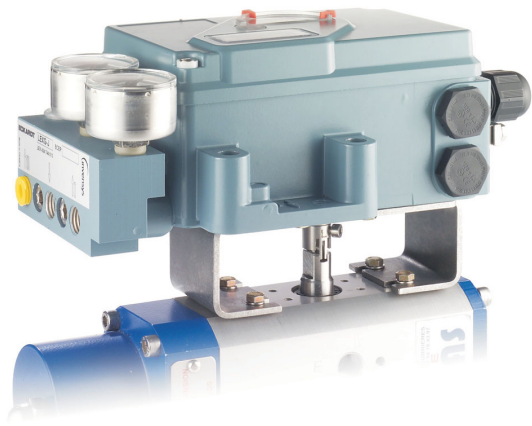

Please consult TI EVE0105 PST

SRD991 for actuator with rotation up to 300°

This special version of the SRD991 is designed to be mounted by means of standard attachment kit (like the EBZG-R) onto rotary actuator with rotation up to 300°. This special version is made of a standard SRD991 with new gears.

To be ordered under special version ECEP EP0256

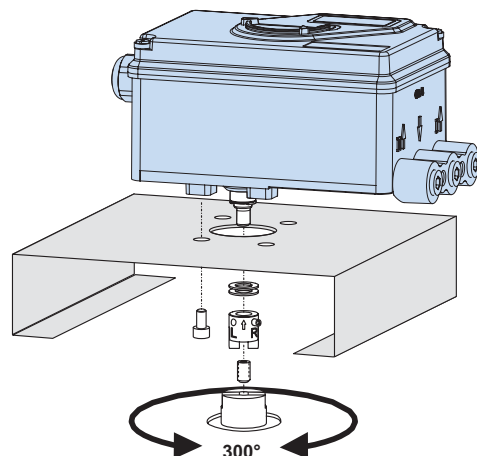

Please consult TI EVE0105 LR

FUNCTIONAL SPECIFICATIONS (common data for all versions)

Travel range

Stroke range 8 ... 260 mm (0.3 ... 10.2 in)
 with standard feedback levers; special levers on request
 Rotation angle range up to 95°
 (without mechanical stop)
 and up to 300° with a special
 construction on request
 (ECEP EPO256)

Supply

Supply air pressure 1.4 ... 6 bar (20 ... 90 psig)
 with spool valve ³⁾ 1.4 ... 7 bar (20 ... 105 psig)
 Output to actuator 0 to ~100 % of supply air
 pressure (up to 5.5 bar at
 6 bar supply air pressure)
 Air supply according to ISO 8573-1
 - Solid particle size and density class 2
 - Oil rate class 3
 - Pressure dew point 10 K under ambient temperature
 For air supply, we recommend the FOXBORO ECKARDT
 FRS923 filter regulator.

Air consumption (steady state) I_n/h (scfh)

Supply air pressure bar (psig)	1.4 (20)	3 (45)	6 (90)
single acting	100 (3.5)	110 (3.9)	150 (5.3)
double acting	260 (9.1)	290 (10.2)	400 (14.1)
Spool Valve	360 (9.1)	400 (14.2)	550 (19.4)

Response characteristic ^{1) 2)}

Sensitivity < 0.1 % of travel span
 Non-linearity (terminal based adjustment) < 0.4 % of travel span
 Hysteresis < 0.3 % of travel span
 Supply air dependence. < 0.1 % / 1 bar (15 psi)
 Temperature effect. < 0.3 % / 10 K
 Mechanical vibration
 10 to 60 Hz up to 0.14 mm,
 60 to 500 Hz up to 2 g < 0.25 % of travel span

Air output I_n/h (scfh)

at max. deviation, single and double acting:

Supply air pressure bar (psig)	1.4 (20)	3 (45)	6 (90)
without booster ⁴⁾	2 700 (95)	5 000 (177)	7 500 (265)
with Spool Valve ³⁾	6 000 (211)	12 000 (423)	18 000 (636)
with booster code F, G			21 000 (742)
with booster code H			42 000 (1 484)

Note: The use of boosters in connection with Spool valve is not recommended.

1) Data measured according to VDI/VDE 2177
 2) With stroke 30 mm and lever length 90 mm
 3) Spool valve is the type of amplifier used in device SRD991-Cxxxxx-S
 4) Standard diaphragm amplifier

FUNCTIONAL SPECIFICATIONS (common data for all versions)

Features

Automatic start-up (Autostart functionality)

Automatic determination of the mechanical end positions of the valve (initial value and final value), IP motor parameters, direction of action of the spring and control parameter.

The control parameters are optimized dynamically during this routine.

This procedure makes a perfect adjustment and optimization to the actuator possible without additional manual settings! Several autostart modes are available (details see on next page).

Options

- Built-in independent inductive limit switches
- Pressure sensors for monitoring of air supply and output pressure I (y1)
- Additional inputs / outputs:
 - Position feedback 4-20 mA + binary alarm output, to be supplied external
 - 2 binary outputs (position alarms)
 - 2 binary inputs, to be supplied external
 - 2 contact inputs, internal supplied
 - 2 binary in-/outputs, to be supplied external

Operation and Configuration

The local LCD enable a fast and easy configuration as well as univocal diagnostic.

Local with local key pads

Display. Multi-lingual Graphic LCD and five LEDs

The positioner in the version with LCD contains three different menu languages.

Standard menu languages:

- English - German

Freely selectable third language:

- French - Portuguese - Spanish
- Italian - Swedish - ...

(further menu languages on request)

The third menu language has to be selected and specified with the order, otherwise standard: French.

The third, freely selectable menu language can be modified to another language by means of the VALcare™ DTM .

The additional languages can be downloaded from our homepage. ²⁾

Diagnostics

– in the field:

- Status and Diagnostic messages via LCD
- via VALcare™ or Valve Monitor DTM ⁴⁾:
 - Service Management for planning and scheduling of service intervals
 - Histograms for displaying the position- and response-history over time
 - Partial Stroke Test for the functional inspection of safety related actuators
 - Hours in operation, cycle counter and travel sum of the actuator are determined
 - Surveillance of loop current
 - shows condition of device:
 - Potentiometer
 - IP Motor
 - exceeding range of actuator (possible indication for wear of plug or seat)
 - remaining control deviation (possible indication for jammed actuator, blocked valve stem or plug, insufficient air capacity /supply air pressure /positioning pressure)
 - if equipped with pressure sensors (optional):
 - Monitoring of the stem friction
 - Histograms for displaying the friction-history over time
 - surveillance of air supply and output pressure, each with display of physical value
- Additional diagnostical possibilities in control operation by means of external sensors (optional).
See also the VALcare™ Documentation.

Service plug and IrCom

All basic devices are equipped with a service plug **A** at the front side. There via RS232 interface a PC with VALcare™ (DTM) can be connected via modem EDC82 (galv. separated, not Ex).

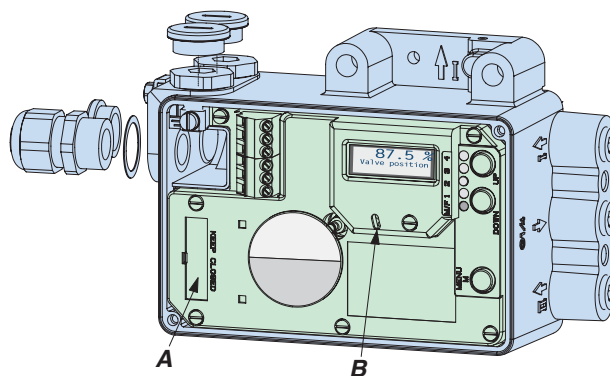

If the SRD is equipped with option "IrCom" **B**, communication can take place contactless via infrared with the positioner (even with a closed cover!). A modem "IR Interface" (not Ex) connected via RS232 interface to a PC with VALcare™ (DTM) makes communication possible up a range of approx. 0.5 m.

(If the notebook has an IrDa interface, this cannot be used despite being similar technology as IrDa instruction set has no communication commands for positioners.)

2) With the versions "Intelligent without communication" this is only possible with modem EDC82

3) By means of "Additional inputs / outputs"

4) For the SRD991 without communication the use of the service plug is necessary to have access at the diagnostic with DTM.

Manual local and remote settings:

Actuator mode	linear or rotary actuator
Linear valve	left or right mounted
Rotary actuator	opening clockwise or counter-clockwise
Characteristic of setpoint	linear, equal percentage, invers- equal percentage or custom (22 points)
Valve function	opens or closes with increasing setpoint
Split range	free upper and lower values
Travel limits	free upper and lower values
Cutoffs	free upper and lower values
Stroke range	configurable
Temperature unit	configurable (°C or °F)
Autostart	- Endpoints - Standard Autostart - Enhanced Autostart ¹⁾ - Smooth response ¹⁾ - Fast response ¹⁾
Control parameters	Determined during Autostart.
Working range	freely adjustable (for indication on LCD)
Manual adjustment of	P-gain, I-time, T63-time and dead band
Manual operation	Manual input of setpoint to drive the valve in steps of 12.5 % or 1 % ¹⁾
Pneumatic test	Function to test the pneumatic output
Workshop	input and angle calibration
LCD language	dependent on version
LCD orientation	dependent on version
PROFIBUS-PA	Bus address
FOUNDATION Fieldbus	Simulation Switch from Link Master to Basic Field Device

Software supported configurations:

- by means of Hand Held Terminal (HART)
- PC by means of VALcare™ Software
- PC among others by means of PC20/ PC50 /IFDC
- I/A Series System and other DCSs
- Depending on the version, configurations can be achieved by a non-contact, protocol-independent infrared interface by means of IRCOM.

Failure handling

Safety position at	
- Air supply failure	pressure y1 = zero
- Electric power failure	pressure y1 = zero
- Failure of electronics	pressure y1 = zero
- Failure of communication is recognized by configurable watch dog with response delay of 0.1 s to 24 h	
Behavior	configurable as
	- pressure y1 = zero or
	- stop at last value or
	- a configured value
Diagnostic report	via communication and local LCD
- Historical status	is set if alarm was activated at any time (also just short alarms)
Reset	by acknowledging

1) from HW-Rev. 3.4 / Firmware Rev. 16

PHYSICAL SPECIFICATIONS (common data for all versions)

Mounting

Attachment to stroke actuators

- direct, FlowPak/FlowTop . . . with attachment kit EBZG –E

- for casting yoke

acc. to IEC 534-6 (NAMUR) . . . with attachment kit EBZG –H
or –H1

- for pillar yoke

acc. to IEC 534-6 (NAMUR) . . . with attachment kit EBZG –K
or –K1

Stroke range

with standard feedback lever (EBZG-A) 8 ... 70 mm

with extended feedback lever (EBZG-B) 60 .. 120 mm

with extended feedback lever (EBZG-A1) 110 .. 260 mm

Attachment to rotary actuators

acc. to VDI/VDE 3845

with attachment kit EBZG -R

- Further attachment kits see ModelCodes page 25

- Mounting orientation see attachment dimensions starting
from page 26

Materials

Housing and covers Aluminum (Alloy No. 230)
finished with DD-varnish

All moving parts of

feedback system 1.4306 / 1.4571 / 1.4104

Attachment kits V4A or Aluminum, finished
with DD varnish

(depending upon version) . . . (Alloy No. 230)

Mounting bracket Aluminum (Alloy No. 230)

Pneumatic diaphragms PVMQ (Silicone elastomer,
suitable for use in the paint
industry)

Weight

Single acting approx. 1.7 kg (3.7 lbs)

Double acting. approx. 2.0 kg (4.4 lbs)

Pneumatic connection

NAMUR mounting G 1/4 for pipe diameter 6 to
12 mm (0.24 to 0.47 in) for air
supply and outputs y1, y2 to
the actuator;

1/4-18NPT with additional
connection manifold

Direct mounting Instead of the output y1, an
air connection on the back
with O-ring will be used
(closed at NAMUR mounting).

Electrical Connection

Line entry 1 or 2 cable glands 1/2-14 NPT
or M20 x1.5
(others with Adapter AD-...)

Cable diameter 6 to 12 mm (0.24 to 0.47 in)

Screw terminals 2 terminals for input,
4 terminals for additional
inputs / outputs

Wire cross section 0.3 to 2.5 mm² (AWG 22-14)

Test sockets for options and communicator
connection

Ambient conditions

Operating conditions acc. to IEC 654-1

The device can be operated at a class Dx location

Ambient temperature

Operation ¹⁾ –40 ... 80 °C (–40 ... 176 °F)

Transport and storage . . . –40 ... 80 °C (–40 ... 176 °F)

Storage conditions

acc. to IEC 60721-3-1: . . . 1K5; 1B1; 1C2; 1S3; 1M2

Indicators

LCD (visible) ²⁾ –25 ... 70 °C (–13 ... 176 °F)

LEDs –40 ... 80 °C (–40 ... 176 °F)

Relative humidity up to 100 %

Protection class ³⁾

acc. to IEC 529 IP 65; IP 66 on request

acc. to NEMA Type 4X

Electromagnetic compatibility EMC

Operating conditions industrial environment

Immunity according to

EN 61326 fulfilled

IEC 61326 fulfilled

EN 61000-6-2 fulfilled

Emission according to

EN 61326

Class A and Class B. fulfilled

EN 61000-6-4 fulfilled

EN 55011 Group 1,

Class A and Class B. fulfilled

NAMUR recommendation

EMV NE21 fulfilled

SAFETY REQUIREMENTS

CE label

Electromagnetic

compatibility ⁴⁾ 89/336/EWG, 2004/108/EG

Low-voltage regulation not applicable

Safety

According to EN 61010-1

(or IEC 1010-1) Safety class III

Overvoltage Category I

Internal fuses only with PROFIBUS or
FOUNDATION Fieldbus,
but not replaceable

External fuses Limitation of power supplies
for fire protection must be observed acc. to EN 61010-1,
appendix F (bzw. IEC 1010-1).

1) Details see Certificates of Conformity. With Option -T only –20 °C

2) Below –20 °C the LCD reacts only slowly; above +70°C the background becomes dark

3) Under service as directed

4) With PROFIBUS or FOUNDATION Fieldbus only, if shield of wiring is grounded on both sides

5) Pneumatic connection 1/4-18NPT made with a separate manifold delivered together with the device

Electrical classification ¹⁾²⁾

see Certificates of Conformity EX EVE0105 A

Type of protection “Intrinsically Safe”

Type AI 638 II 2 G EEx ia IIB/IIC,
II 2 G EEx ib IIB/IIC

Temperature classes

Version with HART communication and "without communication":

T4 with explosion protection code EA4

Version with communications HART, FOUNDATION Fieldbus, PROFIBUS-PA and FoxCom:

T4 / T6 with explosion protection code EAA

Certificate of Conformity . . . PTB 00 ATEX 2128

For use in hazardous areas in circuits certified as intrinsically safe with the following maximum values:

Input circuit:

U max = 30 V, I max = 130 mA, P max = 0.9 W

Li = negligible, Ci = 1.3 nF (5.3 nF to earth)

Ambient temperature ranges:

Temperature class T4: . . . -40 °C to + 80 °C

Temperature class T6: . . . -40 °C to + 55 °C

Explosion protection Zone 2

It is recommended to use the positioner with explosion protection "intrinsically safe" acc. to EN 50020 an EN 50014 (consider temperature class). In the EU these positioner may be operated in Zone 2 with non-intrinsically safe circuits if the operating values do not exceed the maximum reference values. The non intrinsic safe circuits has additionally fulfill the requirements of EN61010-1 (IEC 1010-1), protection grade III, overvoltage category I (transient voltage lower than 40%).

Explosion protection Zone 20

Certificate of Conformity IExU08 ATEX 1148
EX II 1D Ex iaD 20 T 100°C -40 °C < T_a < +80 °C

Electrical Data

Supply circuit in type of protection Intrinsic safety Ex ia or Ex ib

Profibus / Fieldbus		HART / Foxcom	
Ui	24 V DC	Ui	30V DC
li	380 mA	li	130 mA
Pi	5,32 W	Pi	0,9 W
Ci	1,3 nF	Ci	1,3 nF
Li	5 µH	Li	5 µH

Ci: effective inner capacity

Li: effective inner inductivity

The supply connections have an inner capacity of max. 5.3 nF opposite the ground.

The positioner type SRD991 fulfils the requirements of explosion protection for the Equipment Group II and Category 1D in type of protection Intrinsic safety for dust with a maximum surface temperature of 100 °C.

FM Type of protection

IS / I, II, III / 1 / ABCDEFG / T4 Ta = 80°C - Entity; Type 4X; DOKZ 534 396 058

NI / I / 2 / ABCD; S / II,III / FG / T4 Ta = 80°C; Type 4X;

IS / I,II,III / 1 / ABCDFG / T4 Ta = 55°C; Entity; Type 4X; DOKZ 534 396 049

NI / I / 2 / ABCD; S / II,III / 2 / FG / T4 Ta = 80°C, T6 Ta = 55°C; Type 4X

CSA Type of protection “Intrinsic Safety / Non-Incendive”

Class I. Groups A, B, C and D: Class II. Groups E, F and G: Class III:

Ex ia IIC T4/T6 IP65:

HART / 4 - 20mA / FOXCOM/Profibus/Fieldbus -abbcdefg-j

Positioner: 12-36 Vdc. 4-20 mA or 48 Vdc, Intrinsically Safe when installed as per submitor's drawings DOKZ 534 396 067 or DOKZ 534 396 076 : Temp. Code T4 at max amb. 80°C or T6 at max. amb. 55°C

Class I. Div 2. Groups A. B. C and D: Class II. Div 2. Group F and G: Class III. Div 2: IP65 End

With Electrical Classification ATEX + Zone 20 Dust, Codes ED4 and EDZ, the Travel indicator is not visible.

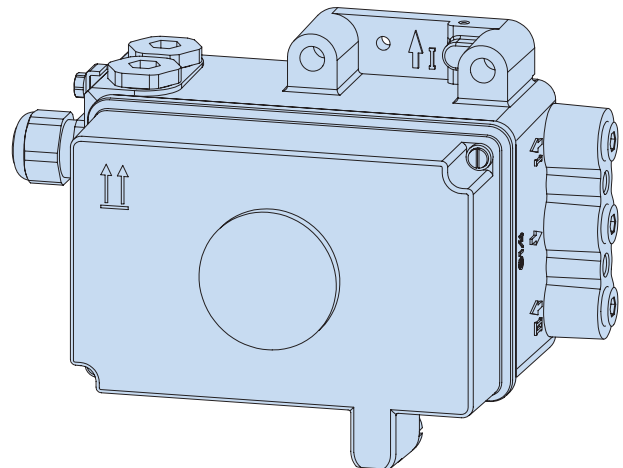

1) With appropriate order only
2) National requirements must be observed

SRD991 with HART communication SRD991-xHxxxx

- Signal Input Two wire system
- Reverse polarity protection . . standard feature
- Signal range 4 to 20 mA
- Operating range 3.6 to 21.5 mA
- Input voltage DC 12...36 V ¹⁾ (unloaded)
- Load 420 Ohms, 8.4 V at 20 mA
- Communication signal HART, 1200 Baud, FSK
(Frequency Shift Key)
modulated on 4 to 20 mA
0.5 Vpp at 1 kOhm load
- Input impedance Zi Z = 320 Ohms
for ac voltage 0.5 to 10 kHz with < 3 dB non-linearity
- Cable capacity and inductance see HART standard specifications. (e.g. C < 100 nF).
- Impedance of other devices at the input (parallel or serial) must be within HART spec.
- Applications without communication require not to exceed input capacitance parallel to the input not higher than 100 µF.
- Start-up time approx. 3 sec
- Interruption time without power down:
with LCD + LED typ. 80 ms ²⁾

Configuration

- Local / Display see page 6
- Software/Driver VALcare™ or Valve Monitor(DTM)
- Hardware HART Modem for RS232 or USB port
- Hand Held Terminal e.g. HT991, HT375, HHT50
- I/A Series System FBM215 or FBM218
(redundant) in combination with CP60 ³⁾/ FCP270
- Other control systems AMS, Siemens SIMATIC PDM (ProcessDeviceManager)
Any decentralised Control System

DTM for HART

Local Configuration

- LCD Display see page 6

Trough HART Communication

- PC20 standalone Software for PC (only trough RS232)
- VALcare™
- Valve Monitor
- Can be integrated onto any FDT Frame onto any Host suppending of FDT Frame
- H275/375
- AMS for Emerson
- PDM
- trough service port

SRD991 with FoxCom communication SRD991-xFxxxx

FoxCom is a digital communication protocol of Foxboro.

Operating mode digital (from HW-Rev.3.0)

- Input Two-wire system, digital
- Reverse polarity protection . . standard feature
- Supply voltage DC 8 to 36 V
- Supply current ~ 9 mA at 24 V
- Communication signal FoxCom digital, 4800 Baud, FSK (Frequency Shift Key), modulated on supply voltage
- Input impedance Zi ~ 500 Ohms (3 to 15 kHz)
- Start-up time approx. 2 sec
- Interruption time without power down:
- with LCD 85 ms ²⁾
- with LED 75 ms ²⁾

Cable capacitances (< 100 µF), inductances and impedance of other attached devices must conformal to FOXBORO specifications.

Configuration:

- Local with local push buttons
- Display Multi-lingual Graphic LCD and five LEDs
- Software VALcare™ -DTM
- Hardware Modem PC10
- I/A Series System FBM 43 in combination with CP40 ³⁾ (CP60 on request), and FBM 243, 246 in combination with CP60 ³⁾

1) On request we can specify higher voltage limits
2) Worst case conditions 4-20 mA, with position feedback option, i/p-output with max. current
3) Check CP for suitable ECBs

SRD991 with communication PROFIBUS-PA and FOUNDATION Fieldbus H1 SRD991-xPxxxx or SRD991-xQxxxx

PROFIBUS-PA

Data transfer according to PROFIBUS- PA
profile class B based on EN
50170 and DIN 19245 part 4

GSD file the actual file can be down-
loaded from our homepage

Configuration

Local / Display see page 6

Software VALcare™ -DTM

Hardware PC- or PCMCIA- interfaces
from Softing

I/A Series System FBM 223 in combination with
CP60 ¹⁾

Other control systems All Profibus-PA- compatible,
e.g. Siemens SIMATIC PDM
(Process Device Manager)

FOUNDATION Fieldbus H1

Data transfer FF Specification Rev. 1.4,
Link-Master (LAS)

Certified according to ITK 4.01

Function Blocks PID, AO, Transducer,
Resource

Certified according to ²⁾ ITK 4.6

Function Blocks PID, AO, 2xDI, 1xDO
Transducer, Resource

Additional functionality Flat Addressing

DD files the actual file can be down-
loaded from our homepage

Configuration

Local / Display see page 6

Software VALcare™ -DTM
or National Instruments
NI-FBUS configurator

Hardware FBUS-interfaces from
National Instruments
(AT-FBUS and
PCMCIA- FBUS)

I/A Series System FBM220 or FBM221 in
combination with CP60 ¹⁾

Other control systems All FOUNDATION Fieldbus
H1- compatible, e.g. SMAR, Fisher Rosemount Delta-V,
Honeywell, Yokogawa, ABB

For both fieldbus devices

Input signal digital

Supply voltage DC 9 to 32 V ³⁾

max. Supply voltage DC 48 V

Operating current 10.5 mA ± 0.5 mA (base current)

Current amplitude ± 8 mA

Fault current. base current + 0 mA
(base current + 4 mA by means of independent
FDE-safety circuit) according to IEC 1158-2

Operating values according to IEC 1158-2

Start-up time (init phase) approx. 2 sec

Bus connection Fieldbus interface based on
IEC 1158-2 according to FISCO-Model

Power supply Power supply is achieved
dependant on the application by means of fieldbus
power supply units or segment coupler

Electrical classification thereto

see Page 9

1) Check CP for suitable ECBs
2) From HW Rev. 3.4 / Firmware 16
3) Data of "Intrinsically Safe" version

SRD991 without communication**SRD991-xDxxxx**

Signal Input Two wire system
Reverse polarity protection . . Standard feature
Signal range 4 to 20 mA
Operating range 3.6 to 21.5 mA
Input voltage DC 8.5 to 36 V ¹⁾ (unloaded)
Load 300 Ohms, 6 V at 20 mA
With applications without communication the capacity
parallel to input may not be higher than 100 µF.
Start-up time approx. 3 sec
Interruption time without power down:
with LCD + LED typ. 80 ms ²⁾

Electrical classification thereto

see Page 9

Configuration

Local / Display see page 6
Software VALcare™ (DTM)
Hardware per modem EDC82

1) On request we can specify higher voltage limits

2) Worst case conditions 4-20 mA, with position feedback option, i/p-output with max. current

OVERVIEW ADDITIONAL EQUIPMENT
(built into any basic device)

Built-in Pressure sensors, Code Option –B

For supply air and output y1 to actuator
 Measuring range 0 to 8 bar (0 to 120 psig)
 Accuracy 2 %
 Temperature influence 0.5 % / 10k (–40 to 80°C)

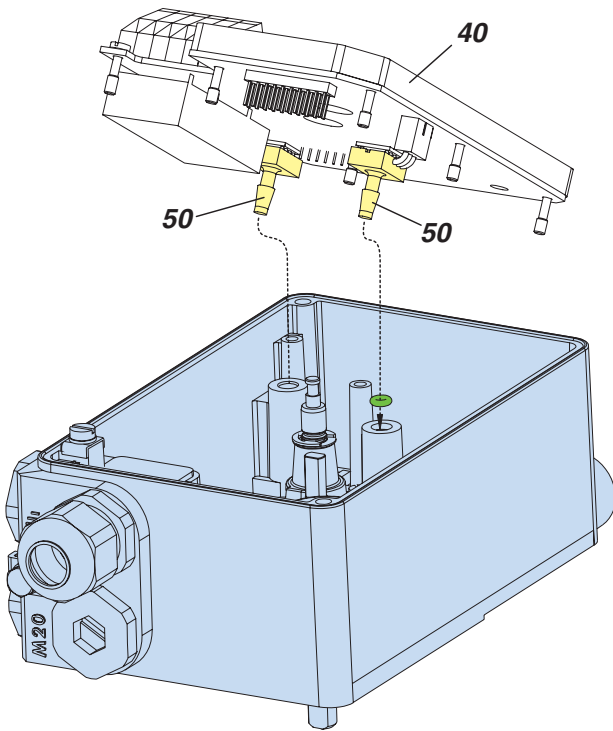

Pressure sensors 50

Additional Inputs / Outputs:

One module “Additional inputs / outputs” 8 can be plugged onto main electronics 40:

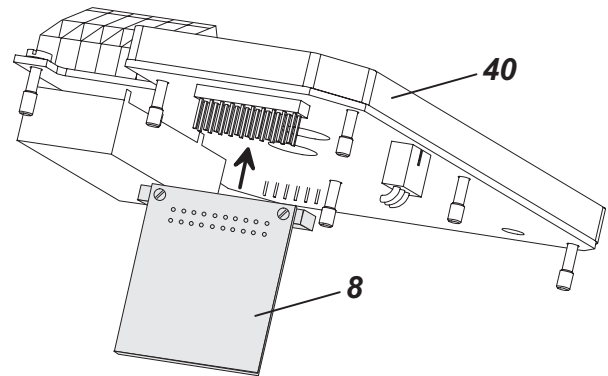

- 2 Binary inputs or
 - 2 Binary outputs or
 - 2 Binary in/outputs or
 - Position feedback and Alarm or
 - Potentiometer input
- Details see following pages.

Built-in Limit Switch

Built-in Limit signal switch B

Details see page 19.

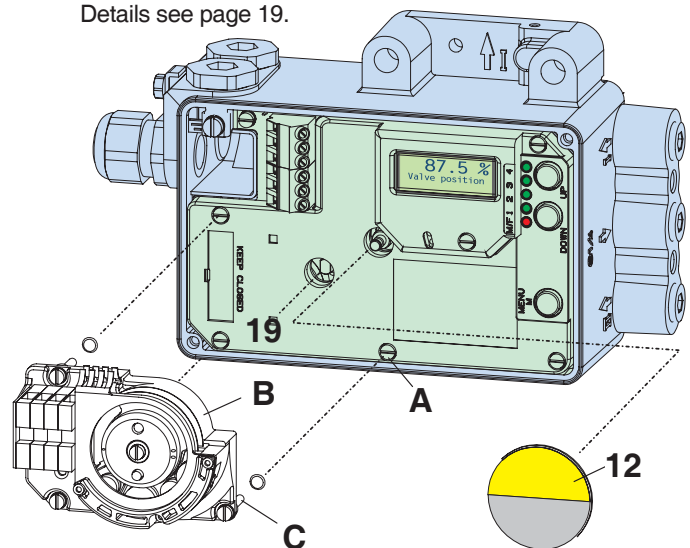

Parts Kits for additional installation of auxiliary functions

Model code	Supply	before HW-Rev. 3.0	from HW-Rev. 3.0
Additional inputs / outputs/ Limit signal switch			
Code B: Binary inputs (Contact inputs)	internal	EW 411 407 273	EW 411 407 325
Code E: 2 Binary in/outputs	external		EW 411 407 956
Code P: 2 Binary outputs	external	EW 411 407 264	EW 411 407 316
Code F: Position feedback 4-20 mA and Alarm (ATEX)	external		EW 411 407
Code Q: Position feedback 4-20 mA and Alarm (FM/CSA)	external	EW 411 407 255	EW 411 407 282
Code D: Entry for remote potentiometer	internal		EW 411 407
Code T: Limit signal switch, normal version	external	EW 426 164 012	EW 426 164 012
Code U: Limit signal switch, security version	external	EW 426 164 021	EW 426 164 021
Code R: Limit signal switch, 3-wire	external		EW 426 164 057
Code V: Limit signal switch, micro switches	external		EW 426 164 066

ADDITIONAL EQUIPMENT built into any basic device

Additional Inputs / Outputs:

Two Binary (Contact) inputs – Code B

Two independent binary inputs, supplied with the basic device, for connection of external switches.

A connected switch is loaded with 3.5 V, 150 μ A.

This option 'Binary inputs' can also be used to activate PST (Partial Stroke Test).

The binary inputs can be used for diagnostics or are also configurable for the control functions:

Switch 1	Switch 2	Actuator control function
close	close	normal operation
open	close	go to stop at 0 %
close	open	go to stop at 100 %
open	open	hold last position

Terminals for EB1 A: 13+

B: 14–

EB2 C: 15+

D: 16–

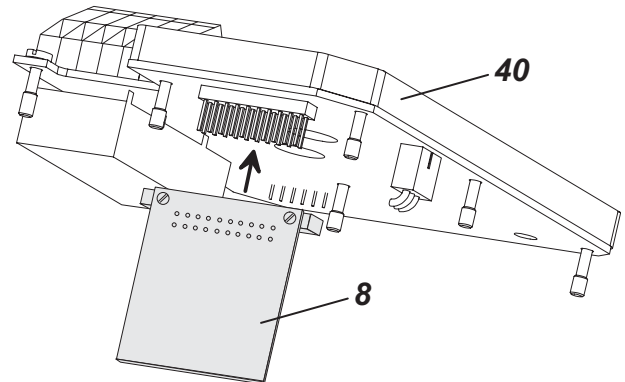

One module "Additional inputs / outputs" 8 can be plugged onto main electronics 40 :

- 2 Binary inputs or
- 2 Binary outputs or
- 2 Binary in/outputs or
- Position feedback and Alarm or
- Potentiometer input

Electrical Classification ATEX:

Types of protection and temperature classes of basic device, see page 9.

Additions for this option, Type AI 638 B, in EC- Certificate of Conformity PTB 00 ATEX 2128:

To this electric circuit only passive electric circuits galvanically separated from earth may be attached.

The electric circuit has the following maximum values:

$$U_o = 7.88 \text{ V}, I_o = 11.4 \text{ mA}, P_o = 23 \text{ mW}$$

Characteristic is linear

For the maximum values of outer inductances and capacities L_o and C_o refer to the following table (L_i and C_i included):

IIC		IIB	
L_o [mH]	C_o [μ F]	L_o [mH]	C_o [μ F]
100	0.72	100	3.9
10	1.1	10	5.5
1	1.6	1	8.7
0.1	2.7	0.1	15
0.01	4.7	0.01	27

The electric circuits of "2 binary inputs" are galvanically connected with all other circuits but separated from earth.

DTM Configuration window

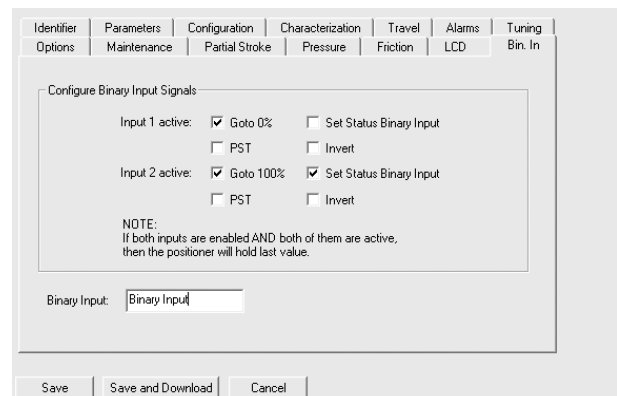

Additional Inputs / Outputs:

Two binary outputs (limit signals) – Code P

Stroke / angle derived from positioner feedback

2 galvanically separated limit signals

Signaling of limit value exceeding of the measured valve stem position.

Limit signals / alarms freely configurable via local keys or via communication.

Two-wire system, according to DIN 19234, for external supply.

supply voltage DC 8 ... 36 V ^{1) 2)}

Logic:

- limit value not exceeded . . . < 1 mA
- limit value exceeded. > 2.2 mA (typ. 6 mA)
- device fault. < 50 µA

configurable as switch output:

- limit value not exceeded . . . < 50 µA
- limit value exceeded. > 20 mA/20 V / > 40 mA/10 V (power derated)

Reference: AB1 for upper, AB2 for lower limit

Terminals for AB1³⁾ A: 81+

B: 82-

AB2³⁾ C: 83+

D: 84-

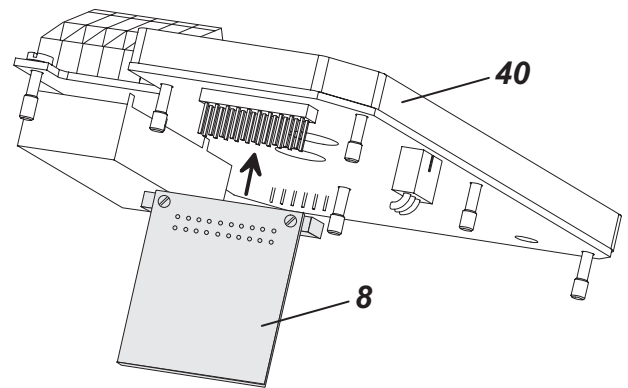

One module "Additional inputs / outputs" 8 can be plugged onto main electronics 40:

- 2 Binary inputs or
- **2 Binary outputs** or
- 2 Binary in/outputs or
- Position feedback and Alarm or
- Potentiometer input

Electrical Classification ATEX:

Types of protection and temperature classes as basic device, see page 9.

Additions for this option, Type AI 638 P, in EC- Certificate of Conformity PTB 00 ATEX 2128:

For use in hazardous areas in circuits certified as intrinsically safe with the following maximum values:

U_i= 16 V, I_i= 80 mA, P_i= 250 mW

Internal capacitance and inductance: C_i= 26 nF, L_i= 5 µH

The electric circuits of "2 binary outputs" are galvanically separated from all other circuits and from earth.

DTM Configuration window

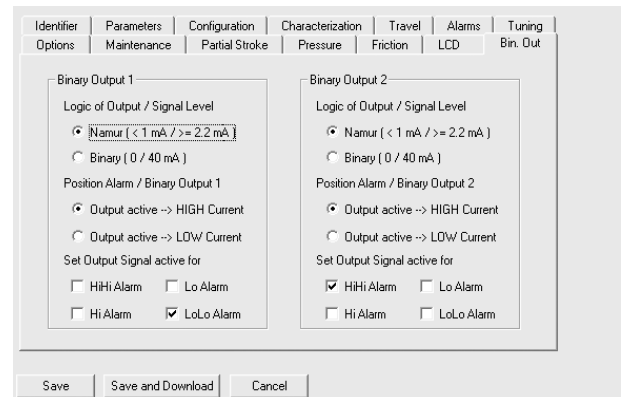

1) Other values in hazardous areas
 2) On request we can specify higher voltage limits
 3) Terminals 81 ... 84 are marked as K21 ... K32 within certificate of conformity.

Additional Inputs / Outputs:

Two binary in/outputs – Code E

This option board is recommended for PST applications.

Output:

2 galvanically separated signals

Limit signals / alarms freely configurable via local keys or via communication.

Two-wire system, according to DIN 19234, for external supply.

supply voltage DC 8 ... 36 V ^{1) 2)}

Configured as NAMUR signal:

Logic:

- limit value not exceeded . . . < 1 mA
- limit value exceeded. typ. 6 mA
- device fault. < 50 µA

Configured as On/Off signal:

- limit value not exceeded . . . < 50 µA
- limit value exceeded. > 20 mA/20 V / > 40 mA/10 V
(power derated)

Reference: AB1 for upper, AB2 for lower limit value

- Terminals for AB1³⁾ A: 81+
- B: 82-
- AB2³⁾ C: 83+
- D: 84-

Input:

The kind of Signals Input can be configured as On/Off or as NAMUR signal in accordance (DIN 19234)

Configured as NAMUR signal:

Unloaded supply voltage . . . > 8 V

Input

- Logic 0. > 0.35 mA, < 1 mA
- Logic 1. > 2.2 mA, < 6 mA
- Input current Limited to. approx. 6 mA

Configured as On/Off signal:

Input:

- Logic 0. < 4 mA
- Logic 1. > 6 mA
- Signal Voltage Range 8 ... 36 V¹⁾

Electrical Classification ATEX:

See PTB00ATEX 2128 Certificate

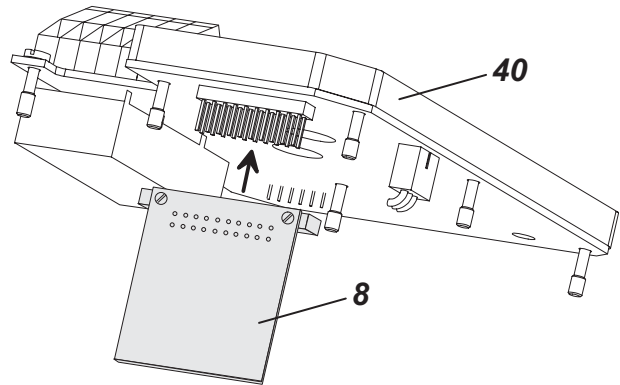

One module “Additional inputs / outputs” **8** can be plugged onto main electronics **40**:

- 2 Binary inputs or
- 2 Binary outputs or
- **2 Binary in/outputs** or
- Position feedback and Alarm or
- Potentiometer input

DTM Configuration window

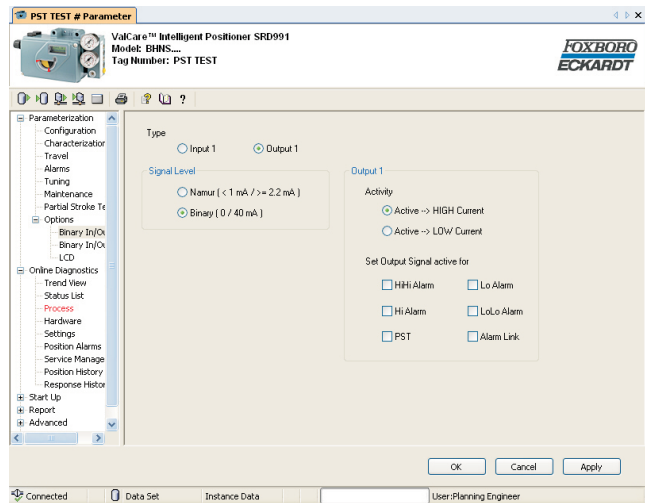

1) Other values in hazardous areas
 2) On request we can specify higher voltage limits
 3) Terminals 81 ... 84 are marked as K21 ... K32 whitin certificate of conformity.

Additional Inputs / Outputs:

Position feedback 4...20 mA and Alarm

- Code F with electrical classification ATEX
- Code Q with electrical classification FM/CSA

Stroke / angle derivated from positioner feedback
 1 output analog, galvanically separated, two-wire system according to DIN 19234, for external supply

- supply voltage DC 8 ... 36 V ^{1) 2)}
- signal range 3.8 to 20.5 mA
- 0 % and 100 % configurable
- device fault < 50 µA
- Terminals for AI1 C: 31+
- D: 32-

Feedback signal can be reversed (20-->4 mA).

1 binary alarm output, galvanically separated, two-wire system, according to DIN 19234, for external supply

- supply voltage external, DC 8 ... 36 V ^{1) 2)}
- Logic no alarm . . . < 1mA
- alarm > 3 mA
- device fault < 50 µA

configurable as switch output:

- limit value not exceeded . . . < 50 µA
- limit value exceeded. > 20 mA/20 V / > 40 mA/10 V (power derated)
- Terminals for AB1³⁾. A: 81+
- B: 82-

The binary output for Alarm will be activated in the following cases:

- Remaining control deviation
- Circuit to I/P module is disturbed
- Circuit to potentiometer is disturbed
- Calibration error:
 - no angle calibration
 - no current calibration
- Autostart failed

These pre-settings can be configured via communication with the Alarm Link function in the DTM.

Electrical Classification ATEX:

Types of protection and temperature classes as basic device, see page 9.

Additions for this option, Type AI 638 Q, in EC- Certificate of Conformity PTB 00 ATEX 2128:

For use in hazardous areas in circuits certified as intrinsically safe with the following maximum values:

U_i= 30 V, I_i= 130 mA, P_i= 0.9 W

Internal capacitance and inductance: C_i= 26 nF, L_i= 5 µH

The electric circuits of "Position feedback 4...20 mA" are galvanically separated from all other circuits and from earth.

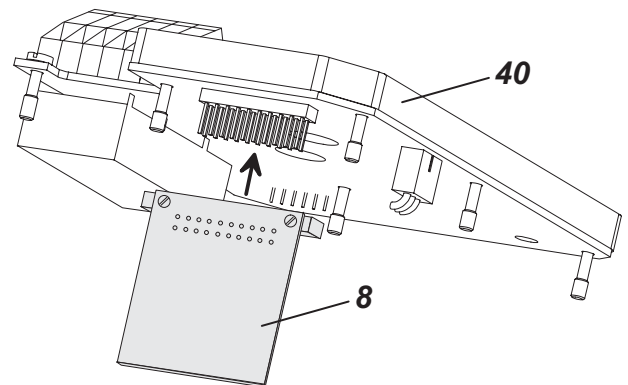

One module "Additional inputs / outputs" 8 can be plugged onto main electronics 40:

- 2 Binary inputs or
- 2 Binary outputs or
- 2 Binary in/outputs or
- **Position feedback and Alarm** or
- Potentiometer input

DTM Configuration window

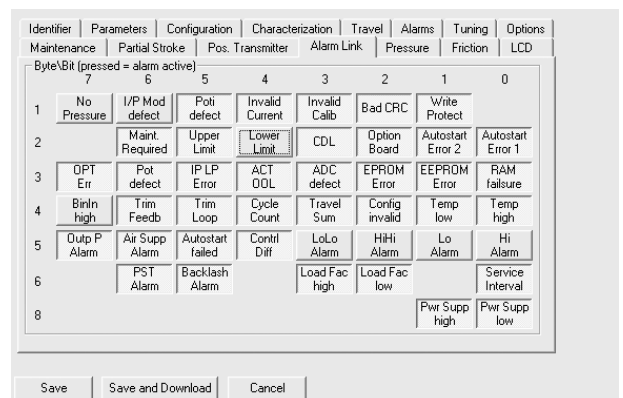
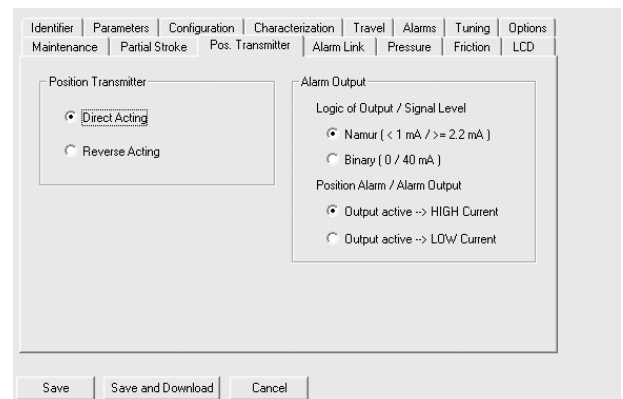

1) Other values in hazardous areas
 2) On request we can specify higher voltage limits
 3) Terminals 81 and 82 are marked as Terminals 21 and 22 in certificate of conformity

Entry for remote potentiometer
(for remote mounting main unit)

– Code D

This remote application is used in applications where high temperatures or vibration are present and can result in negative influences to the control. It can also be used in places not easy to reach, to ensure an easier handling of the unit, or for cylinders with large strokes.

The Positioner SRD991 (Remote unit) is mounted far away from the valve or cylinder in a safe environment.

The Potentiometer unit is mounted on the valve or cylinder. This potentiometer unit can be made of a derivativ version of the SRI990 positioner (only potentiometer in the housing) or of an external potentiometer like a linear potentiometer for application onto cylinders, for example.

This option is to be used with a potentiometer unit 3 wires system with ca. 5 kOhm resistance.

If the following requirements are observed, the set-up is insensitive to electrical disturbances caused by high electromagnetic fields, EMC and HF-radiation.

Cable Length max. 10 m (32 ft)

Cable Specification (not supplied by Foxboro Eckardt):

- 3-wire twisted pair, shielded
- shield needs to be connected on both ends to the internal ground
- shield endings need to be kept very short when connecting to the ground
- a HF cable gland is not required

For more information about remote mounting please consult TI EVE0105 R

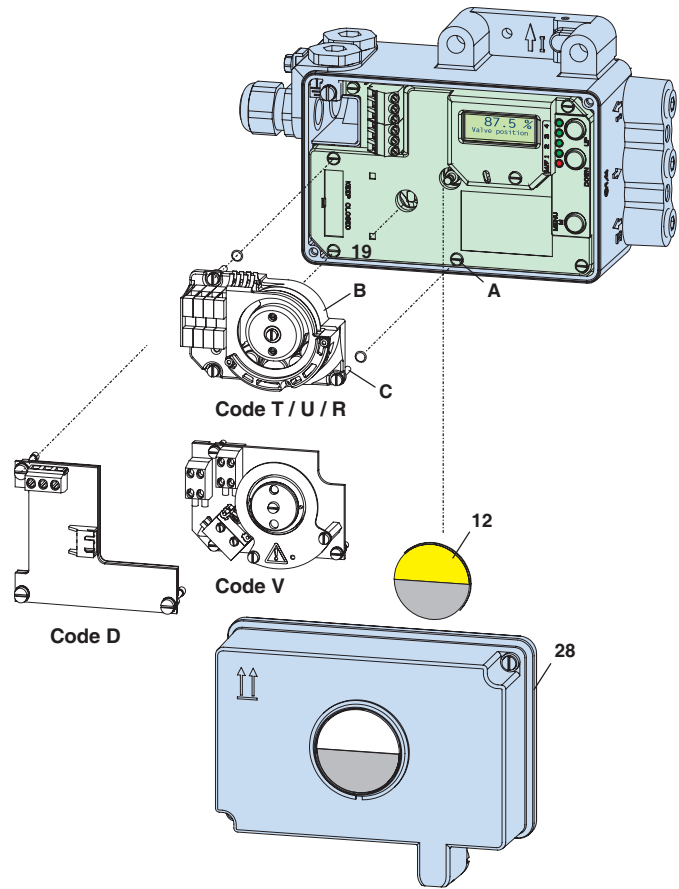

Built-in Limit Switches

- Stroke / angle derived from positioner feedback.
- standard version (SJ2-N) Code T (only to -20°C)
 - security version (SJ2-SN) Code U
 - 3-wire (SI2-K08-AP7/ PNP) Code R (no Ex)
 - Micro switches Code V (no Ex)
 - Entry for remote potentiometer . . . Code D

Materials

- Control vanes. Aluminum
- Transmission shaft. 1.4571

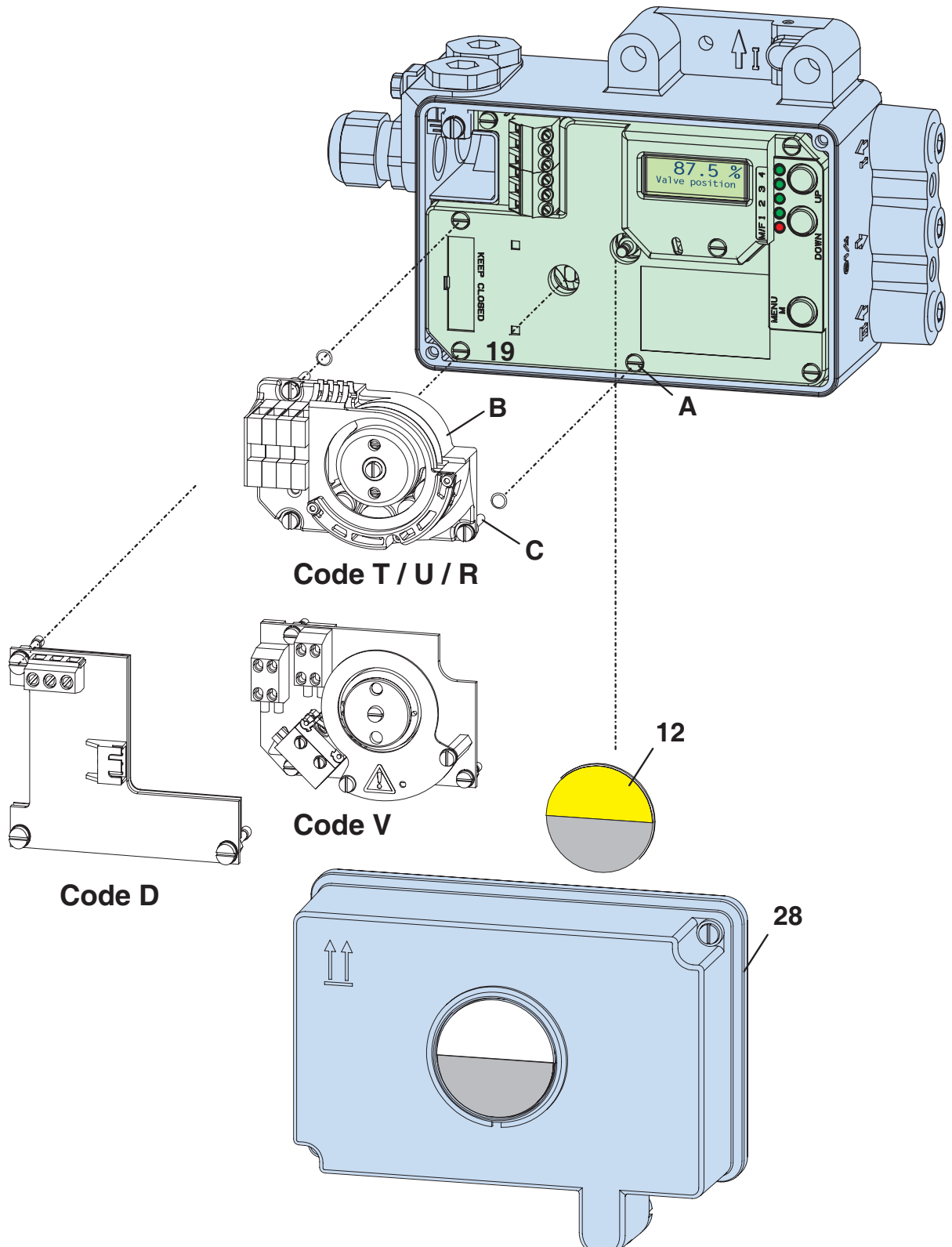

Inductive Limit Switch (Code T, U)

Output 2 inductive proximity sensors
acc. to DIN 19 234 or NAMUR for connection to
switching amplifier ¹⁾

Current consumption
vane clear > 2.2 mA
vane interposed < 1 mA

for control circuit with the following electrical values:
supply voltage DC 8 V, R_i approx. 1 kOhm
supply voltage range. DC 5...25 V (with "no Ex")
residual ripple < 10 % p.p.
permissible
line resistance < 100 Ohms

Response characteristic ^{2) 3)}
switching differential < 1 %
switching point repeatability < 0.2 %

Terminals for GW1 41+, 42-
GW2 51+, 52-

**Electrical Classification ATEX
of versions "T" and "U":**

Types of protection and temperature classes as basic device,
see page 9.

Additions for this option, Type AI 638 K, in EC- Certificate of
Conformity PTB 00 ATEX 2128:

Types of protection and temperature classes as basic device.
For use in hazardous areas in circuits certified as Intrinsically
Safe with the following maximum values:

U_i= 16 V, I_i= 25 mA, P_i= 64 mW

Internal capacitance and inductance: C_i= 30 nF, L_i= 100 µH
The electric circuits of "Built-in Limit Switch" are galvanically
separated from all other circuits and from earth.

Inductive Limit Switch, three-wire system

– Code R

Input Stroke / angle from actuator
via positioner feedback lever

Output 2 inductive proximity sensors,
three-wire system,
LED indication,
contact, pnp ²⁾

Supply voltage U_s DC 10 ... 30 V
Residual ripple ± 10 %, U_s = 30 V
Switching frequency 2 kHz
Constant current 100 mA
Response characteristic ⁶⁾
Gain continuously adjustable
from 1:1 to approx. 7:1

Switching differential < 1 %
Switching point
repeatability. < 0.2 %

Terminals for GW1 42
GW2 52
Supply. 41+, 43-

1) Operating mode min. (= low) / max. (= high)
selectable by adjustment of switch vanes

2) Data measured according to VDI/VDE 2177

3) With stroke 30 mm and lever length 90 mm

Mechanical Switches (Micro Switches) Code V

(only without Ex protection)

Stroke / angle derived from positioner feedback lever

Output 2 mechanical switches (Micro
switches) ^{5) 6)}

Manufacturer Saia-Burgess

Type V4NS-C4-AC1-UL
(UL- and CSA-approved)

Parts set for subsequent mounting:

Code V EW 426 164 066

Absolute limit values AC

of mechanical switches built into positioner:

U_{max}. 130 V AC ⁷⁾

I_{max} 0.5 A (resistive Load) ⁷⁾

I_{max} 0.03 A (inductive Load) ⁸⁾

Absolute limit values DC

of mechanical switches built into positioner: ⁹⁾

U_{max}. 30 V DC

I_{max} 1 A

Switching Differential: < 2.5 %

Terminals for SW1 41, 42

SW2 51, 52

The circuit of the mechanical switches have to be protected
by a suitable fuse. The diameter of the protective conductor
needs to be at least 1.5 mm² / AWG 16.

Input for Remote Potentiometer (code D)

This option is necessary when the positioner is not mounted
directly onto the valve but far away of it. In this case a
potentiometer with 3 wires must be mounted onto the valve
to give the valve position to the controller.

For more information regarding remote mounting please
consult TI EVE0105 R.

Remote potentiometer type to use in connection to this option:

Resistance of 5 kOhm up to 10 kOhm
(for other value of resistance please consult us).

If the following requirements are observed, the set-up is
insensitive to electrical disturbances caused by high
electromagnetic fields, EMC and HF-radiation.

Cable length max. 10 m (32 ft)

Cable specification (not supplied by Foxboro Eckardt):

- 3-wire twisted pair, shielded
- Shield needs to be connected on both ends to the internal
ground
- Shield endings need to be kept very short when connect-
ing to the ground
- A HF cable gland is not required

5) Operating mode min. (=low) / max. (=high) selectable by adjusting the
respective vane

6) Operating mode normally open / normally closed selectable by vane
adjustment

7) Approval according to UL (UL 1054) and CSA (CSA 22.2 No. 55) at
6,000 operations and T = 65 °C / 149 °F

8) Based on EN 61058-1, at 10,000 operations and T = 85 °C / 185 °F

9) General rating at 50,000 operations and T = 85 °C / 185 °F

FUNCTIONAL DESIGNATIONS

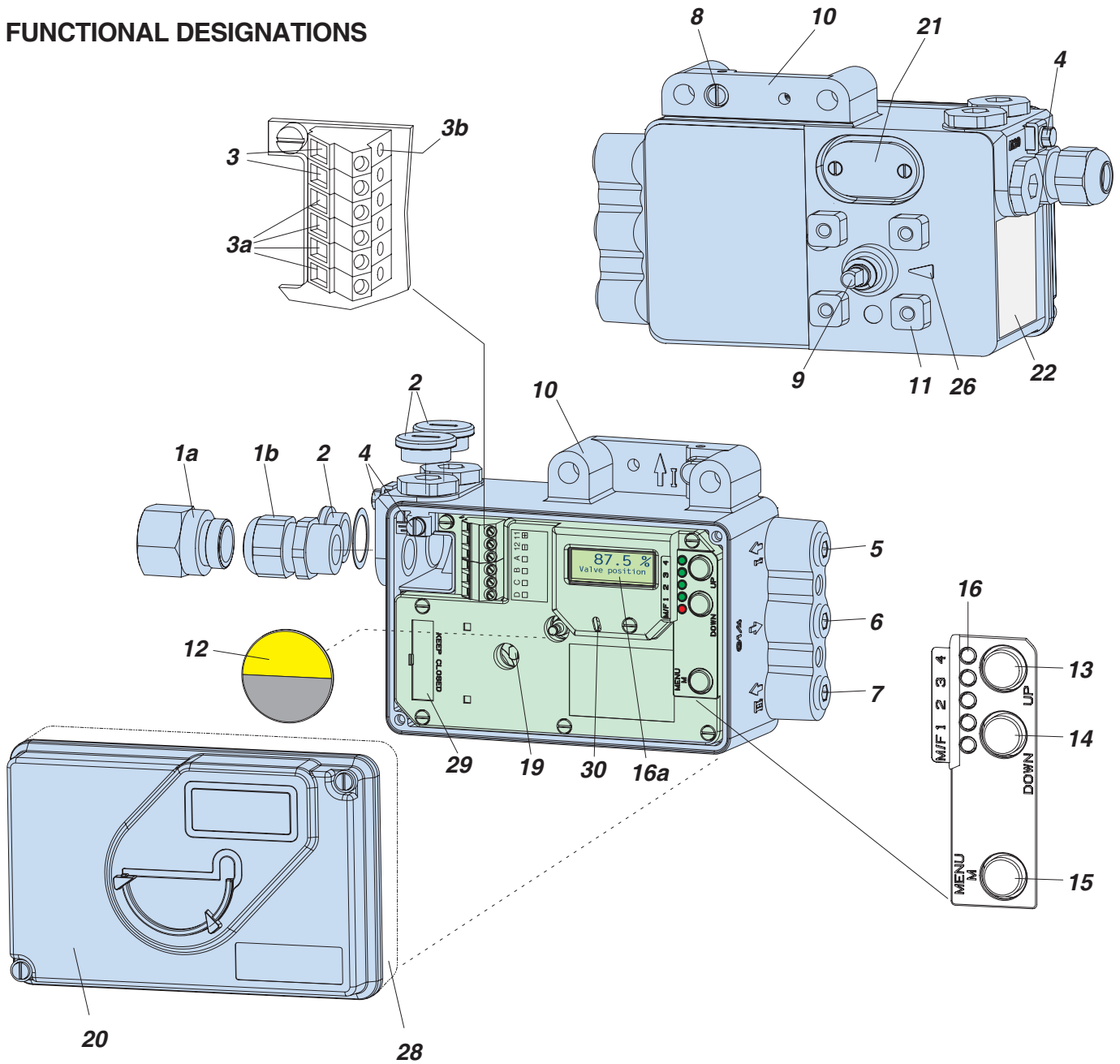

- 1a** Adapter, eg. 1/2"-14 NPT
- 1b** Cable gland
- 2** Plug, interchangeable with Pos. **1**
- 3** Screw terminals ¹⁾ (11 / 12) for input (w) or for bus connection IEC 1158-2
- 3a** Screw terminals ¹⁾ for additional inputs / outputs
- 3b** Test sockets Ø 2 mm, integrated in terminal block
- 4** Ground connection
- 5** Female thread G 1/4 for output I (y1)
- 6** Female thread G 1/4 for air supply (s)
- 7** Female thread G 1/4 for output II (y2)
- 8** Direct attachment hole for output I (y1)
- 9** Feedback shaft
- 10** Connection manifold for attachment to stroke actuators (not with VDI/VDE 3847 version)
- 11** Connection base for attachment to rotary actuators
- 12** Travel indicator
- 13** Key UP
- 14** Key DOWN
- 15** Key M (Menu)
- 16** Status display (1 red LED, 4 green LEDs)
- 16a** LCD with true text in 3 different languages
- 19** Fixing shaft for limit switch
- 20** Cover with window to **12**
- 21** Air vent, dust and water protected
- 22** Data label
- 26** Arrow is perpendicular to shaft **9** at angle 0 degree
- 28** High cover with built-in limit switch
- 29** Plug for service connector
- 30** IrCom interface

1) Alternatively WAGO terminals instead of screw terminals

MODEL CODES SRD991

Intelligent Positioner	SRD991									171209
VERSION										
Single Acting		-B								
Double Acting		-C								
Input/Communication										
Intelligent without communication (4 - 20 mA)		D								
HART Communication (4 - 20 mA)		H								
FoxCom Communication (Digital/IT2)		F								
PROFIBUS-PA (acc. to FISCO)		P								
FOUNDATION Fieldbus H1 (incl. PID-Function Block, acc. to FISCO)		Q								
Additional Inputs/Outputs										
Prepared For Additional In-/Outputs		N								
Two Binary Outputs		P								
Position Feedback 4 - 20 mA and one Binary Output for Alarm (ATEX)		F								
Position Feedback 4 - 20 mA and one Binary Output for Alarm (FM/CSA)		Q								
Binary Inputs (z)		B								
Sensor Input (b)		C								
Binary Inputs-Outputs (mandatory for ESD application) (z)		E								
Built-In Limit Switch										
Without Built-In Limit Switch		S								
Inductive Limit Switch - Intrinsically Safe (Standard Version SJ2-N)		T								
Inductive Limit Switch - Intrinsically Safe (Security Version SJ2-SN)		U								
Inductive Limit Switch - Three wire version (u)		R								
Mechanical Switches (Micro-Switches) / UL- and CSA-approved (u)		V								
Potentiometer Input - CEM Filter (for Remote Mounting - main unit) (t)(k)		D								
Cable Entry										
M20 x 1.5 Without Cable Gland								1		
1/2"-14 NPT (with Adapter(s) M20x1.5 to 1/2"-14 NPT)								6		
M20 x 1.5 With One Plastic Cable Gland								7		
Electrical Classification										
Without Ex.									ZZZ	
for Input/Communication D, H. (y)										
for Input/Communication H, F (x)										
EEx ia IIC T4 according to ATEX (c)									EA4	
II 2 G EEx ia IIC T6 according to ATEX (d)									EAA	
II 2 G EEx ia IIC T4 according to ATEX + Zone 20 Dust (c)									ED4	
II 2 G EEx ia IIC T6 according to ATEX + Zone 20 Dust (d)									EDA	
FM Nonincendive For Class I, Division 2, Groups A, B, C, D, Hazardous Locations Indoors And Outdoors, NEMA 4X									NFM	
for Input/Communication D, H. (y)										
FM Approved For Intrinsic Safety Class I, Division 1, Groups A, B, C, D, Hazardous Locations Indoors And Outdoors, NEMA 4X									FAA	
for Input/Communication D, H. (y)										
CSA Approved For Intrinsic Safety Class I, Division 1, Groups A, B, C, D, Hazardous Locations Indoors And Outdoors, NEMA 4X									CAA	
for Input/Communication D, H. (y)										
GOST Approved For Intrinsic Safety ExialICT4 (c)									GA4	
GOST Approved For Intrinsic Safety ExialICT6..T4 (d)									GAA	
Attachment Kit										
Order as Auxiliary									N	
Manifold										
Pneumatic connection 1/4 - 18 NPT made of an additional manifold									Y	
Pneumatic connection G 1/4.									R	
(continued on next page)										

MODEL CODES SRD991 (continued)

OPTIONS

Premium Diagnostics made with built-in Pressure Sensors . . . (v)	-B
Positioner free of copper and its alloys (h)	-C
Infrared Interface For Communication By Means Of IRCOM . . . (s)	-I
Pneumatic Amplifier in the "Spool Valve" Version (n)	-S
Approved for SIL2 / SIL3 application (w)	-Q
Custom Configuration	-T
Version of Positioner according to VDI/VDE 3847.	-N
Version for ESD Valve with PST functionalities (a)	-E
Stainless Steel Housing (f)	-Z
Stainless Steel Housing without SST gauges (f)	-Z1
LCD with Menu-Language in English / German / French.	-V01
LCD with Menu-Language in English / German / Spanish	-V02
LCD with Menu-Language in English / German / Portuguese	-V03
LCD with Menu-Language in English / German / Polish	-V04
LCD with Menu-Language in English / German / Czech	-V05
LCD with Menu-Language in English / German / Italian	-V06
LCD with Menu-Language in English / German / Turkish	-V07
LCD with Menu-Language in English / German / Swedish	-V08
LCD with Menu-Language in English / German / Finnish	-V09
LCD with Menu-Language in English / German / Chinese. . . (b)	-V10
LCD with Menu-Language in English / German / Russian	-V11
LCD with Menu-Language in English / German / Hungarian	-V12
LCD with Menu-Language in English / German / Serbian	-V13
LCD with Menu-Language in English / German / Dutch	-V14
LCD with Menu-Language in English / German / Romanian	-V15
Tag No. Labeling	
Stamped With Weather Resistant Color	-G
Stainless Steel Label Fixed With Wire	-L

- (a) ONLY WITH (Version: B) AND (additional Inputs/Outputs: E) AND (Optional Feature: -B)
- (b) Not released
- (c) Only with Input/Communication D, H
- (d) Only with Input/Communication F, H, P and Q
- (f) Available WITH (Version: C) AND (Built-in Limit Switch: S) AND (Electrical Classification: ZZZ, EA4, EAA, GA4, GAA) AND (Manifold: Y) AND (Optional Features: S) OR WITH (Version: B) AND (Built-in Limit Switch: S) AND (Electrical Classification: ZZZ, EA4, EAA, GA4, GAA) AND (Manifold: Y)
- (h) Available WITH (Version: B) OR WITH (Version: C) AND (Optional Features: S)
- (k) Only with ELECTRICAL CLASSIFICATION EA4, EAA, ZZZ
- (n) Only with Version -C
- (s) Only available with Optional Feature LCD (-V01 to -Vxx)
- (t) Not with Additional Input/Outputs D
- (v) Only available for (Input/Communication F, H, P, Q) AND (Electrical Classification ZZZ, FAA, NFM EAA, CAA, GAA)
- (w) Only available for (Version single-acting -B) AND (Input/Communication D, H)
- (x) Only in connection with Optional Features -B
- (y) Not with Optional Features -B
- (z) Not available with Electrical Classification FAA, NFM, CAA

Accessories, for all basic devices

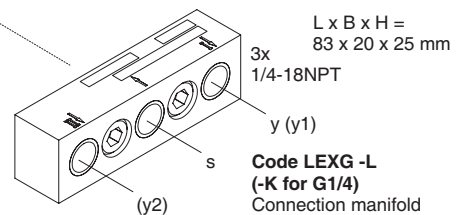
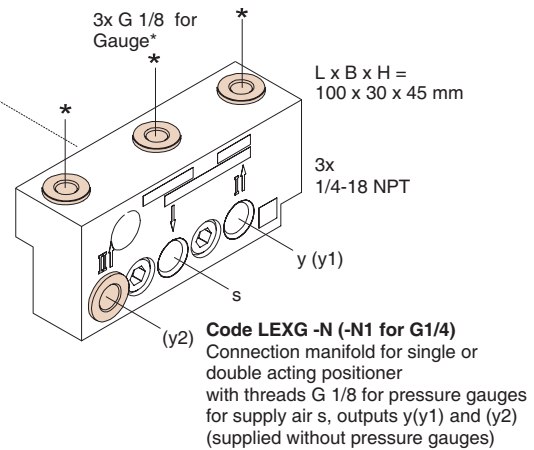
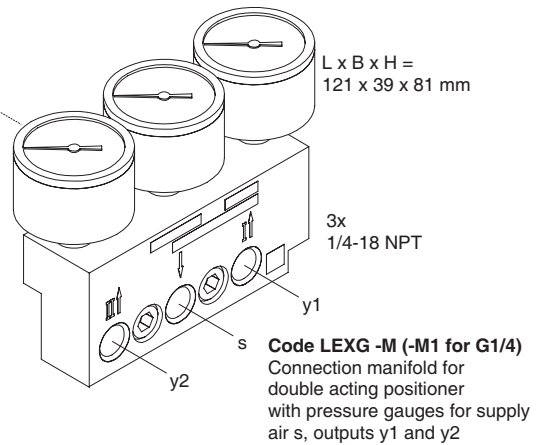
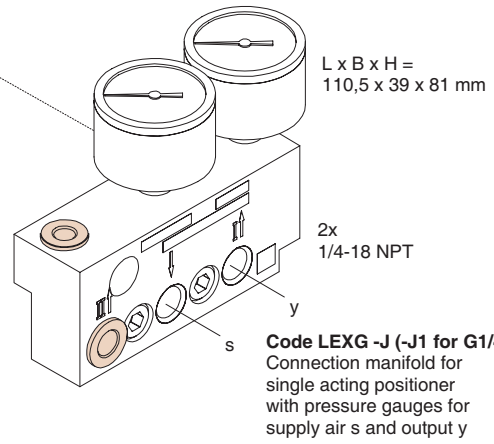
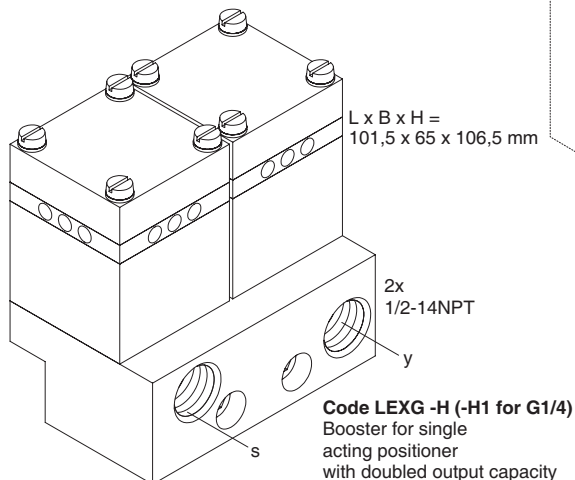
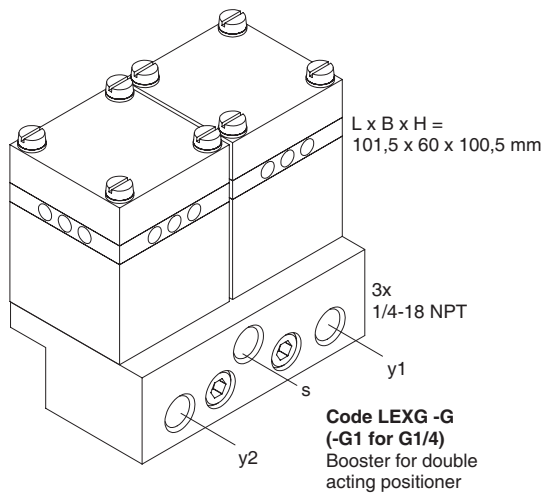
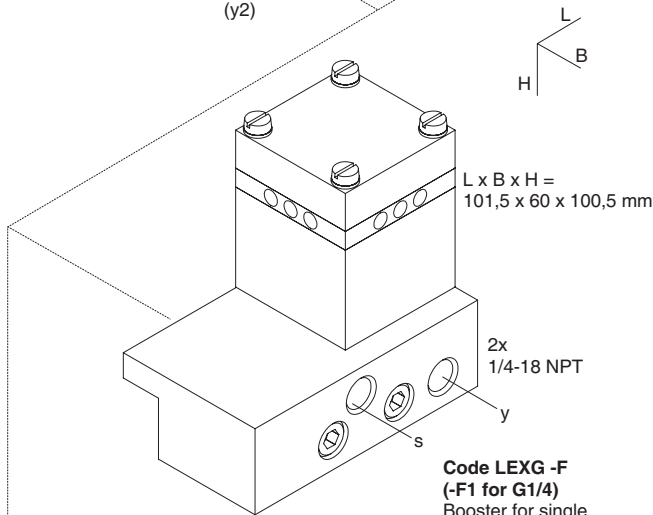
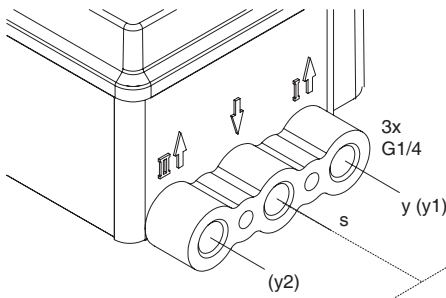

* Unused threads for pressure gauges are closed by means of lock screw Part No. 425 024 013.

1) Note: Booster manifold or Gauge manifold - not both.

Model Codes Accessories

Accessories for intelligent Positioners	
Cable Gland	BUSG
M20 x 1.5 stainless steel	-S6
M20 x 1.5 plastic, color gray	-K6
M20 x 1.5 plastic, color blue	-K7
M20 x 1.5 plastic, color white	-K9
M20 x 1.5 HF-cable gland for Fieldbus	-P4
M20 x 1.5 Plug-connector for Fieldbus (ss / threaded connection 7/8 - UN)	-F2
M20 x 1.5 Plug-connector for Fieldbus (ss / threaded connection M12)	-P3
M20 x 1.5 stainless steel EEx d	-S7
M20 x 1.5 brass zink plated EEx d	-S8
1/2-14 NPT cable gland 6...12 mm, Stainless steel, EEx d	-N1
1/2-14 NPT cable gland 6...12 mm, Steel zink plated, EEx d	-N2
1/2-14 NPT, brass zink plated, EEx d	-N3
M20 x 1.5 Plug, plastic	-V3
M20 x 1.5 Plug, EEx d / explosionproof certified, stainless steel	-V4
1/2-14 NPT Plug, EEx d / explosionproof certified, stainless steel	-V5
M20 x 1.5 Plug, brass zink plated, EEx d	-V6
1/2-14 NPT Plug, brass zink plated, EEx d	-V7
Adapter	AD
Adapter 1/2" NPT to 3/4" NPT (stainless steel)	-A3
Adapter M20 x 1.5 to 1/2" - 14 NPT (internal thread) (Brass nickel plated)	-A5
Adapter M20 x 1.5 to 1/2" - 14 NPT (internal thread) (stainless steel)	-A6
Adapter M20 x 1.5 to PG13.5 (internal thread) (stainless steel)	-A7
Adapter M20 x 1.5 to G1/2" (internal thread) (stainless steel)	-A8
Adapter (plastic) M20 x 1.5 to PG13.5 (internal thread)	-A9
Manifold (for SRD960, SRD991 and SRI990)	LEXG
With Connection G 1/4	-K
Gauge Manifold (for SRD960, SRD991 and SRI990 with 1/4 - 18 NPT connection)	
Without gauges	-N
With gauges for Version single acting	-J
With gauges for Version double acting	-M
with G1/4 connection)	
Without gauges	-N1
With gauges for Version single acting	-J1
With gauges for Version double acting	-M1
Booster Relay (for SRD960, SRD991 and SRI990, with connection 1/4 - 18 NPT)	
for Version single acting	-F
for Version double acting	-G
for Version single acting with doubled output capacity	-H
with connection G1/4 - 18	
for Version single acting	-F1
for Version double acting	-G1
for Version single acting with doubled output capacity	-H1
Booster Relay (mounted independent from positioner, for SRD960, SRD991 und SRI990, with connection G1/4)	
for Version single acting	-X1
for Version double acting	-Y1
for Version single acting with doubled output capacity	-Z1
(continued next page)	

MODEL CODES Attachment kits

ACCESSORIES FOR POSITIONER (SRD991, SRI990, SRD960)		012007
Attachment Kit		EBZG
For diaphragm actuators with casting yoke acc. NAMUR (incl. standard Couple lever)		-H
For diaphragm actuators with pillar yoke acc. NAMUR (incl. standard Couple lever)		-K
For directly mounting (incl. standard Couple lever)		-D
For mounting to rotary actuators acc. VDI/VDE 3845 (without bracket)		-R
For FoxTop / FoxPak (g)		-E
Brackets VDI/VDE 3845 (A = 130 mm/5.12 in; B = 50 mm/1.97 in)		-C3
Brackets VDI/VDE 3845 (A = 80 mm/3.15 in; B = 30 mm/1.18 in)		-C2
Brackets VDI/VDE 3845 (A = 80 mm/3.15 in; B = 20 mm/0.79 in)		-C1
For Badger Meter - Research Control Series 754 and 755 Size 1/2 inch		-B1
For Fisher 657, 667 (linear) size 30 and 40		-F1
1051, 1052, 1061 size 40		-F2
657, 667 size 30 and 60		-F3
657, 667 size 70 and 100		-F4
1051, 1052, 1061 size 33		-F5
1051, 1052, 1061 size 60		-F6
For Foxboro P-Series / such as -H with installed height 80 mm/3.15 in		-H1
NAMUR-Attachment kit for centered mounting position on the casting yoke		-H2
For mounting on ADAR control valve		-H3
micro flow control valve (k)		-H4
Such as -K with installed height 80 mm/3.15 in		-K1
For Kinetrol (Actuator Size 05)		-K2
(Actuator Size 07)		-K3
(Actuator Size 09)		-K4
For Metso / Neles Rotary actuators Type AB6 and Type BJ & BC size 8 and 10, B1C11		-L1
Type BJ and BC size 12 and 16, B1C17		-L2
For ARI-Armaturen - Direct Mounting to actuator type DR		-P1
For ARCA - Direct Mounting to actuator type BR 812		-P2
For Samson Type 3277 with 1/4 - 18 NPT		-S1
Type 3277 with G 1/4		-S2
Type 3277 with 1/4 - 18 NPT and gauges for supply- and output-pressure (g)		-S5
Type 3277 with G 1/4 and gauges for supply- and output-pressure (g)		-S6
Micro flow Type 3277-5 (k)		-S8
Tufflin / XOMOX Type MX60 (h)		-T1
Type MX200 (h)		-T2
Type MX450 / Typ MX750 / Typ MX1250 (h)		-T3
Type MX3000 (h)		-T4
For Hagan actuators (left of pneumatic cylinder)		-X2
(right of pneumatic cylinder)		-X1
For AMRI rotary actuator (requires minor modification of actuator. Please consult ECKARDT production before ordering!)		-X3
For Siemens actuators V-Series		-S3
For Sereg Maxflo, Revca, Reglob new type		-S4
Maxflo "old type"		-S7
CNX (Flowserve)		-S9
For Masoneilan Type Camflex II		-M
47/48 (Sigma-F)		-M1
Type 37/38 size 15 and 18 (complete kit)		-M2
Type 87/88 all size		-M4
Varipac		-M5
37/38 size 9, 11, 13		-M6
/ Severn Glocon Type Domotor size small (h)		-M7
For Valtek Linear Actuator all Sizes - Stroke up to 4 inch / 102 mm		-V1
For VETEC Type R150		-V2

*) We recommend to contact our field service dept. before selection of these mounting kits.

Further Attachment kits on request. See also [http://www.foxboro-eckardt.com /Products/Positioners/Attachment kits](http://www.foxboro-eckardt.com/Products/Positioners/Attachment%20kits)

MOUNTING TO LINEAR ACTUATORS

Attachment to stroke actuators acc. to IEC 534-6 (NAMUR), left hand

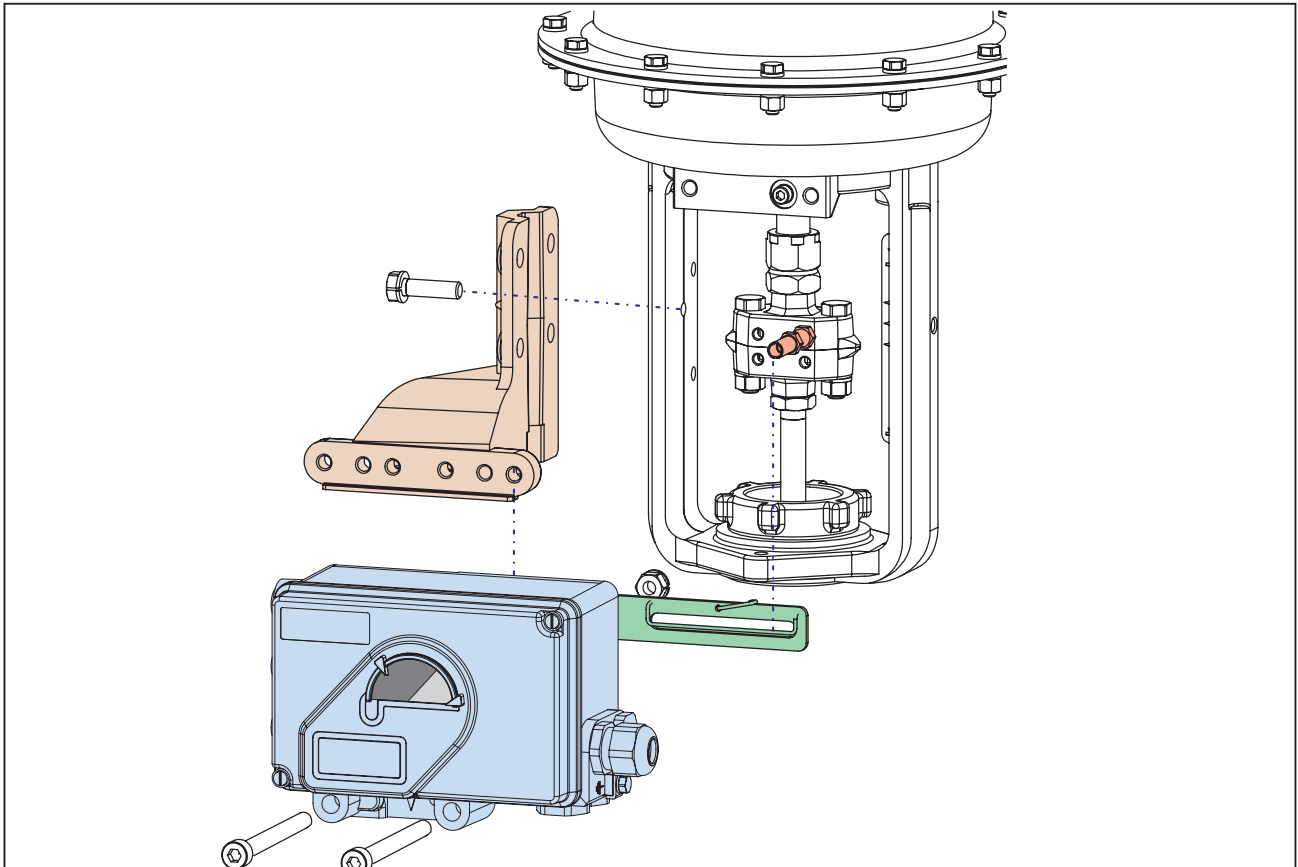

MOUNTING TO LINEAR ACTUATORS

Direct attachment to stroke actuators

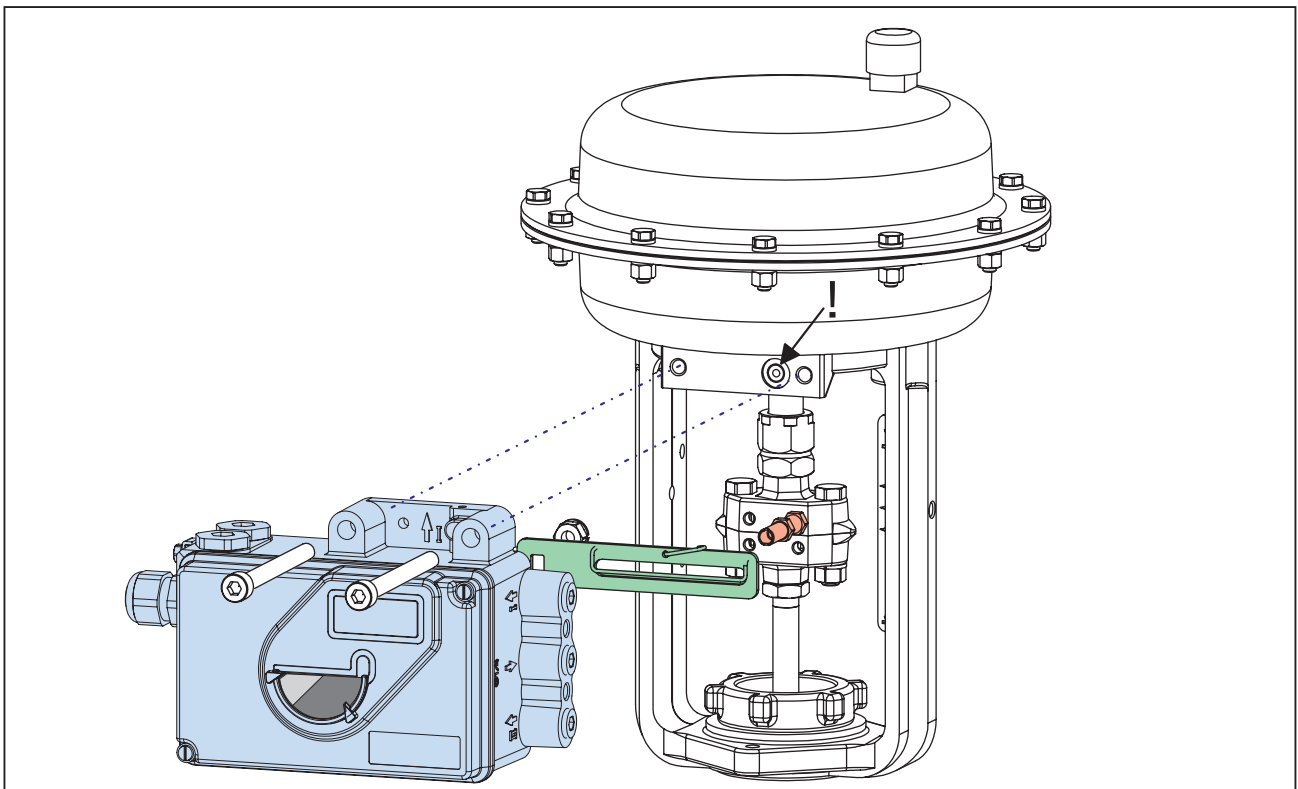

MOUNTING TO LINEAR ACTUATORS

Attachment to stroke actuators acc. to IEC 534-6 (NAMUR), right hand

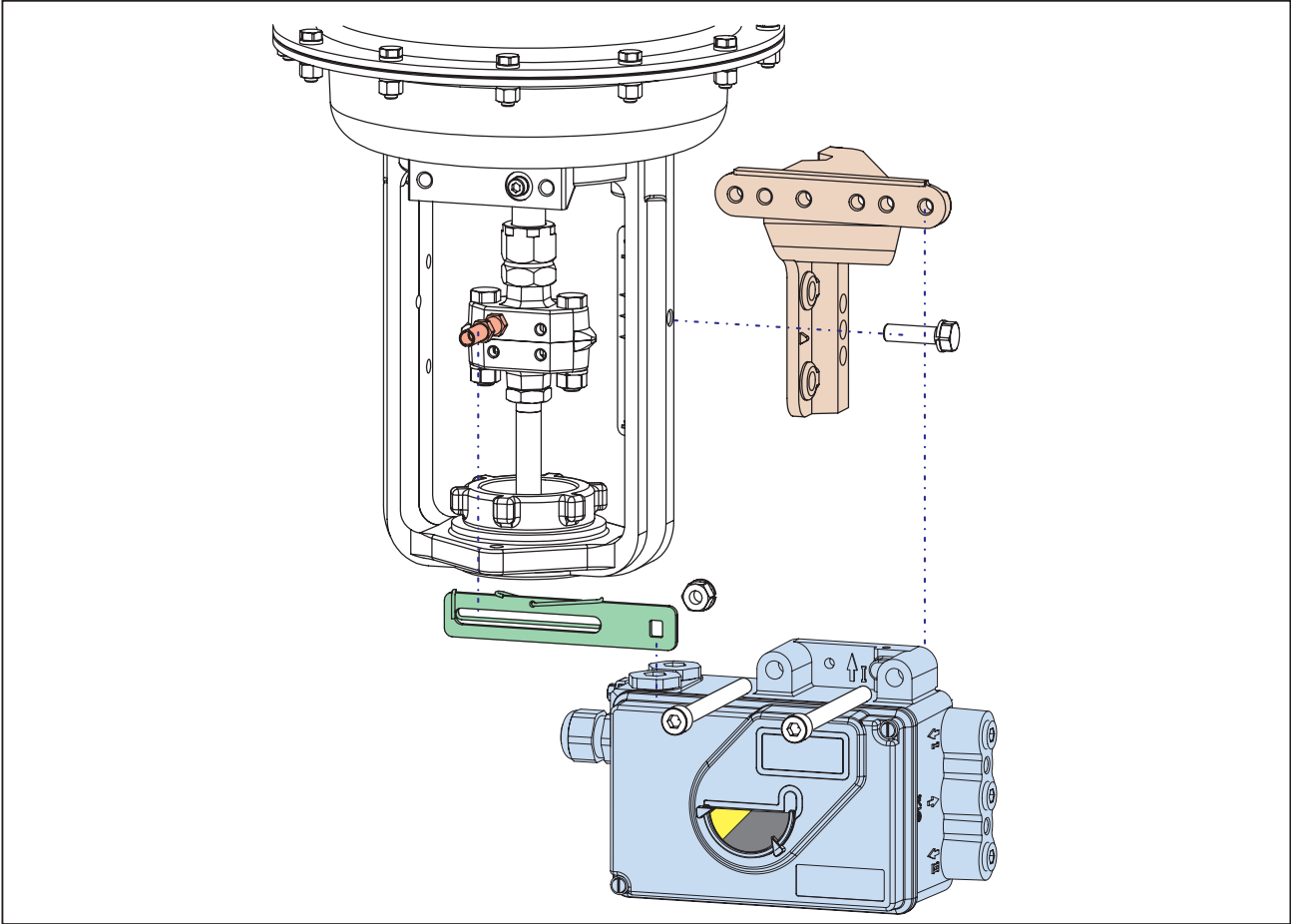

MOUNTING TO ROTARY ACTUATORS

Delivery of bracket by manufacturer of actuator

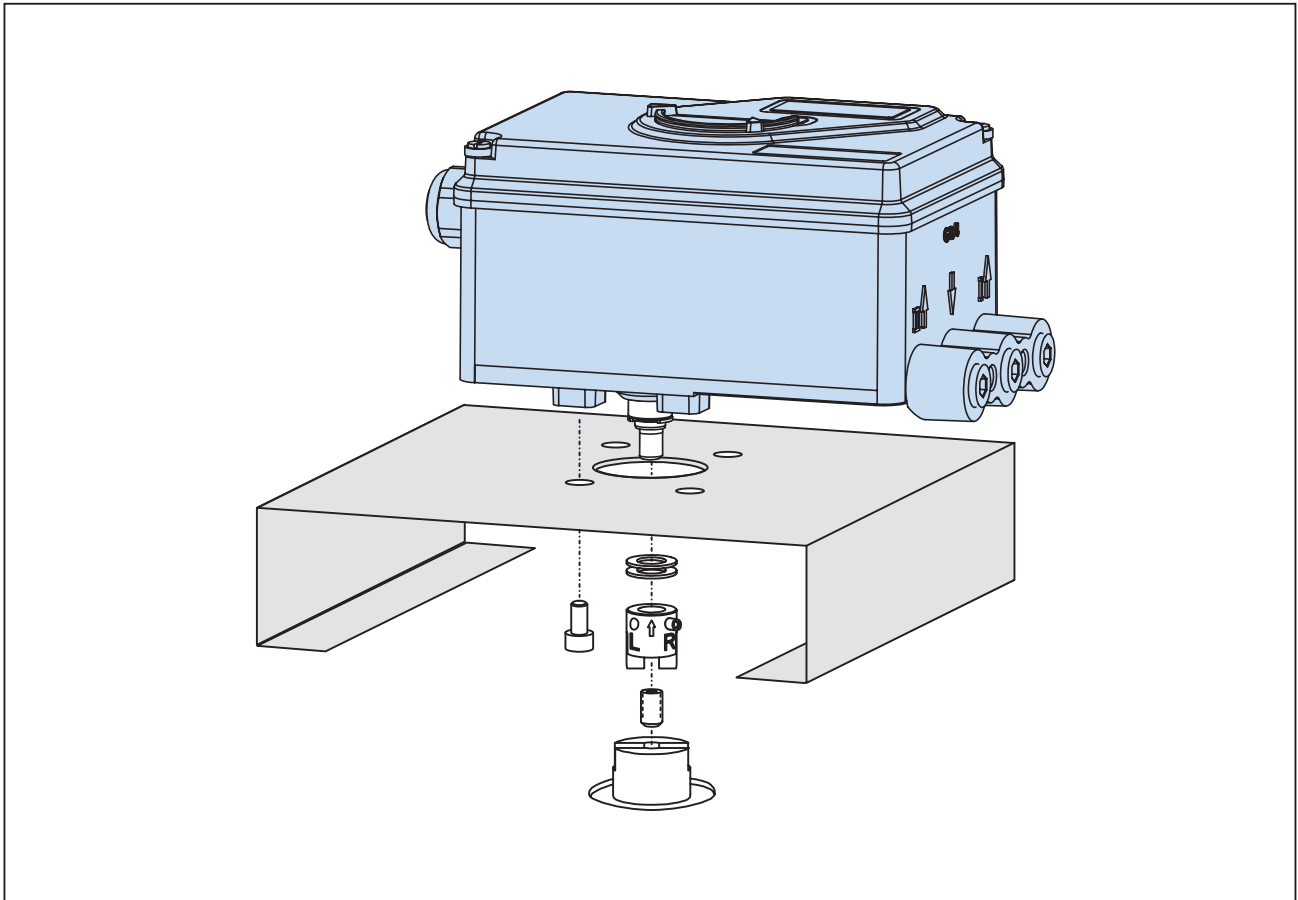

DIMENSIONS – Attachment to rotary actuators acc. to VDI/VE 3845

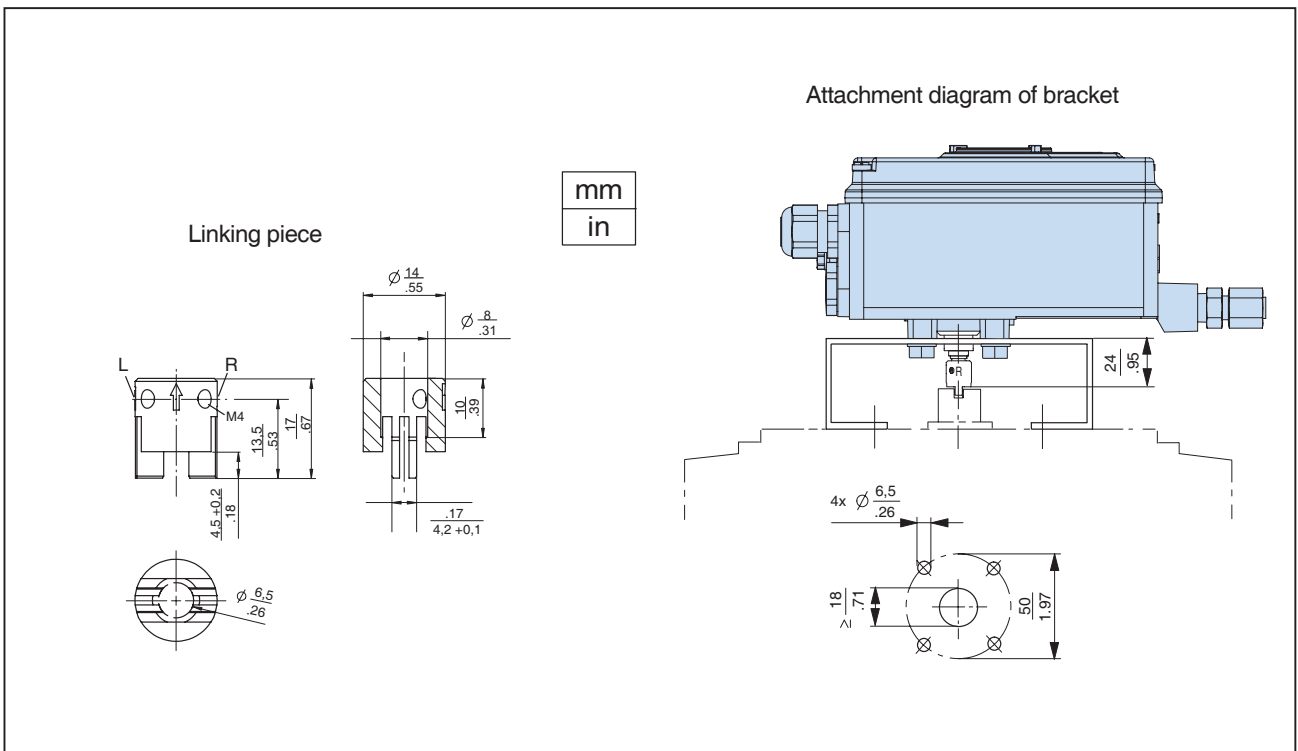

MOUNTING acc. to VDI/VDE 3847

Mounting to Linear Actuators

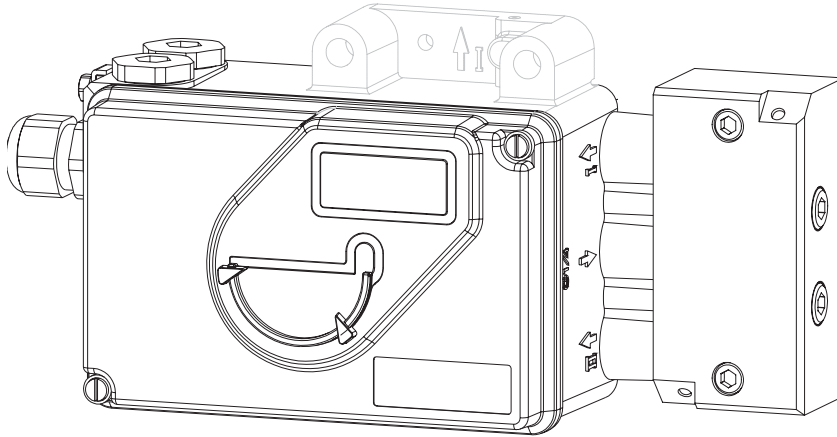

Mounting to Rotary Actuators

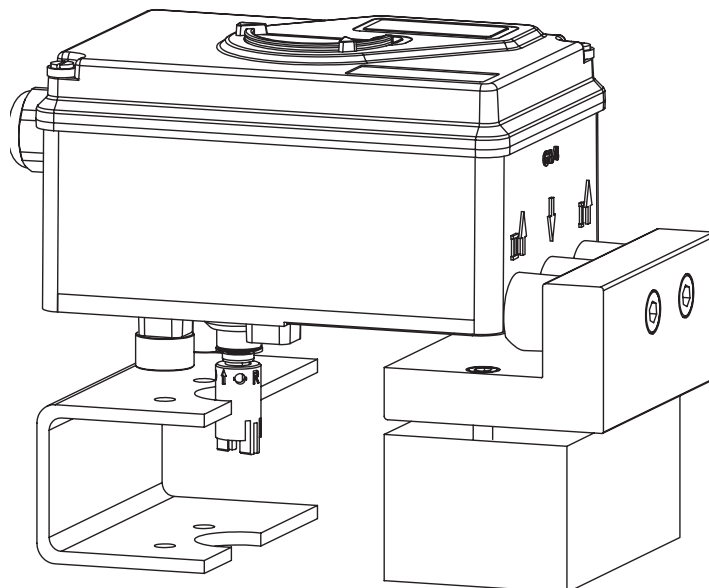

DIMENSIONS

Components of Attachment kits (samples)

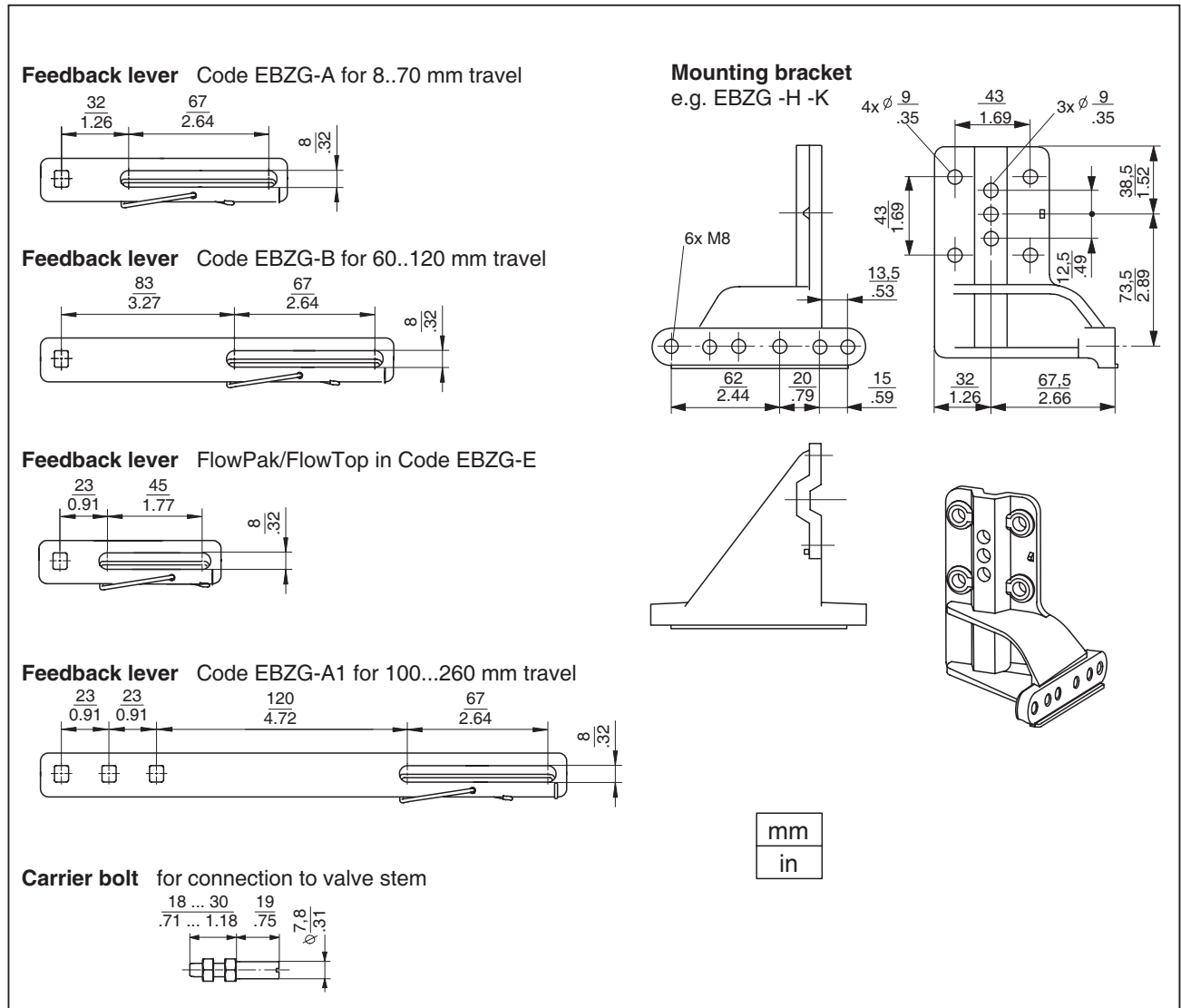

Weights of LEXG manifolds

- LEXG -F = 0.90 kg
- LEXG -F1 = 1.00 kg
- LEXG -G = 1.25 kg
- LEXG -G1 = 1.38 kg
- LEXG -H = 1.40 kg
- LEXG -H1 = 1.55 kg
- LEXG -J/-J1 = 0.40 kg
- LEXG -M/-M1 = 0.45 kg
- LEXG -N/-N1 = 0.28 kg
- LEXG -K = 0.12 kg

DIMENSIONS

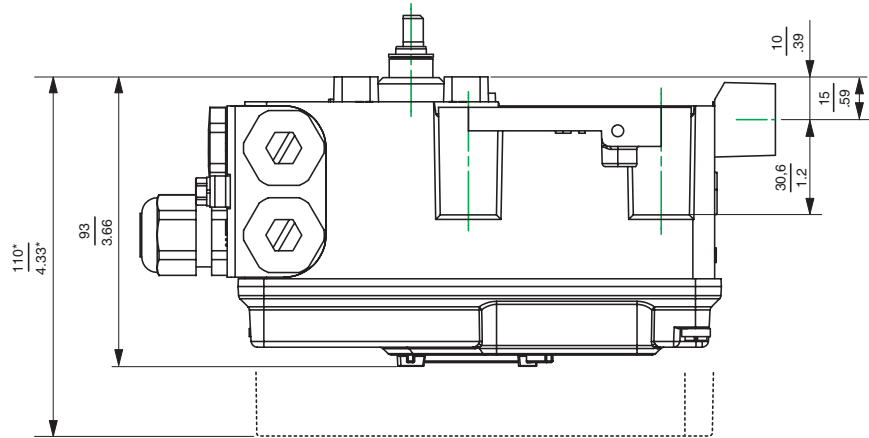
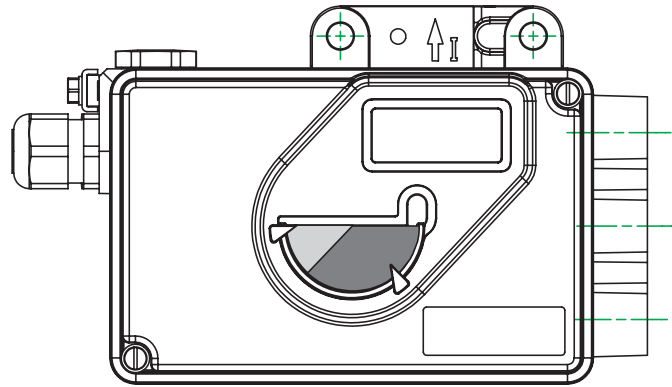
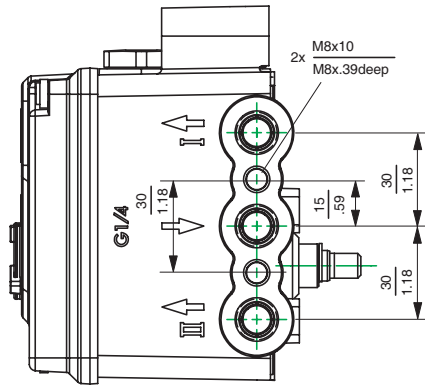

mm
in

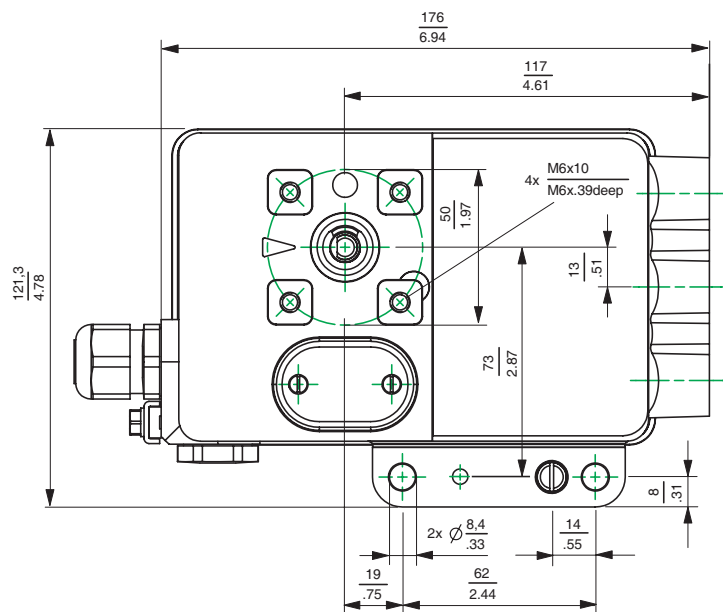

*) Dimensions with high cover for optional "limit switch"

Additional Documentation for this product

Technical Information of Attachment Kits for Positioners:

TI EVE0011 A Overview of Attachment Kits of all positioners on actuators/valves of different manufacturers

Quick Guide:

QG EVE0105 A Extract of Master Instruction for an easily to use, easy understandable and fast start-up.
This document highlights the most important aspects.

Master Instructions:

MI EVE0105 E SRD991 – all versions –

Technical Information for Fieldbus-Communication:

TI EVE0105 P SRD991/960 -PROFIBUS-PA

TI EVE0105 Q SRD991/960 -FOUNDATION Fieldbus H1

Master Instruction for HART-Communication:

MI EVE0105 B HART with Hand-Held Terminal

Valve diagnostic-, configuration- and operation-software VALcare™:

MI EVE0501 V VALcare™ Valve diagnostic for Positioners
HART / FoxCom / PROFIBUS-PA, FOUNDATION Fieldbus and IRCOM

Additional Documentation for other products

Product Specifications

PSS EVE0101 A SRP981 Pneumatic Positioner
 PSS EVE0102 A SRI986 Electro-Pneumatic Positioner
 PSS EVE0103 A SRI983 Electro-Pneumatic Positioner- explosion proof or EEx d version
 PSS EVE0105 A SRD991 Intelligent Positioner
 PSS EVE0107 A SRI990 Analog Positioner
 PSS EVE0109 A SRD960 Universal Positioner
 PSS EMO0100 A Accessories for devices with HART Protocol

Subject to alterations - reprinting, copying and translation prohibited. Products and publications are normally quoted here without reference to existing patents, registered utility models or trademarks. The lack of any such reference does not justify the assumption that a product or symbol is free.

FOXBORO ECKARDT GmbH
Postfach 50 03 47
D-70333 Stuttgart
Tel. # 49(0)711 502-0
Fax # 49(0)711 502-597
<http://www.foxboro-eckardt.com>
<http://www.foxboro.com/instrumentation>

DOKT 534 022 074